

SOUL

Operating Instructions



Table of Contents

1	Legal information.....	8
2	General information.....	9
2.1	Symbols used	9
2.1.1	Display of safety notes	9
2.1.2	Warning signs used.....	9
2.1.3	Instruction signs used.....	10
2.2	Liability	10
2.3	Warranty claims	10
2.4	Spare parts and customer service.....	10
3	Safety.....	12
3.1	Intended use	12
3.2	Foreseeable misuse	12
3.3	Obligations of the operator	13
3.4	Staff requirements	13
3.5	Residual risks.....	13
3.5.1	Risk of electrocution!.....	14
3.5.2	Danger due to cleaning products.....	14
3.5.3	Danger due to allergies.....	15
3.5.4	Danger due to bacteria.....	15
3.5.5	Danger due to heat.....	16
3.5.6	Danger of property damage	17
4	Technical data.....	18
4.1	Types of beverages and output	18
4.2	Machine data	19
4.3	House side power connection	19
4.4	Modem data.....	21
4.5	Water connection values	21
4.6	Ambient conditions.....	22
4.7	Type plate	22
5	Compliance information	24
5.1	Manufacturer address.....	24
5.2	Applied standards	24
6	Product description	26
6.1	Machine overview	26
6.2	Functional lighting.....	27
6.3	Connections and interfaces	28
6.4	Operating elements.....	28
6.4.1	Machine operating elements	29
6.4.2	Operating elements behind the user panel.....	29
6.4.3	Bean hoppers with integrated manual inlet.....	30
6.4.4	User interface.....	30
6.5	Equipment variants installed at the factory.....	31
6.5.1	Schaerer Coffee Soul with 10-inch display.....	31
6.5.2	Schaerer Coffee Soul with 12-inch display.....	32
6.5.3	Best Foam™ fresh milk system.....	32
6.5.4	Automatic height-adjustable beverage outlet (AHA).....	32

6.5.5	Steam wand.....	33
6.5.6	Separate hot water outlet.....	34
6.5.7	Additional water for preparing americanos.....	34
6.5.8	Additional grinders.....	35
6.5.9	Powder system 2000 g (choco or topping).....	35
6.5.10	Mixing cup for powder or topping system.....	35
6.5.11	Twin powder system.....	36
6.5.12	Hot & Cold (cold beverages).....	36
6.5.13	Flavour Point.....	37
6.5.14	Side cooling unit.....	37
6.5.15	Side cooling unit for Centre Milk (CM).....	38
6.5.16	Under-counter cooling unit (UC).....	39
6.5.17	Under-machine cooling unit.....	39
6.5.18	Cup & Cool.....	40
6.6	Retrofitable equipment variants.....	42
6.6.1	Lockable bean hoppers.....	42
6.6.2	Brewing accelerator.....	42
6.6.3	Drip tray with easy access.....	43
6.6.4	Decor elements.....	43
6.6.5	External waste and drinking water tank monitored.....	44
6.6.6	Under-counter grounds disposal.....	44
6.6.7	Machine feet.....	45
6.6.8	Cup positioning aid.....	45
6.6.9	Schaerer Coffee Link (data exchange).....	45
6.6.10	Payment systems.....	46
6.6.11	Cup warmer.....	46
6.6.12	ProCare overview.....	47
7	Transport.....	49
7.1	Scope of delivery of accessories.....	49
7.2	Conditions for transport.....	50
8	Installation and commissioning.....	52
8.1	Unpacking.....	53
8.1.1	Unpacking machine.....	53
8.1.2	Unpacking accessories.....	53
8.2	Setup.....	53
8.3	Installation requirements.....	54
8.4	Connecting power.....	55
8.5	Connecting water.....	56
8.5.1	Variant with external drinking and waste water tank.....	57
8.6	Assemble drip tray.....	57
8.7	Connecting milk system.....	58
8.8	Connecting ProCare unit.....	59
8.8.1	Connecting ProCare unit to machine.....	59
8.8.2	Connecting ProCare unit to cooling unit.....	60
8.8.3	Connecting ProCare unit cable.....	61
8.9	Installing optional accessories.....	61
8.9.1	Connecting optional accessories to power supply.....	61
8.9.2	Establishing communication connection (CAN bus).....	62
8.9.3	Connecting the Flavour Point 4-way UC (syrup module).....	63
8.10	Screen-guided commissioning.....	64
9	Operation.....	65
9.1	Recurring additional tasks.....	65
9.1.1	Filling bean hopper.....	65
9.1.2	Filling powder container.....	66
9.1.3	Refilling water.....	67
9.1.4	Filling BestFoam™ milk system.....	68

9.1.5	Filling the Flavour Point or changing bottles	69
9.1.6	Opening and closing the operating unit.....	70
9.1.7	Removing bean hoppers and powder containers	71
9.1.8	Inserting or changing ProCare cleaning bag.....	72
9.2	Enable.....	75
9.2.1	Check before switching on.....	75
9.2.2	Switching on machine	76
9.2.3	Switching on Flavour Point	76
9.2.4	Switching on optional accessories.....	77
9.2.5	Setting cooling unit temperature.....	78
9.3	Positioning beverage outlet	79
9.4	Operating modes	79
9.4.1	Functions of the operating modes	79
9.4.2	Guest mode	80
9.4.3	Staff mode	81
9.4.4	Frequent user mode	83
9.5	Beverage supply	85
9.5.1	Selecting beverage.....	85
9.5.2	Modifying beverage	87
9.5.3	Double beverage pre-selection	89
9.5.4	Dispensing pre-selected beverages multiple times	90
9.5.5	Decaffeinated coffee pre-selection	91
9.5.6	Barista preselection.....	92
9.5.7	Positioning cup/mug	92
9.5.8	Paying for beverage	93
9.5.9	Dispensing beverage.....	94
9.5.10	Progress display for beverage dispensing	94
9.5.11	Completion of beverage	95
9.5.12	Canceling beverage dispensing	96
9.6	Dispensing steam	97
9.7	Using manual inlet	98
9.8	Generic functions of the user interface	98
9.8.1	Navigation in the interface.....	99
9.8.2	Display of beverages	99
9.8.3	Pending error message or instruction for action.....	100
9.8.4	Error messages (simple)	101
9.8.5	Error messages (specific)	101
9.9	Service menu.....	101
9.9.1	Service menu button	102
9.9.2	Service menu overview	102
9.9.3	Quick info.....	103
9.9.4	Logging into a profile	104
9.9.5	Functions in the Service menu	105
9.10	Emptying.....	111
9.10.1	Emptying grounds container.....	111
9.10.2	Emptying external waste water tank	112
9.11	Switching off	112
9.11.1	Switching machine to standby	113
9.11.2	Longer downtimes (from 1 week)	114
9.11.3	Switching off optional accessories	114
10	Cleaning	116
10.1	Cleaning regulations and conditions	116
10.2	Cleaning products	117
10.3	Cleaning stages.....	118
10.4	Cleaning intervals	120
10.5	Machine rinsing.....	121
10.5.1	Automatic switch-on/switch-off rinsing.....	121

10.5.2	Configured rinsings.....	121
10.5.3	Manual rinsing (Service menu).....	122
10.6	Display-guided cleaning.....	122
10.6.1	Display-guided cleaning types.....	122
10.6.2	Required utensils.....	123
10.6.3	Calling up cleaning variants.....	123
10.6.4	Starting scheduled cleaning (without ProCare).....	124
10.6.5	Starting scheduled cleaning (with ProCare).....	132
10.6.6	Additional cleaning.....	139
10.6.7	ProCare: Cleaning milk hose piece (Plug & Clean).....	140
10.6.8	Display-guided cleaning: Flavour Point.....	142
10.7	Cleaning schedule.....	146
10.7.1	Calling up cleaning schedule.....	146
10.7.2	Setting cleaning times.....	147
10.8	Manual cleaning.....	149
10.8.1	Manual grounds container.....	150
10.8.2	Cleaning brewing chamber.....	151
10.8.3	Cleaning drip tray and drip grid.....	151
10.8.4	Cleaning milk container.....	152
10.8.5	Cleaning cooling unit.....	153
10.8.6	Defrosting cooling unit.....	154
10.8.7	Clean touch screen.....	154
10.8.8	Cleaning the steam wand.....	155
10.8.9	Cleaning external drinking water tank.....	158
10.8.10	Cleaning external waste water tank.....	159
10.8.11	Cleaning additional devices.....	160
10.8.12	Cleaning bean hoppers.....	160
10.8.13	Cleaning powder container.....	162
10.8.14	Cleaning the lower part of the beverage outlet.....	171
10.8.15	Clean outer surfaces.....	172
11	Maintenance.....	174
11.1	Maintenance intervals.....	175
11.2	Performing maintenance and resetting counter.....	175
11.3	Replacing external water filter.....	177
12	Descaling.....	178
12.1	Required descaling material.....	178
12.2	Uptime! descaling cartridge.....	179
12.3	Checking waste water drainage.....	179
12.4	“Descaling” screen.....	180
12.5	Performing descaling with descaling cartridge.....	180
12.6	Disposing of descaling cartridge.....	187
12.7	Descaling with ProCare.....	187
13	Advanced settings.....	190
13.1	User interface elements.....	190
13.2	USB interface.....	192
13.3	Profiles and authorizations.....	192
13.3.1	Overview of profile authorizations.....	193
13.3.2	Caretaker profile.....	193
13.3.3	Bookkeeper profile.....	194
13.3.4	Chef de service profile.....	194
13.3.5	Quality manager profile.....	195
13.3.6	Machine Operator profile.....	195
13.4	Configuring machine.....	196
13.4.1	Configuring system.....	196

13.4.2	Configuring software.....	201
13.4.3	Configuring service settings	203
13.4.4	Calling up information	214
13.4.5	Saving changes and loading them into the machine.....	220
14	Troubleshooting.....	221
14.1	Type of fault display.....	221
14.2	Meaning of the functional lighting	221
14.3	Notifications on the display.....	221
14.4	Faults with display messages	223
14.4.1	“Fault” display message	223
14.4.2	“Error” display message.....	226
14.4.3	“Instruction” display message.....	228
14.4.4	“Note” display message.....	229
14.5	Malfunctions without display messages.....	229
15	Disassembly.....	232
16	Disposal.....	233
	List of figures	234

1 Legal information

Publisher

Schaerer AG, Niedermattstrasse 3b, 4528 Zuchwil, Switzerland

Concept and editing

Schaerer AG, Niedermattstrasse 3b, 4528 Zuchwil, Switzerland

Copyright®

Schaerer AG, Niedermattstrasse 3b, 4528 Zuchwil, Switzerland

This document is protected by copyright. All rights reserved. Reproduction, distribution, transmission by electronic systems or translation into other languages is not permitted without the written consent of the manufacturer. This applies to the entire document as well as to individual sections thereof.

The content of this document is based on the most current data available at the time of printing. The manufacturer reserves the right to make changes at any time without prior notice.

All figures, illustrations and display notifications in this manual are examples only. Due to the wide range of options, the machine may differ from the devices shown here.

The manufacturer is liable solely for the contents of the original document.

2 General information

This technical documentation contains important instructions for handling the machine. The technical documentation is an integral part of the product and must be kept in the immediate vicinity of the machine and accessible to staff at all times. Read the technical documentation carefully before working with the machine!

Some of the illustrations in these instructions have been simplified for purposes of clearer presentation. The simplified illustrations may differ slightly from the scale and design of your original machine.

2.1 Symbols used

This chapter contains information on the display of safety notes in this document.

2.1.1 Display of safety notes



DANGER

Immediately dangerous situation that could result in death or serious injury.

The measures described for preventing this danger must be strictly observed.



WARNING

Generally dangerous situation that could result in serious injury.

The measures described for preventing this danger must be strictly observed.



CAUTION

Generally dangerous situation that could result in minor injury.

The measures described for preventing this danger must be strictly observed.



NOTE

There is a situation that could result in property damage.



The measures described for preventing this danger must be strictly observed.

2.1.2 Warning signs used

Symbols for dangers and instructions can appear both in the operating instructions and on the machine.

Icon	Type of danger	Icon	Type of danger
	Warning of hot fluids		Warning of hot surface
	Warning of hot steam		Warning of dangerous electrical voltage
	Warning of poisonous substances		Warning of hand injuries

2.1.3 Instruction signs used

Icon	Meaning	Icon	Meaning
	Read documentation!		Wear safety gloves!
	Wear safety goggles!		Wash hands!
	Pull out power plug!		

2.2 Liability

The manufacturer accepts no liability for damage caused by:

- Non-compliance with the operating instructions
- Non-intended use or misuse
- Use by unqualified staff
- Unauthorized modifications
- Technical modifications
- Use of non-approved spare parts

The obligations agreed upon in the delivery contract, the General Terms and Conditions and the statutory regulations valid at the time of contract conclusion apply.

2.3 Warranty claims

If the information in the technical documentation is not observed, warranty claims can become invalid.

No liability is accepted:

- For parts which are subject to natural wear. This includes the milk container, the milk-carrying parts (if a milk system is present), seals, mixer, brewing unit and the surfaces of the stainless steel bases.
- For defects as a result of climatic influences, chemical, physical, electrochemical or electrical influences.
- If a descaling system is not used and defects occur even though the local water hardness necessitates the use of a descaling system.
- For defects caused by non-compliance with the regulations on transport, installation and commissioning, operation, cleaning and maintenance of the machine / device (e.g. operating instructions and maintenance instructions).
- For defects caused by the use of non-manufacturer spare parts or by faulty or negligent assembly or handling by the operator or third parties.
- For defects caused by improper modifications or repair work carried out by the operator or third parties without the consent of the manufacturer.
- For defects arising from inappropriate or improper use.

2.4 Spare parts and customer service

Information on accessories and spare parts can be found in the spare parts catalog in the **Schaerer Coffee Link**.

For service requests and technical support, please contact the service partner in your country.

You can find a list of all responsible service partners worldwide at www.schaerer.com.

Schaerer Service can be reached via a central address if the service center for a particular location is not known.

Schaerer AG

Niedermattstrasse 3b

4528 Zuchwil

Switzerland

Service center

Phone: +41 32 681 62 00

E-Mail: info@schaerer.com

3 Safety

Safety when handling the electrical device is of the utmost importance. This chapter contains all the information essential for ensuring safe handling and preventing injury to persons and damage to property.

3.1 Intended use

The machine is designed to dispense coffee beverages, hot water, milk beverages, powder beverages (toppings & chocolate) and flavors (syrup) in various versions and combinations in cups, mugs or glasses.

The bean hopper may only be filled with coffee beans, the powder container only with choco powder, the milk container only with milk and the manual inlet only with ground coffee.

The machine is intended for commercial use in hotels, restaurants or similar places. The machine may be installed in self-service locations and be operated without supervision.

The machine may be used in stores, offices or similar working environments, hotels, motels and bed and breakfasts and may be operated by non-professionals or customers.

Use for this purpose is subject to these operating instructions. Any other use or use beyond this is considered improper use. The manufacturer does not assume liability for any resulting damage.

The machine can be used by children from 8 years of age and above and persons with reduced physical, sensory or mental capabilities or lack of experience and knowledge if they are supervised or have been given instruction concerning use of the machine in a safe way and understand the risks involved. Children must not be allowed to play with the machine. Cleaning and user maintenance must not be performed by children without supervision. Cleaning and user maintenance may only be performed by persons who have the knowledge and practical experience with the device, particularly with regard to safety and hygiene.

Use is also subject to the **General Terms and Conditions** of the manufacturer. Any other use or use beyond this is considered improper use. The manufacturer does not assume liability for any resulting damage.

3.2 Foreseeable misuse

Any use of the machine that goes beyond the intended use or any other use is considered misuse and can lead to hazardous situations. Improper handling of the machine can lead to injuries.

- ☞ Read the operating instructions carefully before use.
- ☞ Only allow qualified service staff access to the service area of the machine and optional accessories.
- ☞ Only have cleaning and user maintenance done by persons who have the knowledge and practical experience with the machine, particularly with regard to safety and hygiene.
- ☞ Have trained persons supervise the machine in self-service mode and in regular operation so that they are available to answer questions from the user and ensure compliance with the cleaning and maintenance measures.
- ☞ Only use sufficiently cooled milk.
- ☞ Only use the optional steam wand to foam milk.
- ☞ Never modify safety equipment of the machine.
- ☞ Only use the machine when it is functioning perfectly and is not damaged.
- ☞ Only fill the bean hoppers with coffee beans.
- ☞ Only fill the powder container with automatic coffee machine powder.
- ☞ Only fill the milk container with milk or milk substitute products.
- ☞ Only ground coffee should be poured into the manual inlet, with the exception of a cleaning tablet during cleaning.

3.3 Obligations of the operator

The operator must ensure regular maintenance and inspection of the safety equipment by a service partner of the manufacturer, its representative or other authorized persons. Material defects must be reported to the manufacturer in writing within 30 days. For hidden defects, the deadline is 12 months from the time of installation (work report, handover protocol), but no longer than 18 months after leaving the factory.

Damaged or defective safety-related parts such as safety valves, safety thermostats, boilers, etc. must be replaced and may not under any circumstances be repaired.

The operator is responsible for complying with the maintenance instructions.

3.4 Staff requirements



WARNING

Risk of injury due to insufficient qualification!

Improper handling can lead to considerable personal injury and property damage.

All work may only be carried out by qualified staff.

Only persons who can be expected to carry out their work reliably are permitted as staff. Persons whose ability to react is impaired, for instance by drugs, alcohol or medication, are not allowed to work on the machine.

When selecting staff, the age and occupation-specific regulations applicable at the place of use must be observed.

The following qualifications are specified in the operating instructions for various areas of activity:

Instructed person

Has been instructed by the operator about the assigned tasks and the possible dangers of improper behavior.

Specialist staff

Is able to carry out the work assigned to him/her and independently identify and avoid possible dangers based on his/her professional training, knowledge and experience as well as knowledge of the relevant regulations.

Service staff

Is a qualified specialist trained by the manufacturer or the operator specifically for service tasks.

Qualified electrician

Is able to carry out work on electrical equipment and independently identify and avoid possible dangers based on his/her professional training, knowledge and experience as well as knowledge of the relevant regulations. The qualified electrician is trained for the specific location where he/she is working and knows the relevant standards and regulations.

3.5 Residual risks

Maximum safety is one of the most important product features for the manufacturer. The effectiveness of the safety equipment is only guaranteed if the following chapter on preventing of injuries and health hazards is observed.



These safety notes can be requested from the manufacturer or downloaded directly from the website or the Media Pool.

3.5.1 Risk of electrocution!



DANGER

Danger to life from electrocution!



Improper handling of electrical devices can result in electrocution. There is danger to life.

- Only have work on electrical equipment carried out by a qualified electrician.
- Connect the device to a fused circuit.
- Route the connection through a ground fault circuit interrupter.
- Observe the relevant guidelines on low voltage and/or the national or local safety regulations and directives.
- Earth the connection in accordance with regulations and secure it against electric shock.
- Make sure that the supply voltage matches the specifications on the serial plate of the device.
- Never touch live parts.
- Always switch off the main switch or disconnect the device from the power supply before carrying out maintenance work.
- Make sure that the device can be disconnected from the power supply with all poles. Disconnected connections must be visible at all times from the location of the device and the disconnection must be secured by a locking mechanism.
- Only have connection cables replaced by qualified service staff.

3.5.2 Danger due to cleaning products

Read the information on the packaging of the cleaning product carefully before using it. If not available, the safety data sheet can be requested from the sales partner (see cleaning product packaging).



WARNING

Risk of poisoning from cleaning products!



There is a risk of poisoning if cleaning products are ingested.



Only use cleaning products recommended by the manufacturer.



Read the information on the packaging and the safety data sheet carefully before using the cleaning product. If no safety data sheet is available, request one from the sales partner.



Keep cleaning products away from children and unauthorized persons.

Do not touch the cleaning products with your bare hands and do not ingest them.



Never mix cleaning products with other chemicals.

Only use cleaning and descaling products for their intended purpose (see label).

Do not eat or drink while using cleaning products.

Ensure good ventilation when using cleaning products.

Wear protective gloves and protective goggles when using cleaning products.

Wash your hands thoroughly immediately after using cleaning products.

Emergency information

Ask the cleaning product manufacturer (see cleaning product label) for the telephone number of the emergency information center of the Toxicological Information Center.

If your country does not have such an institution, contact the following office:

Swiss Toxicological Information Center

Calls from abroad

+4144 251 51 51

Swiss Toxicological Information Center

Calls from Switzerland

145

Internet

www.toxinfo.ch

3.5.3 Danger due to allergies



⚠ CAUTION

Health risk due to additives!

Beverages with additives or residues can trigger allergies.

- ☞ In self-service mode: Observe the information plate attached to the machine. The information plate contains information about any additives that cause allergies.
- ☞ In user mode: Inform staff that any additives used may cause allergies.

3.5.4 Danger due to bacteria



⚠ CAUTION

Health problems due to contaminated water!

Improper handling of water can lead to health problems.

- ☞ Make sure that the water is free of dirt and bacteria.
- ☞ Do not connect the machine to pure osmosis or other aggressive types of water.
- ☞ Make sure that the carbonate hardness is between 4 and 6 °dKH or 8 and 12 °fKH.
- ☞ Make sure that the total hardness is higher than the carbonate hardness.
- ☞ Do not exceed the maximum chlorine content of 50 mg per liter.
- ☞ Make sure that the pH value is between 6.5 and 7 (pH neutral).
- ☞ Machines with drinking water tank (internal and external): Fill the drinking water tank with fresh water every day and rinse it thoroughly before filling.



⚠ CAUTION

Health problems due to contaminated coffee!

Improper handling of coffee can lead to health problems.

- ☞ Check the packaging for damage before opening.
- ☞ Do not fill with more coffee beans than are needed in one day.
- ☞ Close the bean hopper lid immediately after filling.
- ☞ Store coffee in a dry, cold and dark place.
- ☞ Store coffee separately from cleaning products.
- ☞ Use the oldest products first ("first in – first out").
- ☞ Use coffee before the expiration date is exceeded.
- ☞ Always close opened packages tightly so that the contents remain fresh and are protected from contamination.

**CAUTION****Health problems due to contaminated/unsuitable milk!**

Improper handling of milk can lead to health problems.

- ☞ Do not use raw milk.
- ☞ Only use pasteurized milk or milk that has been heated using a UHT process.
- ☞ Only use homogenized milk.
- ☞ Used pre-cooled milk with a temperature between 3 °C (37.4 °F) and 5 °C (41 °F).
- ☞ Use milk straight from the original package.
- ☞ Check the packaging for damage before opening.
- ☞ Use the oldest products first ("first in – first out").
- ☞ Wear protective gloves when working with milk.
- ☞ Always close opened packages tightly so that the contents remain fresh and are protected from contamination.
- ☞ Use milk before the expiration date is exceeded.
- ☞ Store milk in a dry and dark location with a maximum temperature of 7 °C (44.6 °F).
- ☞ Store milk separately from cleaning products.
- ☞ For machines with internal milk system and cooling unit: Do not fill with more milk than is needed in one day.
- ☞ Never refill milk. Always clean the container thoroughly before filling.
- ☞ Close the milk container cover and cooling unit (internal and external) immediately after filling.

**CAUTION****Health problems due to contaminated automatic coffee machine powder!**

Improper handling of automatic coffee machine powder can lead to health problems.

- ☞ Check the packaging for damage before opening.
- ☞ Do not fill with more automatic coffee machine powder than is needed in one day.
- ☞ Close the powder container cover immediately after filling.
- ☞ Store automatic coffee machine powder in a dry, cold and dark place.
- ☞ Store automatic coffee machine powder separately from cleaning products.
- ☞ Use the oldest products first ("first in – first out").
- ☞ Use automatic coffee machine powder before the expiration date is exceeded.
- ☞ Always close opened packages tightly so that the contents remain fresh and are protected from contamination.

3.5.5 Danger due to heat

**CAUTION****Risk of scalding due to hot fluid!**

There is a risk of scalding in the dispensing area for beverages, hot water and steam.

- ☞ Never reach under the dispensing points during dispensing or cleaning.
- ☞ Always lock the control unit before cleaning to prevent accidental input.

**CAUTION****Hot surface!**

The dispensing points and the brewing unit can be hot.

- ☞ Never touch hot machine parts.
- ☞ Only touch the beverage outlet at the designated places.
- ☞ Only remove the brewing unit when the machine has cooled down.

3.5.6 Danger of property damage

**NOTE****Property damage due to improper handling of the machine!**

Improper handling of the machine can lead to property damage or contamination.

- ☞ If the water has a carbonate hardness of more than 6 °dKH, install a descaling system. Damage may otherwise occur due to limescale.
- ☞ After long periods of standstill (e.g. company vacations), clean the machine before using it again.
- ☞ Protect the machine from the effects of the weather (frost, moisture, etc.).
- ☞ In the event of malfunctions, observe the information in the operating instructions and call in a qualified service technician if necessary.
- ☞ Only use original spare parts.
- ☞ Immediately report externally visible damage and leaks to the service partner and have the affected parts replaced or repaired.
- ☞ Do not spray the machine with water or clean it with a steam cleaner.
- ☞ Do not place the machine on a surface where it could be exposed to water jets.
- ☞ Do not use caramelized coffee.
- ☞ Fill the hoppers only with the intended products.
- ☞ Never use freeze-dried coffee. This will clog the brewing unit.
- ☞ If the machine and/or optional accessories are transported at temperatures below 10 °C, store the machine and/or optional accessories at room temperature for three hours before connecting the machine and/or optional accessories to the power supply and switching them on. Otherwise there is a risk of short circuits or damage to electrical components due to condensation.
- ☞ Always use the new hose set supplied with the machine (drinking/waste water hose). Never use old hose sets.

4 Technical data

This chapter contains detailed information on the technical specifications and provides an overview of the most important features, for instance performance and connection values.

4.1 Types of beverages and output

Depending on the machine variant and options, the following beverages can be prepared:

Max. beverage output per hour

Espresso 50 – 60 ml	Approx. 180 cups
Coffee 120 ml	Approx. 180 cups

Recommended daily output

Espresso 50 – 60 ml	Approx. 250 cups
Coffee 120 ml	Approx. 250 cups

Available beverages	Standard	Option
Espresso	x	
Coffee	x	
Coffee/Café crème	x	
Mug (250 ml) ^{AW}		x
Pot (500 ml) ^{AW}		x
Americano ^{AC, AW}		x
White americano ^{** , ** , AC, AW}		x
Latte (light/dark) ^{* , **}		x
Cappuccino ^{* , **}		x
Latte macchiato ^{* , **}		x
Espresso macchiato ^{* , **}		x
Chociatto ^{***}		x
Hot chocolate ^{***}		x
Flat white [*]		x
Hot milk [*]		x
Hot milk foam [*]		x
Cold milk [*]		x
Cold milk foam ^{* , **}		x
Best Foam™ milk foam [*]		x
Hot water/External hot water	x	x
Steam		x
Powder beverages/Instant beverages		
Liquor/Coffee		x

Recommended machine equipment:

* With fresh milk

** With fresh milk and/or topping (milk powder)

*** With choco

AC Brewing accelerator

AW Additional water

4.2 Machine data

Boiler nominal power*	Steam boiler	Hot water boiler
	3000 W	3000 W

* See type plate for special equipment. The specified values correspond to the standard equipment.

Operating temperature	Steam boiler	Hot water boiler
Minimum operating temperature (T min.)	10 °C (50 °F)	10 °C (50 °F)
Operating temperature	127 °C (261 °F)	95 °C (203 °F)

Overpressure	Steam boiler	Hot water boiler
Working pressure	0.25 MPa (36.26 psi)	0.8 MPa (116.03 psi)
Permissible operating overpressure (p max.)	0.5 MPa (72.52 psi)	1.2 MPa (174.04 psi)
Test overpressure	2.4 MPa (348.09 psi)	2.4 MPa (348.09 psi)

Capacities	
Drinking water capacity	Mains water supply
Coffee bean hopper capacity	Standard bean hopper 1200 g Retrofittable equipment variants <ul style="list-style-type: none"> ▪ Extended bean hopper 2000 g ▪ Shortened bean hopper 700 g
Grounds container capacity	60 – 70 coffee cakes

External dimensions	
Machine width	330 mm (12.99")
Width with side cooling unit	723 mm (28.46")
Height including bean hopper and key	761 mm (29.96")
Depth	600 mm (23.62")

Weight	
Empty weight	Approx. 55 kg (121 lbs)*

Noise level	
Continuous sound pressure level	< 70 dB(A)*

* The A-weighted sound pressure level (slow) and Lpa (pulses) at the workplace of the operator is below 70 dB(A) in every operating mode.

4.3 House side power connection

The machine can be operated both on a 50 Hz mains and on a 60 Hz mains.

Power supply	Connection values	Fuse protection at the building	Connecting cable, conductor cross-section
1L, N, PE	220 – 240 V	10 – 13 A	3 x 1 mm ²

Power supply	Connection values	Fuse protection at the building	Connecting cable, conductor cross-section
	50/60 Hz 2000 – 2400 W ¹		3 x 17 AWG
1L, N, PE	220 – 240 V 50/60 Hz 3000 – 3600 W ²	16 – 30 A	3 x 1.5 mm ² 3 x 15 AWG
1L, N, PE	220 – 240 V 50/60 Hz 6000 – 7000 W ³	30 A	3 x 4 mm ² 3 x 11 AWG
2L, PE	200V 60 Hz 2000 W ¹	10 – 30 A	3 x 1 mm ² 3 x 17 AWG
2L, PE	200V 60 Hz 3000 W ²	16 – 30 A	3 x 1.5 mm ² 3 x 15 AWG
2L, PE	200V 60 Hz 6000 W ³	30 A	3 x 4 mm ² 3 x 11 AWG
2L, PE	208 – 240 V 60 Hz 1900 – 2400 W ¹	10 – 30 A	3 x 1 mm ² 3 x 17 AWG
2L, PE	208 – 240 V 60 Hz 2800 – 3600 W ²	15 – 30 A	3 x 1.5 mm ² 3 x 15 AWG
2L, PE	208 – 240 V 60 Hz 5100 – 7000 W ³	30 A	3 x 4 mm ² 3 x 11 AWG
2L, PE	200V 50/60 Hz 1800 W ¹	15 – 25 A	3 x 2 mm ² 3 x 14 AWG
2L, PE	200V 50/60 Hz 2600 W ²	15 – 25 A	3 x 2 mm ² 3 x 14 AWG
3L, PE	200V 60 Hz 5700 – 8700 W ⁴	25 – 30 A	4 x 2.5 mm ² 3 x 13 AWG
3L, PE	208 – 240 V 60 Hz 5100 – 6400 W ³	25 – 30 A	4 x 2.5 mm ² 3 x 13 AWG
3L, PE	208 – 240 V 60 Hz 7700 – 10300 W ⁴	25 – 30 A	4 x 2.5 mm ² 3 x 13 AWG
3L, PE	200V 50/60 Hz 4700 W ³	25 A	4 x 2.5 mm ² 3 x 13 AWG

Power supply	Connection values	Fuse protection at the building	Connecting cable, conductor cross-section
3L, PE	200V 50/60 Hz 6900 W ⁴	25 A	4 x 2.5 mm ² 3 x 13 AWG
3L, N, PE	380 – 415 V 50/60 Hz 5700 – 6400 W ³	16 – 30 A	5 x 1.5 mm ² 3 x 15 AWG
3L, N, PE	380 – 415 V 50/60 Hz 8700 – 10300 W ⁴	16 – 30 A	5 x 1.5 mm ² 3 x 15 AWG

¹ Equipment 1 or 2 boiler with 2 kW (serial heating)

² Equipment 1 or 2 boiler with 3 kW (serial heating)

³ Equipment 2 boiler with 3 kW (simultaneous heating)

⁴ Equipment 3 boiler with 3 kW (simultaneous heating)

4.4 Modem data

The machine can be equipped with a modem for WLAN and WWAN.

Radio standard	Frequency bands	Max. transmitting power
LTE FDD	B1, B3, B5, B7, B8, B20	23 dBm +/- 2 dBm
WCDMA	B1, B5, B8	24 dBm +/- 3 dBm
GSM	B3, B8	33 dBm +/- 2 dBm

WWAN (mobile communications) is switched on when the machine is delivered.

Radio standard	Frequency bands	Max. transmitting power
WLAN	2.4 GHz	20 dBm

WLAN is switched off when the machine is delivered.

WLAN is not supported by the machine. A WLAN connection is not possible.

4.5 Water connection values

Pressure and temperature	
Water pressure	Minimum 0.2 MPa (29.07 psi) Maximum 1.0 MPa (145 psi)
Flow rate	Minimum 2 l/min
Water input temperature	Minimum 10 °C (50 °F) Maximum 30 °C (86 °F)
Water quality	
Maximum chlorine content	Observe the local regulations on the maximum permitted chlorine content.
pH value	Minimum 6.5 Maximum 7

Water quality	
Carbonate hardness (German)	Minimum 4 °dKH Maximum 6 °dKH (If the carbonate hardness is higher, a descaling system must be installed upstream.)
Carbonate hardness (French)	Minimum 8 °fKH Maximum 12 °fKH
Total hardness	> Carbonate hardness

4.6 Ambient conditions

The following climatic conditions apply to the location:

Ambient temperature	
Minimum	+10 °C (50 °F)
Maximum	+40 °C (104 °F)

Relative humidity	
Maximum	80% RH

Height above sea level	
Maximum	2500 m (8202 ft)

The machine or device is designed exclusively for indoor use. The machine or device must not be used outdoors and must never be exposed to weather conditions (rain, snow, frost).

4.7 Type plate

Type designation	Model
SOUL 10 (SOUL)	No model variant
SOUL 12 (SOUL)	No model variant

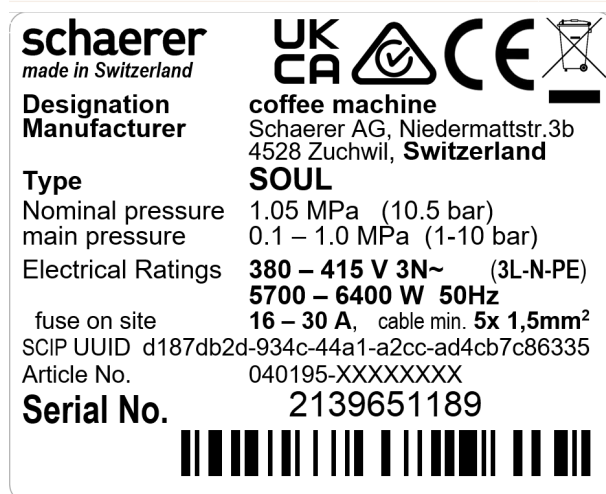

Fig. 1: Type plate

The serial plate is located on the front of the machine behind the cover on the right.

- ▮ To read the data from the serial plate:
- ☞ Pull the grounds drawer out of the machine.

- ☞ Open the cover on the right of the grounds drawer.
- ☞ In the event of a fault or warranty claim, report the following data from the type plate:
 - Machine or device type
 - Nominal power
 - Nominal voltage
 - Fuse value on site
 - Serial number



An additional type plate is located on the rear behind the lower cover plate.

5 Compliance information

This chapter contains information on the conformity of the electrical device with applicable standards, directives and regulations.

5.1 Manufacturer address

Manufacturer	Documentation manager
Schaerer AG	Schaerer AG
Niedermattstrasse 3b	Director of R&D GBU PCM
4528 Zuchwil	Niedermattstrasse 3b
Switzerland	4528 Zuchwil
+41 32 681 62 00	Switzerland
info@schaerer.com	
www.schaerer.com	

5.2 Applied standards

The manufacturer declares herewith that this machine or device complies with all relevant stipulations of the specified directives. This declaration loses its validity if changes are made to the devices that have not been arranged with us. The following harmonized standards have been applied. A DNV GL – **Business Assurance** quality management system is used for proper implementation of the requirements and is certified in accordance with ISO 9001:2015, ISO 14001:2015 and ISO 45001:2018. The manufacturer assumes sole responsibility for issuing this declaration of conformity.

The object of the declaration described above fulfills the provisions of Directive 2011/65/EC of the European Parliament and of the Council of June 8, 2011 on the restriction of the use of certain hazardous substances in electrical and electronic equipment.

For CE conformity	
MD 2006/42/EC	EMC Directive 2014/30/EU
<ul style="list-style-type: none"> ▪ EN 60335-1:2020-08 +A11 +AC ▪ EN 60335-2-75:2010-11 +A1 +A11 +A12 +A2 ▪ EN 62233:2008 	<ul style="list-style-type: none"> ▪ EN 55014-1:2018-08 +A1 +A2 ▪ EN 55014-2:2016-01 +A1 +A2 +AC ▪ EN 55014-2:2016-01 +A1 +A2 +AC ▪ EN 61000-3-11:2021-03
RoHS Directive 2011/65/EU	RED 2014/53/EU
<ul style="list-style-type: none"> ▪ EN IEC 63000:2019-05 	<ul style="list-style-type: none"> ▪ EN 301 489-1 V2.1.1:2017 ▪ EN 301 489-7 V1.3.1:2005 ▪ EN 301 489-24 V1.5.1:2010

An original Declaration of Conformity is included in the packaging. The machine or device has the CE label.

For compliance with European directives and regulations	
WEEE Directive 2012/19/EU	POP Regulation 2019/1021
For the EU Chemicals Regulation	
REACH Regulation 1907/2006/EC	

International (CB)

Safety	<ul style="list-style-type: none"> ▪ IEC 60335-1:2020-08 ▪ IEC 60335-2-75 ▪ BS EN 62233:2008
EMC	<ul style="list-style-type: none"> ▪ CISPR 14-1 ▪ CISPR 14-2 ▪ IEC 61000-3-2 ▪ IEC 61000-3-11

CB	Scheme > International system of mutual recognition of test reports and certificates
CE	Requirements of harmonization legislation of the European Community
CISPR	International Special Committee on Radio Interference
EC/EU	The European Community is a part of the European Union consisting of EC/CFSP/AFSJ
EMC	Electromagnetic compatibility
IEC	International conformity assessment system for electrotechnical equipment and components
MD	Machinery Directive (European Parliament and Council)
POP	Regulation (EU) on persistent organic pollutants
REACH	EU Chemicals Regulation for the Registration, Evaluation, Authorization and Restriction of Chemicals
RED	European approval directive for radio equipment and receivers (radio communication)
RoHS	Restriction of hazardous substances
WEEE	Waste of Electrical and Electronic Equipment

6 Product description

This chapter provides an overview of the most important components, features, functions and equipment variants. Knowledge of the product functionality is essential for safe and optimal operation.

6.1 Machine overview

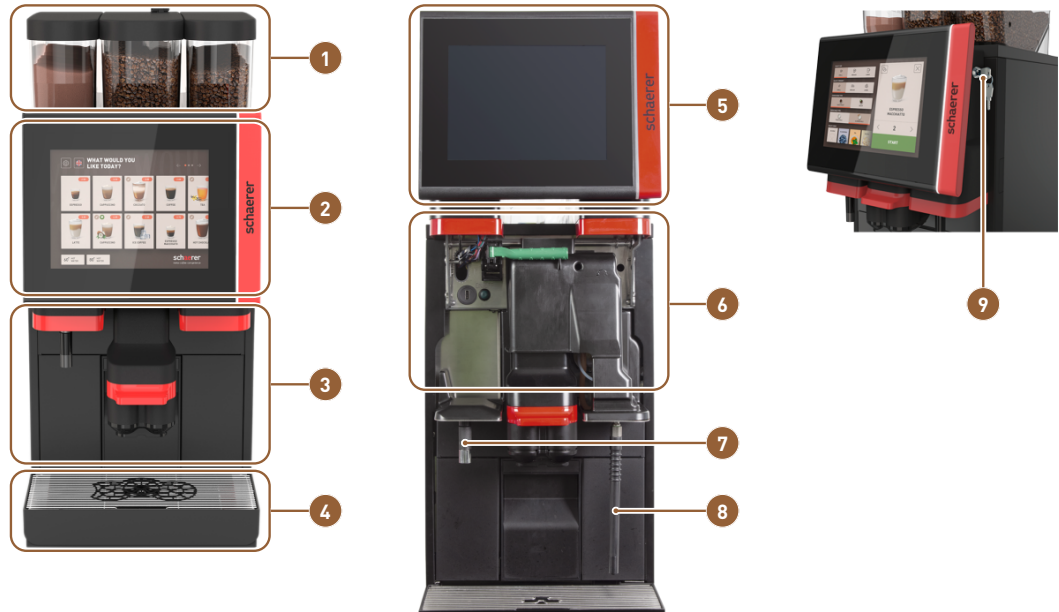

Fig. 2: Machine overview

1 Bean hoppers and powder container (type and number depends on configuration)	2 User panel with 10"/12" touch screen
3 Dispensing area with beverage outlet and optional hot water/steam outlet	4 Machine drip tray with cup positioning aid
5 User panel turned upwards	6 Area with inner operating elements
7 Separate hot water outlet (equipment variant)	8 Steam wand (equipment variant)
9 Closing device for control panel	

6.2 Functional lighting



Fig. 3: Functional lighting

1 Lighting right of display (10" display and 12" display)

2 Lighting on left machine side (12" display only, optional)

The functional lighting provides information about the operating condition of the machine. The color of the functional lighting can be adjusted.

Color	Meaning
White	The machine is ready for use.
Yellow	Action is required soon (refill, clean).
Red	A machine error (grinder blocked, water flow error) has occurred.

The functional lighting on the left side of the SOUL machine with a 12-inch display is an optional equipment variant installed at the factory.

6.3 Connections and interfaces

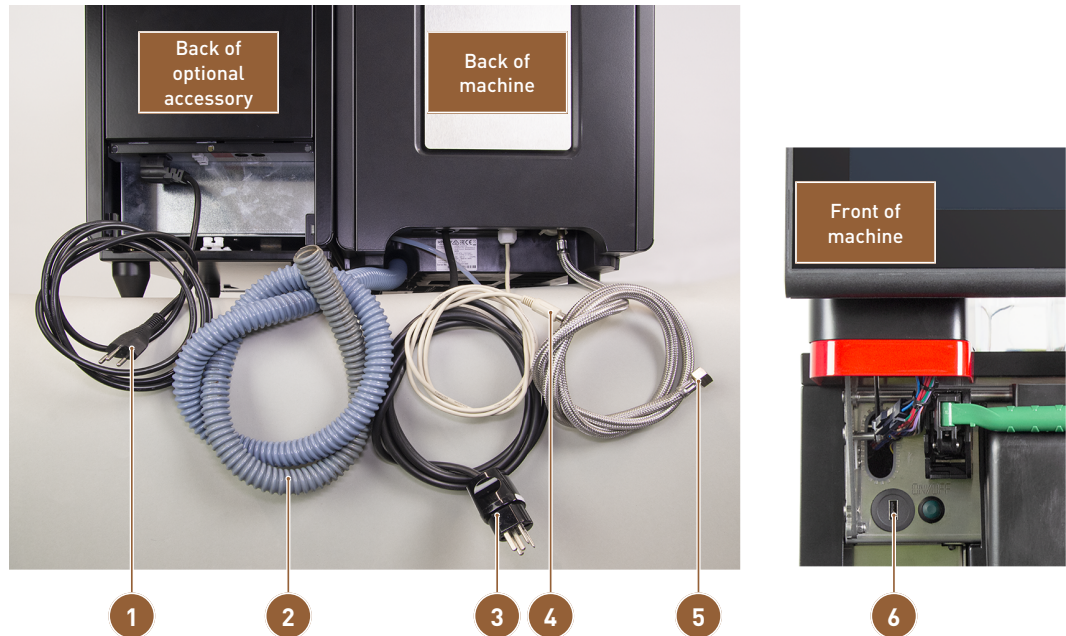

Fig. 4: Connections of coffee machine and additional unit

- | | |
|---|--|
| <p>1 Power cable with cold device plug and country-specific power plug for optional accessory</p> <p>3 Power cable with plug or fixed connection with main switch; the plug may vary depending on the country. The serial plate provides information on the required maximum fuse protection and the required minimum conductor cross-section.</p> <p>5 Mains water supply 3/8" or connection to the optional external drinking water tank</p> | <p>2 Waste water outlet hose \varnothing 20 mm for siphon or external waste water tank; the hose may vary depending on the country.</p> <p>4 Interface cable for communication between the coffee machine and optional accessories</p> <p>6 USB port and communication interface</p> |
|---|--|

6.4 Operating elements

This chapter provides an overview of the functions of the operating elements and the user interface. Knowledge of the operating elements is required for daily operation of the machine.

6.4.1 Machine operating elements



Fig. 5: Overview of external operating elements

- | | |
|--|---|
| <ul style="list-style-type: none"> 1 Manual inlet for ground coffee, cleaning tab 3 User panel, can be turned upwards 5 Grounds container 7 Drip tray with drip grid | <ul style="list-style-type: none"> 2 Touch screen 4 Beverage outlet, manual up/down movement or optional automatic height adjustment (AHA) 6 Cup positioning aid for one or two cups |
|--|---|

6.4.2 Operating elements behind the user panel



Fig. 6: Machine operating elements

- | | |
|--|---|
| <ul style="list-style-type: none"> 1 USB port 3 Manual grinding level adjustment for centre grinder (standard equipment) | <ul style="list-style-type: none"> 2 Release lever for bean hoppers and powder containers 4 Manual grinding level adjustment for the optional right grinder |
|--|---|

- 5 On/Off switch
(press and hold for 4 s to switch off)

If the machine is equipped with the optional electric grinding level adjustment function, the adjustment devices for manual grinding level adjustment are not available. During initial commissioning, the service technician calibrates the grinding level using a reference beverage. The grinding level for the various recipes can then be adjusted electrically to a finer or coarser value in the beverage settings.

6.4.3 Bean hoppers with integrated manual inlet

The center bean hopper with integrated manual inlet is standard. The opening for the Coffeepure cleaning tab inlet is the same as the manual inlet.

Bean hopper and powder container lids are available with a closing device as an option.



Fig. 7: Bean hoppers with integrated manual inlet

- 1 Center bean hopper
- 2 Manual inlet for:
 - Ground coffee (e.g. decaffeinated coffee)
 - Cleaning tablet insert (Coffeepure tab)

6.4.4 User interface

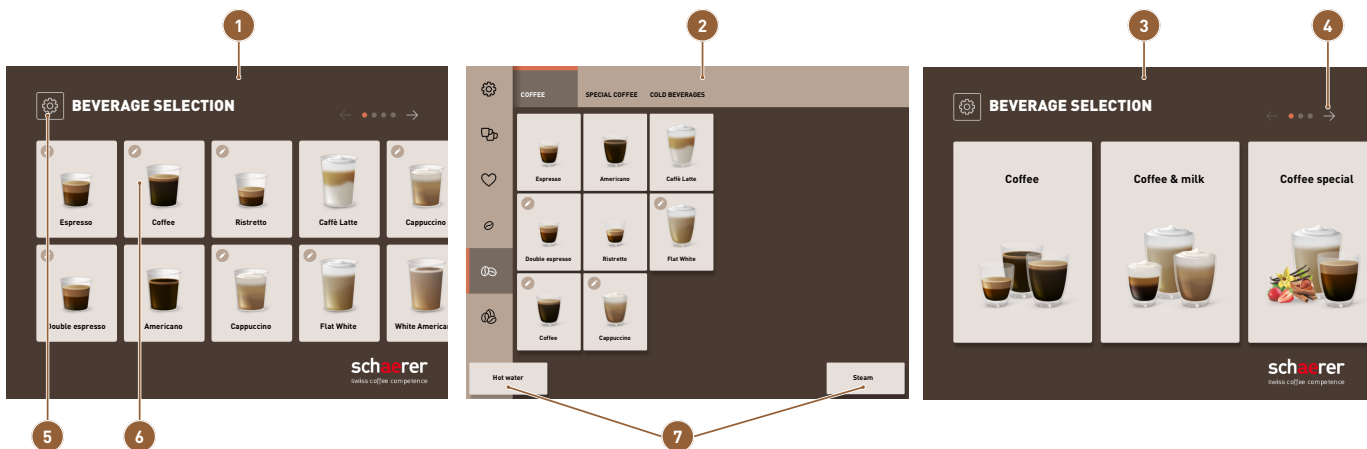

Fig. 8: Overview: user interface

- 1 User interface for beverage selection in Guest mode
- 2 User interface in Staff mode

- 3 User interface in Guest mode with selection via beverage groups
- 4 Navigation to the next or previous screen
- 5 Access to Service menu
- 6 Beverage button with symbol or text only
- 7 Dispensing of hot water or steam

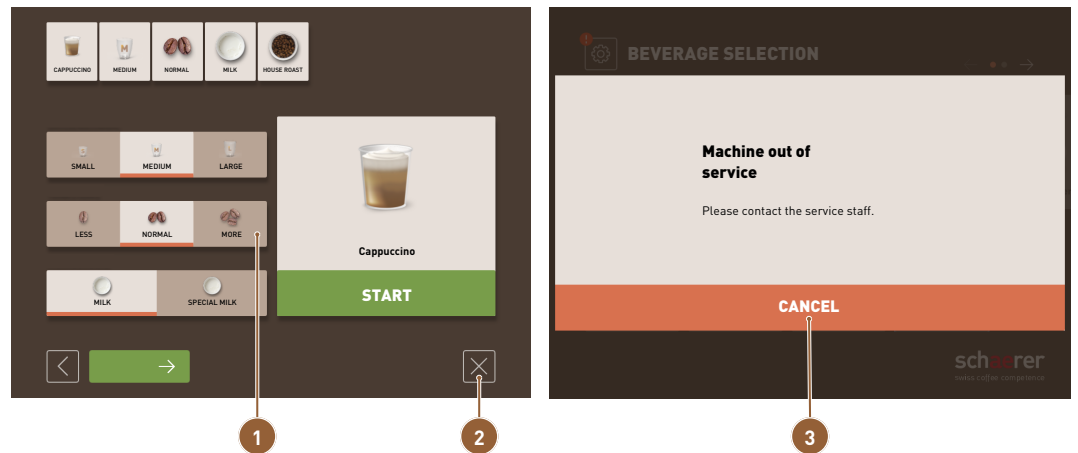

Fig. 9: Overview: operating functions on the interface

- 1 Selection of beverage options
- 2 Button [X]: Back or cancel
- 3 Error messages or instructions for action

6.5 Equipment variants installed at the factory

The following equipment variants are available ex works. They cannot be retrofitted at a later date.

6.5.1 Schaerer Coffee Soul with 10-inch display



Fig. 10: Schaerer Coffee Soul with 10-inch display

The standard version of the Schaerer Coffee Soul with the 10-inch display is equipped with décor elements according to the configuration and a 10-inch touch screen.

Various options can be configured while ordering the machine.

6.5.2 Schaerer Coffee Soul with 12-inch display



Fig. 11: Schaerer Coffee Soul with 12-inch display

The standard version of the Schaerer Coffee Soul with the 12-inch display is equipped with chrome front elements, décor elements according to the configuration and a 12-inch touch screen.

Various options can be configured while ordering the machine.

6.5.3 Best Foam™ fresh milk system



The **Best Foam™** function allows for integrated automatic milk heating and barista-style milk foaming.

Cold milk and cold milk foam can be dispensed.

A cooling unit is mandatory with the **Best Foam™** function.

6.5.4 Automatic height-adjustable beverage outlet (AHA)



Fig. 12: Automatic height-adjustable beverage outlet

With the **AHA** option, the optimum height of the beverage outlet is automatically adjusted to the selected beverage.

6.5.5 Steam wand

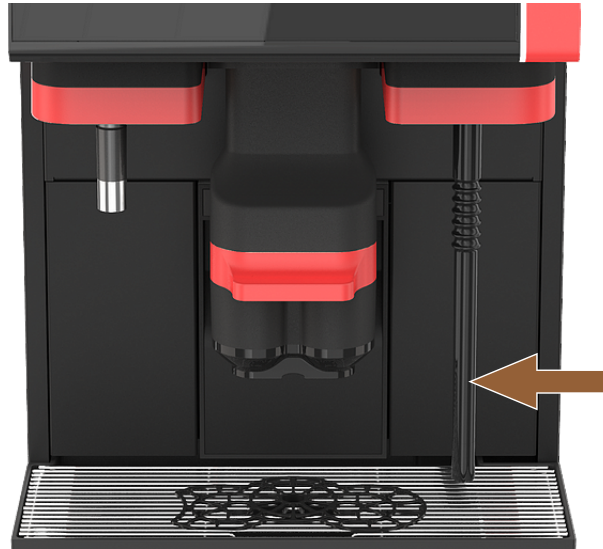

Fig. 13: Steam wand

The machine can optionally be equipped with a steam wand.

The steam wand is mounted to the right of the beverage outlet.

The steam wand function allows for separate manual milk heating and barista-style milk foaming. The following steam wand versions are possible:

Powersteam

The steam output is started and stopped manually.

Autosteam

The steam output is started manually and stopped automatically by a temperature sensor when a programmable target temperature is reached.

Supersteam

The steam output is started manually and stopped automatically by a temperature sensor when a programmable target temperature is reached. In addition to the steam, air is blown in through an air pump.

6.5.6 Separate hot water outlet



Fig. 14: Hot water outlet

The separate hot water outlet enables manual dispensing to the left of the beverage outlet.

6.5.7 Additional water for preparing americanos

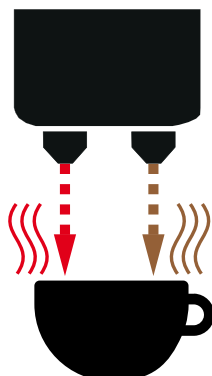

Fig. 15: Beverage dispensing: Hot additional water (red), coffee beverage (brown)

During beverage dispensing, hot additional water can be dispensed into the cup through the beverage outlet in addition to the beverage.

Hot additional water can be dispensed to prepare **americanos**.

The sequence of coffee and additional water is defined in the beverage configuration.

6.5.8 Additional grinders



Fig. 16: Equipment with second grinder and powder system

The machine can optionally be equipped with up to three grinders and three bean hoppers.

When equipped with two grinders, an additional bean hopper is available on the right. An optional powder container is always placed on the left-hand side. A second grinder can be used to process a second coffee bean type.

When equipped with three grinders, an additional bean hopper is installed on the left instead of the powder container.

6.5.9 Powder system 2000 g (choco or topping)



Fig. 17: Powder system

Choco and/or topping powder can be used with a powder system to the left of the standard center grinder.

6.5.10 Mixing cup for powder or topping system

The machine can optionally be equipped with a choco or topping powder system. A mixing cup is part of the equipment in this case.



Fig. 18: Operating elements on mixing cup for powder or topping system

- | | |
|--------------------------------------|-----------------------------|
| 1 Mixing cup position in the machine | 2 Removal direction |
| 3 Water supply line | 4 Connection for mixing cup |
| 5 Choco/Topping line | 6 Ventilation |

The mixing cup must be removed from the machine upon instruction during the cleaning programme.

See also

📖 Display-guided cleaning [▶ 122]

6.5.11 Twin powder system



Fig. 19: Twin powder system

The **Twin powder system** provides two powder types in one container.

The powder container for Twin Choco or Twin Topping is divided in the center and has two compartments for different types of powder.

6.5.12 Hot & Cold (cold beverages)



The **Hot & Cold** function allows for hot and cold beverages to be dispensed alternately.

6.5.13 Flavour Point

The machine is optionally equipped with the **Flavour Point** syrup module. This allows various syrup ingredients to be used to flavor beverages.



Fig. 20: Operating elements on the Flavour Point

1 Connection for four adapters for syrup bottles or four hoses from the cleaning set

2 On/Off press switch

The device is placed directly under the machine as an under-counter solution.

6.5.14 Side cooling unit

The machine can also be operated with a side cooling unit as an optional accessory.



Fig. 21: Right/Left side cooling unit

The side cooling unit can be placed on the left, on the right, between two machines (Centre Milk) and as an under-counter cooling unit. The cooling unit features a 10 l milk container.

The machine is supplied with a right machine connection as standard.

The right side cooling unit does not require additional adjustments.

Placing the side cooling unit on the left requires additional adjustment of the milk hose guide in the machine.



Conversion of the machine

Placing the cooling unit anywhere other than to the right of the machine requires conversion work.

The description of the conversion work and the necessary components are enclosed with the side cooling unit.



Fig. 22: Overview of the side cooling unit

1 Standby / Increase operating temperature button	2 Set button
3 Defrost / Reduce operating temperature button	4 Toggle switch for switching on/off

6.5.15 Side cooling unit for Centre Milk (CM)



Fig. 23: Side cooling unit for Centre Milk (CM)

Two machines can be operated with a side cooling unit with Centre Milk as an optional accessory. The additional side cooling unit is placed between two machines, where it supports the Centre Milk function.

The side cooling unit with Centre Milk equipment provides a simultaneous milk supply for two machines.



Conversion of the machine

Placing the cooling unit anywhere other than to the right of the machine requires conversion work.

The description of the conversion work and the necessary components are enclosed with the side cooling unit.

6.5.16 Under-counter cooling unit (UC)

The machine can also be operated with a under-counter cooling unit as an optional accessory.



Fig. 24: Under-counter cooling unit

The under-counter cooling unit is placed under the machine in a counter.

The under-counter cooling unit with Centre Milk equipment provides a milk source for two machines.



Conversion of the machine

Placing the cooling unit anywhere other than to the right of the machine requires conversion work.

The description of the conversion work and the necessary components are enclosed with the side cooling unit.

6.5.17 Under-machine cooling unit

The machine can optionally be operated with an under-machine cooling unit.



Fig. 25: Under-machine cooling unit

The under-machine cooling unit is placed directly under the machine. The under-machine cooling unit features a 9.5 l milk container.

The machine is delivered with a milk connection at the right by default.



Fig. 26: Under-machine cooling unit overview

- | | |
|---|---|
| 1 Front side of under-machine cooling unit | 2 Closing device |
| 3 Under-machine cooling unit with open door | 4 Milk hose adapter connection |
| 5 On/Off button (in the top door rebate) | 6 Back of under-machine cooling unit |
| 7 CAN connections (in the top device rebate) | 8 Thermostat |
| 9 Power connection | |

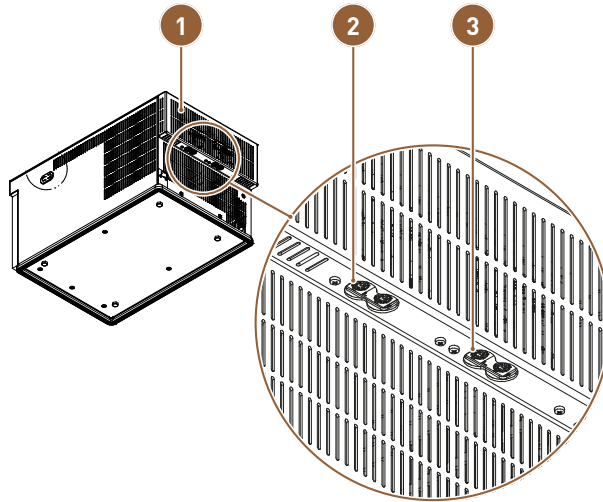

Fig. 27: CAN connections

- | | |
|---|---------------------------|
| 1 Back of under-machine cooling unit | 2 CAN connection 1 |
| 3 CAN connection 2 | |

6.5.18 Cup & Cool

The machine can optionally be operated with the Cup & Cool optional accessory.



Fig. 28: Cup & Cool

The Cup & Cool optional accessory is a combination of a cup warmer and a cooling unit.

Cup & Cool is available in narrow and wide variants and is placed to the left of the machine.

The wide variant is available with the Centre Milk option and is placed between two machines in this version.



Conversion of machine

Placement of the cooling unit between two machines requires machine conversion.

The description of the conversion work and the necessary components are enclosed with the side cooling unit.



Fig. 29: Cup & Cool front side with open cooling unit

1 Heatable bases

2 Closing device

3 Cup warmer On/Off button

4 Cooling unit On/Off button

5 Milk hose adapter connection

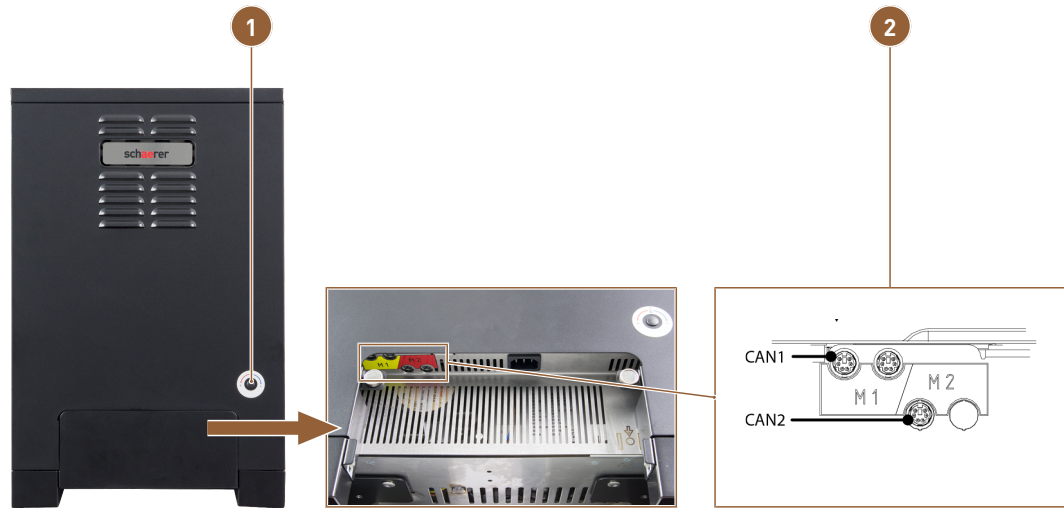

Fig. 30: Back [Cup & Cool]

1 Thermostat

2 CAN connection 1 and CAN connection 2 (Centre Milk)

6.6 Retrofittable equipment variants

All equipment variants that can be retrofitted to the machine are described below.

6.6.1 Lockable bean hoppers



Fig. 31: Lockable bean hoppers

The bean hoppers can optionally be equipped with a closing device.

6.6.2 Brewing accelerator



The **brewing accelerator** allows for more efficient dispensing of large beverages (e.g. americanos) with improved beverage quality. Additional hot water is fed into the coffee outlet after the brewing unit.

6.6.3 Drip tray with easy access







Fig. 32: Easy access operating unit

The drip tray collects spilled beverages, drips and cleaning water.

The drip tray must be connected to a waste water hose during installation, which is then attached directly to the waste water connection or fed into an external waste water tank if this option is available.

The machine is equipped with an additional **easy access** operating unit on the front that enables navigation on the screen, making it possible for persons with disabilities to operate it.

Button	Function
	Navigates back in the menu.
	Navigates forward in the menu.
	Confirms the selection.
	Deletes the last input. Press and hold to return to the main menu.

6.6.4 Decor elements



Fig. 33: Decor elements

Decor elements can be used to adapt the machine to its surroundings.

Different colors are available.

6.6.5 External waste and drinking water tank monitored

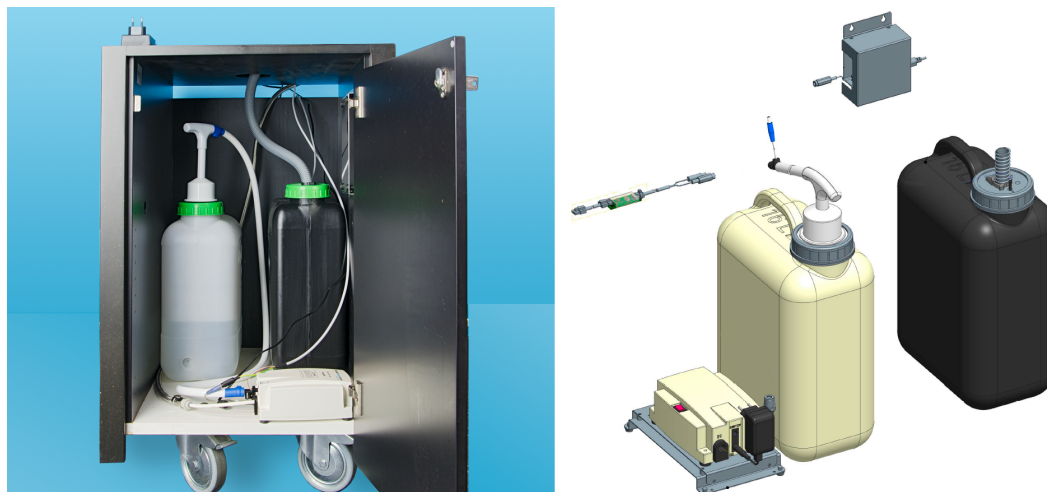

Fig. 34: External waste water and drinking water tank

The machine can also be used in mobile applications thanks to the optional device with the external waste and drinking water tanks.

The fill level of both tanks is monitored.

The equipment variant can be retrofitted from software version v2.0.

6.6.6 Under-counter grounds disposal

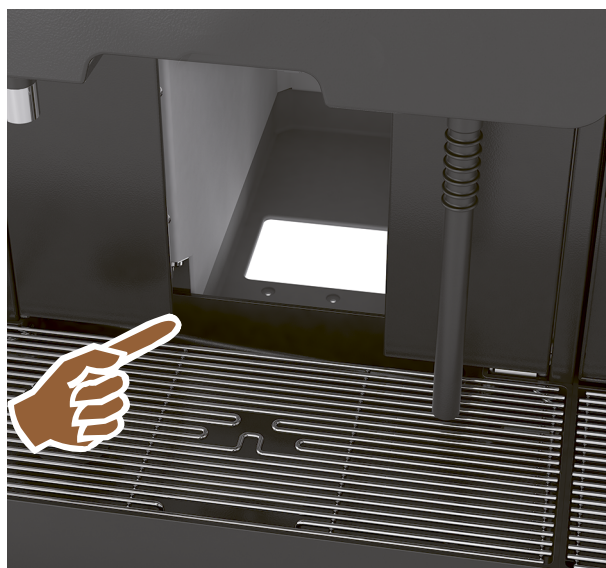

Fig. 35: Under-counter grounds disposal

The grounds container and the machine base have an opening that continues into the counter. The coffee grounds are collected in a large container under the counter.

An **under-counter grounds disposal** unit increases the capacity for the ejected coffee cakes.

6.6.7 Machine feet



Fig. 36: Machine feet

The machine feet increase the distance to the standing surface. The machine feet are available in heights of 40/70/100 mm. Machine feet are mandatory when using under-counter accessories.

6.6.8 Cup positioning aid

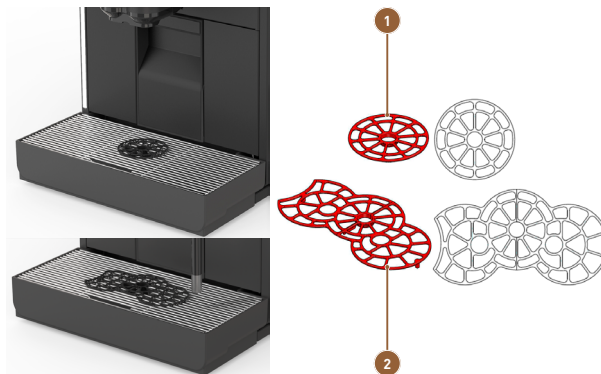

Fig. 37: Cup positioning aid

1 Single cup positioning aid

2 Cup positioning aid for two cups

Various cup positioning aids for snapping into the cup platform for one or two cups or mugs are available as an option.

The two-cup positioning aid is supplied as standard.

6.6.9 Schaefer Coffee Link (data exchange)



The **Schaefer Coffee Link** digital solution provides comprehensive information for quality assurance as well as for monitoring and optimizing individual business processes.

Various types of data can be read from the machine via the Schaefer **Coffee Link** web portal.

6.6.10 Payment systems



Commercially available **payment systems** in accordance with the MDB standard can be connected.

Possible interfaces:

- MDB-S
- DIVA 2
- DIVA2 Max

Connection to dispensing and cash register systems:

- Via e-protocol
- Via CSI protocol

Coin and token testers or coin changers can be placed to the left or right of the machine.

6.6.11 Cup warmer

The machine can also be operated with a cup warmer as an optional accessory.



Fig. 38: cup warmer

The cup warmer can be placed to the left or right of the machine and is available in narrow and wide versions.

The narrow cup warmer offers space for up to 264 coffee cups. The wide cup warmer offers space for up to 320 coffee cups.

The stainless steel bases of the cup warmer have a coating to reduce fingerprints and contamination on the surface.



Fig. 39: Overview of cup warmer

1 Front side of the cup warmer

2 Heatable bases

3 Back of the cup warmer

4 On/Off button

5 Activate/Deactivate lighting button

6.6.12 ProCare overview



Fig. 40: ProCare overview

1 Cam lock

2 Hose adapter

3 Connections for Plug & Clean

4 CAN bus connection cable

5 Power cable

The Plug & Clean connections are used for complete hose cleaning. The two milk hoses are connected here and are also cleaned when Plug & Clean cleaning is selected.

The hose adapters are the connecting piece between the milk hose and the suction pipe. The suction pipe is led into the milk cooling box.

The ProCare unit is connected to the power supply with the power cable.

The CAN bus connection cables enable exchange of data and commands between the machine and the optional accessories.

The cam lock locks the drawer when closed, preventing unauthorized access.

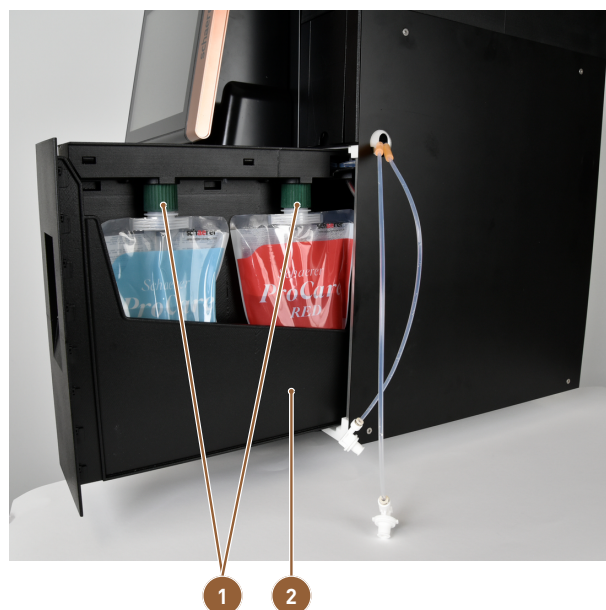

Fig. 41: Drawer with pouches

1 Cap nuts

2 Collecting tray

Both ProCare cleaning pouches are located in the collecting tray. The ProCare cleaning pouches are attached to the connections on the drawer housing and secured with the cap nuts.

The collecting tray also acts as a collecting basin in the lower area. If liquids accidentally escape from the cleaning pouches, they are collected. The sensor issues an error message at the same time.

The BLUE ProCare cleaning pouch is placed over the coupling nozzle and tightened with the cap nut. The coupling is monitored by a sensor.

The RED ProCare cleaning pouch is placed over the coupling nozzle and tightened with the cap nut. The coupling is monitored by a sensor.

7 Transport

This chapter contains information on safe and correct transport, e.g. when moving or for service work.

7.1 Scope of delivery of accessories

Accessories for machine

Quantity	Designation
1	Drip tray

Instructions

Quantity	Designation
1	Machine operating instructions
1*	Optional accessory operating instructions (cup warmer + Cup & Cool)
1*	Cooling unit operating instructions

Scope of delivery of additional parts

Quantity	Name
1	Measuring spoon

Scope of delivery of cleaning/maintenance

Quantity	Designation
1	Brush 75-40 (brewing chamber)
1	Brush (beverage outlet)

Scope of delivery of cleaning/maintenance without ProCare*

Quantity	Coffee system cleaning
1	Delivery set of Coffeepure tabs for 100 cleanings

Quantity	Milk system cleaning
1****	Cleaning container 1 l with cover blue
1****	Delivery set of Milkpure powder for 100 cleanings
1	Special milk cleaning liquid, 3345340000

Scope of delivery of cleaning/maintenance with ProCare*

Quantity	Designation
1	Cleaning pouch ProCare blue, 3370101044 (UFI: GPF0-V0QD-700S-5Y0U)
1	Cleaning pouch ProCare red, 3370101045 (UFI: YKFO-D00Y-X009-HMEQ)

Scope of delivery for powder system*

Quantity	Designation
1	Powder container outlet orifice

Descaling accessories***

Quantity	Designation
1	Descaling cartridge****

* Optional, depending on machine version

** Language-dependent article number

*** Not contained in the scope of delivery

**** Omitted when using ProCare

*

7.2 Conditions for transport



WARNING

Risk of injury due to insufficient qualification!

Improper handling can lead to considerable personal injury and property damage.

The following activities may only be carried out by specialist staff.



WARNING

Health problems caused by heavy machine!

The weight of the machine exceeds the permissible load that a single person is allowed to lift or carry alone. The load of the machine may cause health problems when lifted or carried by a single person.

 Do not lift or carry the machine alone.

 Only lift or carry the machine with two people.



CAUTION

Risk of injury during transport!

Improper transport can lead to injuries.

 Observe the general health and safety regulations in accordance with local regulations.



CAUTION

Risk of injury due to machine tipping over!

Improper lifting of the machine can cause it to tip. A tipping or falling machine can cause injury.

 Do not lift the machine alone.

 Only lift the machine with two people.

**NOTE****Property damage due to improper transport!**

Improper transport during relocation of the machine can damage it.

- 👉 Use a trolley to transport the machine.
 - 👉 Secure the machine on the trolley and pull the trolley.
-
- 🔧 Before moving the machine, separate the connections for the drinking water supply, the power supply and the waste water outlet.
 - 🔧 Make sure that the new location has no obstacles or uneven spots.

8 Installation and commissioning



WARNING

Risk of injury due to insufficient qualification!

Improper handling can lead to considerable personal injury and property damage.



The following activities may only be carried out by service staff.



WARNING

Health problems caused by heavy machine!

The weight of the machine exceeds the permissible load that a single person is allowed to lift or carry alone. The load of the machine may cause health problems when lifted or carried by a single person.



-  Do not lift or carry the machine alone.
-  Only lift or carry the machine with two people.



CAUTION

Risk of injury due to machine tipping over!

Improper lifting of the machine can cause it to tip. A tipping or falling machine can cause injury.



-  Do not lift the machine alone.
-  Only lift the machine with two people.



NOTE

Property damage due to non-compliance with sanitary regulations!

Improper sanitary installation of the machine may result in property damage.

-  Install the machine so that the installation complies with applicable federal, state, or local sanitary regulations.
-  Ensure that sufficient backflow preventers are installed.

The machine operator must commission the preliminary work for the connections (electricity, water, waste water) on the manufacturer side. Preliminary work must be carried out by licensed installers observing all general, national as well as locally applicable regulations.

Installation of the mains water supply to the drinking water and waste water supply must be carried out by specialist staff or the service department of the manufacturer.

Service technicians of the manufacturer or its service partner may only connect the machine to the prepared connections. They are neither authorized to carry out installation work on the manufacturer side, nor are they responsible for its execution.

8.1 Unpacking



CAUTION

Cuts and eye injuries from packaging material!



Sharp-edged packaging material can cause injuries. Cutting tensioning straps can cause eye injuries.



Wear gloves and safety goggles when unpacking.

8.1.1 Unpacking machine

- ☞ Unpack the machine.
- ☞ Remove the supplied accessories from the accessory box.
- ☞ Check the remaining contents of the packaging for supplied accessories.
- ☞ Check the delivery for completeness and intactness.
- ☞ If in doubt, do not operate the machine and contact your service partner.
- ☞ Keep the original packaging for possible return.

8.1.2 Unpacking accessories

The following accessory parts are delivered:

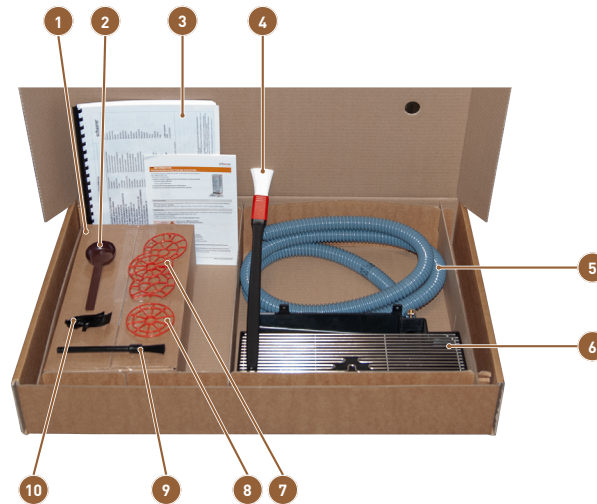

Fig. 42: Accessories included in delivery

- | | |
|--|--|
| 1 Cleaning product (according to machine equipment) | 2 Spoon for ground coffee for manual inlet |
| 3 Operating instructions and declaration of conformity | 4 Brush for cleaning inside of grounds container |
| 5 Dirty water hose | 6 Drip tray (dirty water hose pre-assembled) |
| 7 Cup positioning aid for two cups | 8 Single cup positioning aid |
| 9 Small brush | 10 Milk hose guide to the left |

8.2 Setup

The following conditions apply to the location of the machine:

- The machine must not be used outdoors.

- The installation surface must be stable, horizontal and level so that it cannot become deformed under the weight of the machine.
- The installation surface must be water-resistant and heat-resistant.
- The machine must not be set up on hot surfaces or near heat sources.
- The machine must not be installed on a surface which is sprayed or cleaned with a water hose, a steam jet device, a steam cleaner or similar.
- The machine must be set up so that it is protected from spray water.
- The machine must be set up in such a way that it can be supervised by trained staff at all times.
- The required supply connections must be led up to 100 cm (39.4") to the machine location in accordance with the manufacturer-side installation diagrams.
- The locally applicable kitchen regulations must be observed.
- Clearances for maintenance work and operation must be maintained:
 - Enough space must be left at the top for filling the coffee beans or powder; 20 cm (7.87") is recommended.
 - A distance of at least 5 cm (1.97") must be left from the rear of the machine to the wall to allow for sufficient air circulation.
 - If the machine connections are to run downward through the counter, the space requirements of the lines that can restrict usable space in the structure underneath must be observed.
 - When installing a water filter, see the operating instructions for the water filter.

See also

📖 Ambient conditions [▶ 22]

8.3 Installation requirements

The machine must be installed in accordance with the applicable national and local electrical and plumbing regulations. This also includes adequate backflow protection.

All connections on the machine side are ready for use on delivery.

The following connections are required on the installation side:

Electrical system

- Socket for power plug or fixed connection with main switch

The serial plate provides information on the required maximum fuse protection and the required minimum conductor cross-section.

Water

- Mains water supply 3/8" or connection to the external drinking water tank
- Siphon or external waste water tank for dirty water hose Ø 40 mm

Optional accessories

- Optional interface for communication between the machine and the optional accessories
- ☞ For better accessibility, position the rear of the machine approx. 5 cm (2") above the support plate.
- ☞ Prepare the connections on the installation side.

See also

📖 Setup [▶ 53]

8.4 Connecting power



DANGER

Danger to life from electrocution!

There is a risk to life due to electrocution when connecting the machine.

- ☞ Make sure that the phase is fused with the ampere value specified on the serial plate.
- ☞ Make sure that the device can be disconnected from the power supply with all poles.
- ☞ Make sure that the manufacturer-side electrical system is designed in accordance with the regulations of the respective country.
- ☞ Route the connection through a ground fault circuit interrupter.
- ☞ Never operate a device with a defective connection cable. Have a defective connection cable or plug replaced immediately by a qualified service technician.
- ☞ The manufacturer advises against the use of an extension cord. If an extension cord is used in spite of this advice (minimum cross-section: 1.5 mm² / 14 AWG), observe the manufacturer data for the cable (operating instructions) and comply with the locally applicable regulations.
- ☞ Attach the connection cable in such a way that nobody can trip over it. Do not pull the cables over corners and sharp edges, do not pinch them and do not let them hang freely in space. Do not place cables on hot objects and protect them from oil and aggressive cleaning products.
- ☞ Never lift or pull the device by the connection cable. Never pull the plug out of the socket using the connection cable.
- ☞ Never touch the cable or plug with wet hands. Never insert wet plugs into the socket under any circumstances.



DANGER

Danger to life due to defective or non-original connection cable!

If the connection cable is defective or not original, there is a risk of electrocution and fire.

- ☞ Only use original connection cables. The country-specific original connection cable is available from the service partner.
- ☞ Connection cables that can be plugged in at both ends can be replaced by the customer.
- ☞ Have permanently connected connection cables replaced by a service technician.



WARNING

Risk of injury due to insufficient qualification!

Improper handling can lead to considerable personal injury and property damage.

The following activities may only be carried out by a qualified electrician.

The electrical connection must be made in accordance with the regulations of the respective country. The voltage specified on the serial plate must match the supply voltage at the installation site. The power socket and power switch must be accessible to the operator at the installation site.

- ☞ Establish the power connection.

Make sure that the manufacturer-side electrical system is designed in accordance with IEC 364 (DIN VDE 0100). To increase safety, a ground fault circuit interrupter with a nominal residual current of 30 mA (EN 61008) should be connected upstream of the device. Type B residual current circuit breakers ensure response even with smooth DC residual currents. This ensures a high level of safety.

See also

 Product description [▶ 26]

 Technical data [▶ 18]







8.5 Connecting water



CAUTION

Health problems due to contaminated water!

Improper handling of water can lead to health problems.







-  Make sure that the water is free of dirt and bacteria.
-  Do not connect the machine to pure osmosis or other aggressive types of water.
-  Make sure that the carbonate hardness is between 4 and 6 °dKH or 8 and 12 °fKH.
-  Make sure that the total hardness is higher than the carbonate hardness.
-  Do not exceed the maximum chlorine content of 50 mg per liter.
-  Make sure that the pH value is between 6.5 and 7 (pH neutral).
-  Machines with drinking water tank (internal and external): Fill the drinking water tank with fresh water every day and rinse it thoroughly before filling.



NOTE

Property damage due to poor water quality!

The machine can be damaged if contaminated water or water with incorrect water values are used.

-  Check the recommended water quality and optimize it if necessary.
-  The water must be free of dirt and the chlorine content must not exceed the local regulations on the maximum permitted chlorine content.
-  Do not connect the machine to pure osmosis or other aggressive types of water.
-  The carbonate hardness must not exceed 4 – 6 °dKH (German carbonate hardness) or 8 – 12 °fKH (French carbonate hardness) and the value of the total hardness must always be higher than the carbonate hardness.
-  The minimum carbonate hardness is 4 °dKH or 8 °fKH.
-  The pH value must be between 6.5 and 7.
-  Always use the new hose set supplied with the machine (fresh/waste water hose).

Drinking water connection

The water connection must be made in accordance with the applicable regulations and the regulations of the respective country. If the machine is connected to a newly installed water line, the line and intake hose must be rinsed thoroughly to ensure that no dirt gets into the machine.

The machine must be connected to an installed drinking water line with a shut-off valve. Installation is done using the assembled pressure hose and the G 3/8" screw connection.

Waste water outlet

The machine requires a waste water outlet. With a fixed connection, the supplied temperature-stable dirty water hose is connected to a siphon on the installation side. The waste water hose should slope to the connection in order to prevent the siphon effect and must be fixed above the water level in the siphon system.

When using an external waste water tank, the machine is connected directly. A corresponding fill level monitor is available.



The **Supplementary Instructions for Water Quality** contain information on recording water values and the use of filter techniques. The supplementary instructions can be requested from the manufacturer or downloaded directly from the download portal.

8.5.1 Variant with external drinking and waste water tank

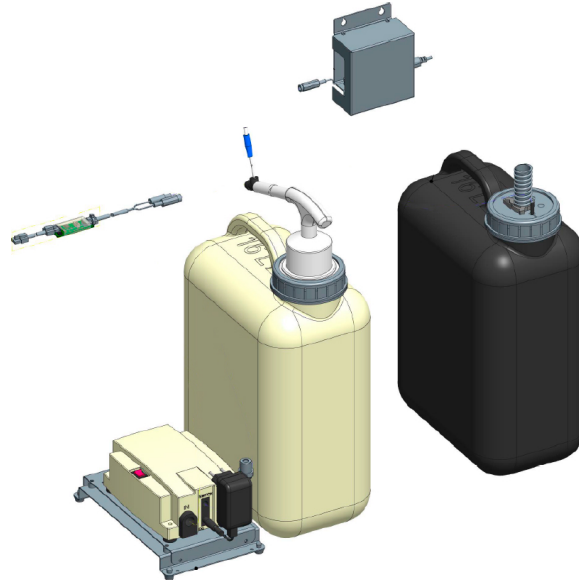

Fig. 43: External drinking and waste water tank

The machine can optionally be operated with a monitored external drinking and waste water tank.

☞ Connect the drinking and waste water connections of the machine directly to the water tanks.



The conversion instructions for the **monitored drinking and waste water tank** contain information on setting up and connecting the external drinking and waste water tanks. The retrofit instructions can be requested from the manufacturer or downloaded directly from the download portal.

8.6 Assemble drip tray

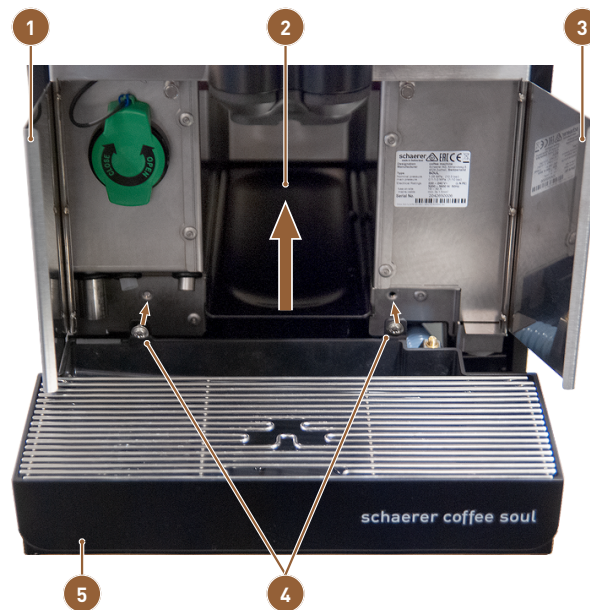

Fig. 44: Assemble drip tray

- | | |
|--------------------|--|
| 1 Front door left | 2 Device base insert for grounds container |
| 3 Front door right | 4 Mounting screws (2x) |
| 5 Drip tray | |

☞ Open both **front flaps**.

✓ The holes for the **mounting screws** are visible.

- ☞ Guide the dirty water hose on the **drip tray** backwards through the machine.
- ☞ Position the **drip tray** and press it onto the machine. At the same time, lift the **device base insert** for the grounds container slightly.
- ☞ Secure the **drip tray** with the two **mounting screws**.
- ✓ The **drip tray** is mounted.

8.7 Connecting milk system

The optional milk hose is removed from the squeeze valve for transportation. Before commissioning, the milk hose must be correctly reinserted into the squeeze valve, see figure below. Machine equipment options with Twin Milk contain two squeeze valves and two milk hoses.

- ☞ Lift the user panel.

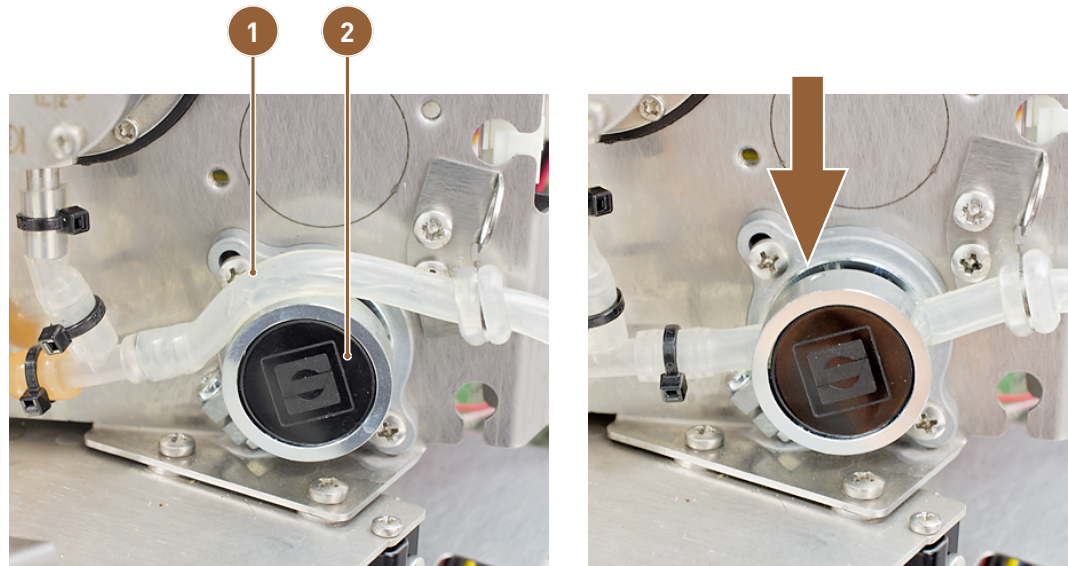

Fig. 45: Inserting milk hose into squeeze valve (Single Milk)

1 Milk hose

2 Squeeze valve

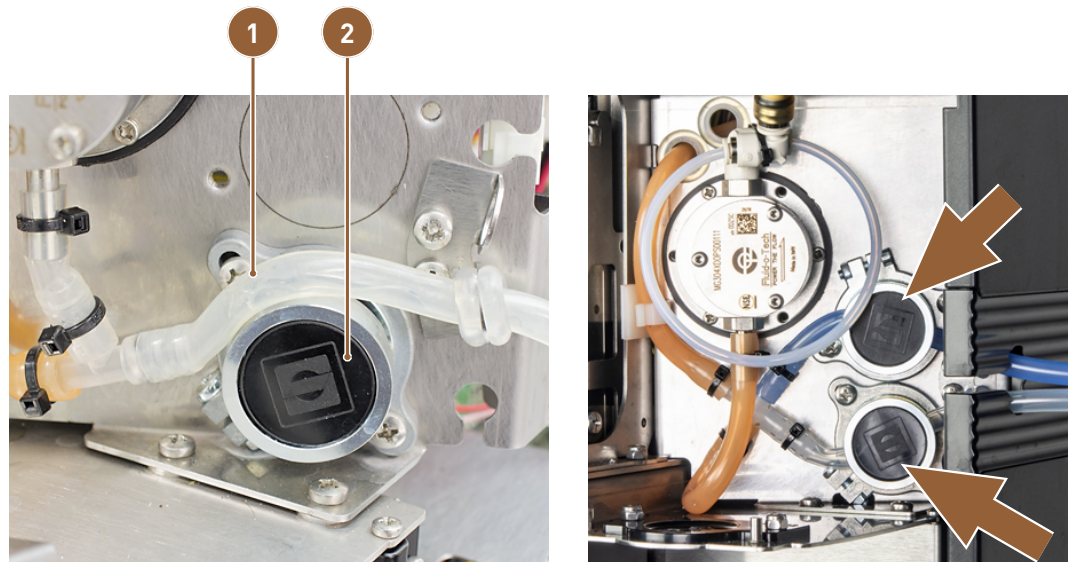

Fig. 46: Inserting milk hoses into squeeze valves (Twin Milk)

1 Milk hose

2 Squeeze valve

- ☞ Pull the black cover on the right forwards without tools. The milk pump and squeeze valve are accessible.
- ☞ For Single Milk systems: Insert the milk hose into the squeeze valve as shown.

- ☞ For Twin Milk systems: Insert the two milk hoses into the two squeeze valves.

See also

- 📖 Opening and closing the operating unit [▶ 70]

8.8 Connecting ProCare unit

- 📖 The machine is switched off.
- ☞ Connect the ProCare unit to the machine.
- ☞ Connect the ProCare unit to the cooling unit.
- ☞ Connect the milk hoses.
- ☞ Connect a CAN bus connection cable to the machine.
- ☞ Connect the other CAN bus connection cable to the optional accessory (e.g. milk system).
- ☞ Connect the power plug to the power supply.
 - ✓ The module is switched on.
- ☞ Switch the machine on.
 - ✓ The modules connects to the machine.
- ☞ Start the machine commissioning routine.



Additional information on retrofitting a coffee machine with the ProCare unit or the side cooling unit with the ProCare unit can be found in the separate ProCare installation instructions.

8.8.1 Connecting ProCare unit to machine

The following requirements must be fulfilled for a machine with ProCare preparation:

- The metal bracket for holding the ProCare unit is installed in the machine.
- The side panel of the machine already has the hole for the ProCare unit mounting screw.
- The hoses for connecting to the ProCare unit are routed out of the side of the machine and fastened with cable ties.

Connecting ProCare unit

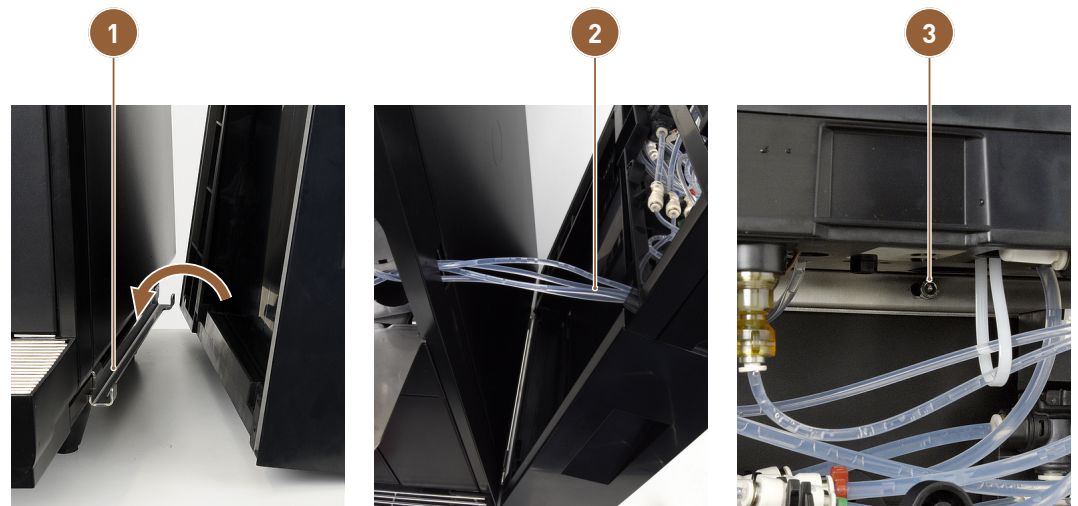

Fig. 47: Fastening ProCare unit to machine

1 Connecting plate

2 Teflon hoses to ProCare unit

3 Mounting screw

- ☞ Snap the ProCare unit into the connecting plate on the machine.
- ☞ Insert the Teflon hoses into the ProCare unit.

- ☞ Screw the ProCare unit to the machine with the mounting screws.

Connecting hoses

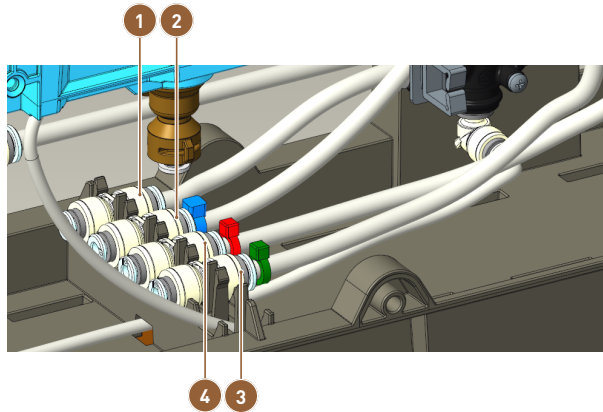

Fig. 48: Assignment of hose connections

1 White: milk	2 Blue: water
3 Green: coffee	4 Red: descaling

- ☞ Cut the hoses to length so that they can be arranged in a loop.
- ☞ Measure the length of the hoses and note the length. The hose length can be set in the machine configuration for optimal operation of the ProCare unit.
- ☞ Place the hoses in a loop in case you ever need to remove the module.
- ☞ Connect the hoses according to the marking.
- ☞ Make sure that the hoses do not block the closing mechanism of the front panel.
- ☞ Open the machine configuration and navigate to the system settings.
- ☞ Open the cleaning settings.

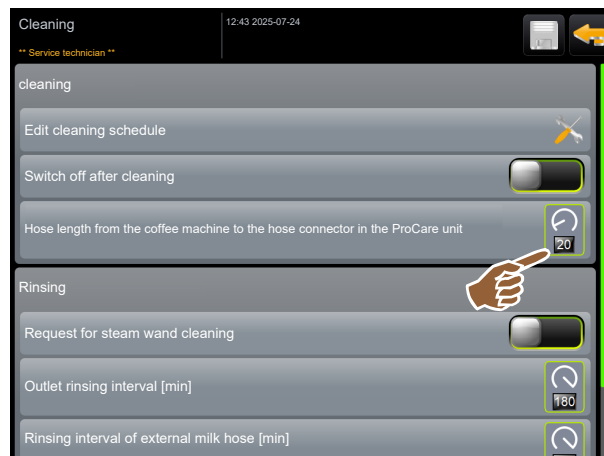

Fig. 49: Setting hose length for ProCare unit

- ☞ Enter the hose length in the input field.

8.8.2 Connecting ProCare unit to cooling unit

Assembling cooling unit

- ☞ Assemble the metal bracket on the side of the ProCare unit where the cooling unit is attached.
- ☞ Close the ProCare unit with the supplied side panel depending on the positioning of the right housing or the left housing.
- ☞ Attach the cooling unit to the ProCare unit.

Adjusting milk hose



Fig. 50: Milk hose in cooling unit

1 Hose 4/8 silicone orange

- ☞ Install the milk hose and cut it to size so that it reaches the Plug & Clean connection on the ProCare unit.
- ☞ Cover the milk hose with the 4/8 silicone orange hose and clamp it into the recess in the cooling unit.

8.8.3 Connecting ProCare unit cable

Connect the power cable and CAN bus before switching on the device.

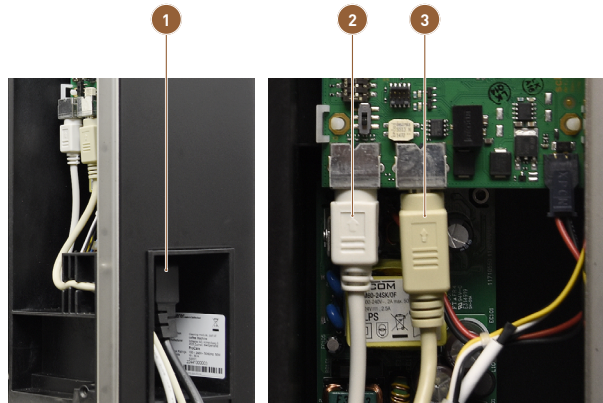

Fig. 51: Cable connections

- | | |
|--|---|
| <p>1 Power supply connection for cold device plug</p> | <p>2 CAN Mini-DIN 6-pole control cable 2 m</p> |
| <p>3 CAN bus cable from cooling unit</p> | |

- ☞ Connect the cold-device plug to the power connection on the back of the ProCare unit.
- ☞ Connect the CAN Mini-DIN 6-pole 2 m control cable to the ProCare unit.
- ☞ Connect the CAN bus cable of the cooling unit.

8.9 Installing optional accessories

All optional accessories with an integrated cooling unit or with feed pumps require a communication connection (CAN bus) to the machine. The connections are always serial.

8.9.1 Connecting optional accessories to power supply

All optional accessories require a 230 V / 50 Hz power connection. The power connection is made via a pre-assembled and tested connection cable that is supplied with the optional accessories.

8.9.2 Establishing communication connection (CAN bus)

All optional accessories with an integrated cooling unit or with feed pumps require a communication connection (CAN bus) to the machine. The connections are always serial.

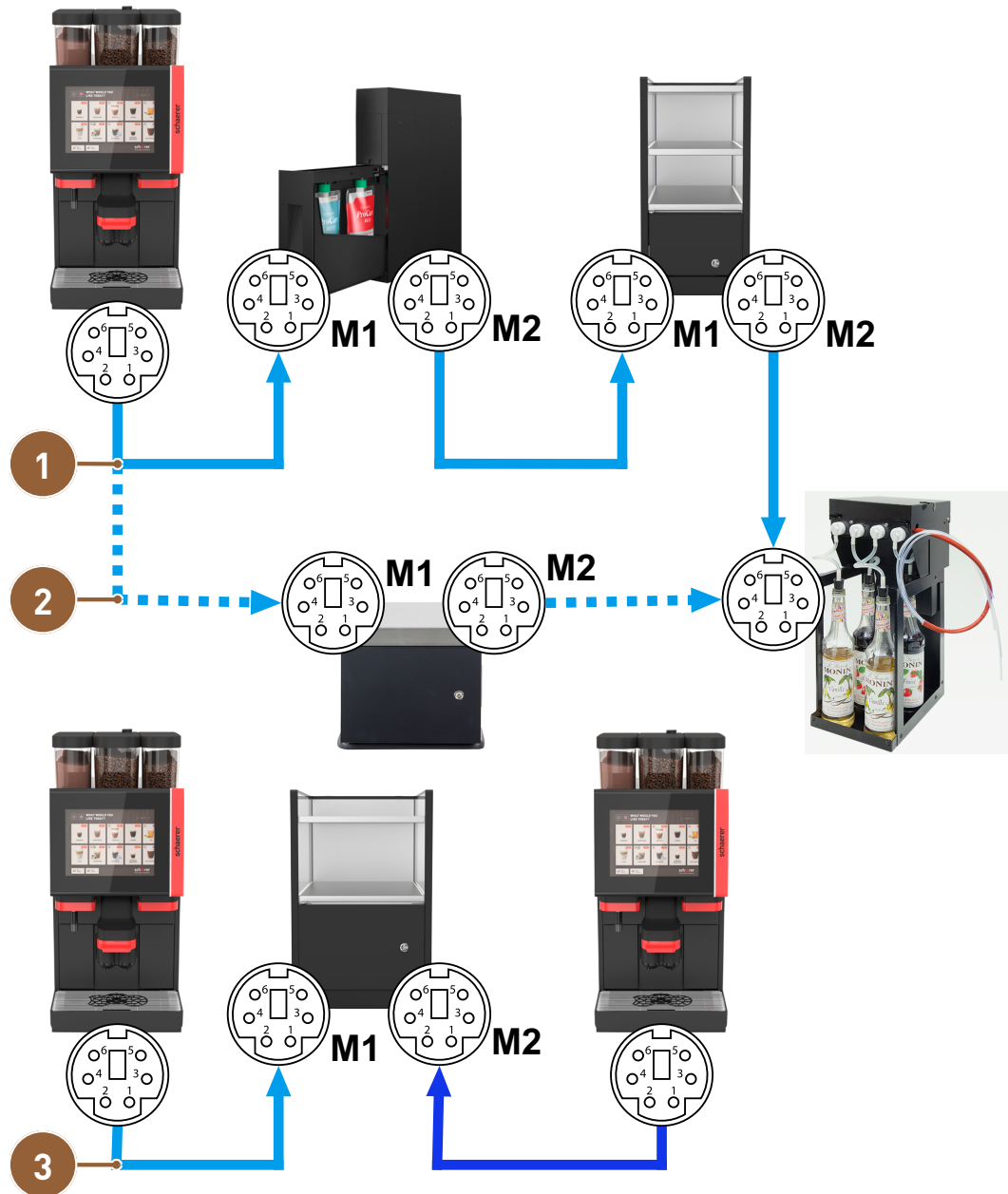

Fig. 52: CAN bus connections from the machine to optional accessories (example displays)

1 Example of CAN bus connection:

Machine with ProCare, Cup & Cool (narrow) and Flavour Point

2 Example of CAN bus connection:

Machine with under-machine cooling unit and Flavour Point

3 Example of CAN bus connection:

2 machines with Cup & Cool (Centre Milk)

- ☞ Establish the CAN bus connection using a control cable with a 6-pin DIN plug. To do this, connect the control cable to the communication interface of the machine.
- ☞ Connect the other end of the control cable to the desired optional accessory.
- ☞ If necessary, use another control cable with a 6-pole DIN plug to establish the connection from one optional accessory to another optional accessory.

The position of the connections on the optional accessories can be found in the product description of the respective optional accessories or in the operating instructions for the corresponding device.

See also

- ▣ ProCare overview [▶ 47]
- ▣ Cup & Cool [▶ 40]
- ▣ Under-machine cooling unit [▶ 39]

8.9.3 Connecting the Flavour Point 4-way UC (syrup module)

The Flavour Point 4-way UC is an equipment variant installed at the factory and cannot be retrofitted.

For correct hose laying, machine feet of at least 40 mm in height must be fitted to the machine.

Flavour Point hose connections

Prerequisite:

- The machine was prepared for the Flavour Point equipment variant at the factory.
- The necessary hose connections are led out of the right-hand side of the machine.

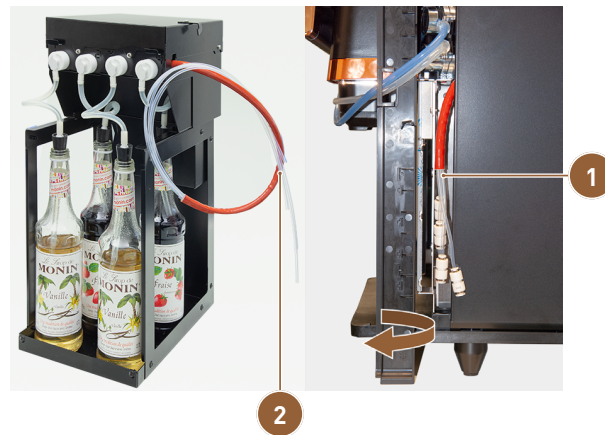

Fig. 53: Flavour Point SOUL hose connection

1 Plug-in connections on the right machine side

2 Flavour Point connection hoses

- ☞ Lift the bean hoppers and powder containers out of the machine.
- ☞ Loosen the four screws from the machine cover.
- ☞ Lift the cover slightly on the right-hand side.
- ☞ Slide the narrow casing strip on the right upwards and unlock it.
 - ✓ The plug-in connections led out of the machine are now accessible on the right side of the machine.
- ☞ Plug the connection hoses from the Flavour Point into the prepared plug-in connections in an offset position.
- ☞ Refit the side panels on the right and the machine cover.
- ☞ Replace the bean hoppers and powder containers.
- ✓ The hose connection from the Flavour Point to the machine has been installed.

Syrup type labeling

The customer can label the device at the installation site using self-adhesive labeling strips.



Fig. 54: Labeling example for hose connections from syrup bottle to syrup pump

- ☞ Divide the labeling strips into 4 fields (4 pumps) of approx. 5 cm (2").
- ☞ Label the syrup pumps according to the type of syrup bottles connected.
- ✓ The syrup bottle to syrup pump hose connection is labeled.
- ✓ After cleaning, assignment to the syrup types is clearly visible.

8.10 Screen-guided commissioning

The machine is commissioned by the service technician on site at the premises of the operator. The commissioning program starts automatically when the machine is switched on for the first time. After display-guided commissioning, no beverages can be dispensed as no beverage recipes have been configured. A service technician configures and calibrates the beverage recipes together with the operator.

Service technicians can start the commissioning program manually at any time.

9 Operation

This chapter contains information on the various beverage preparation functions for daily operation of the machine.



CAUTION

Risk of injury due to slipping!

Leaking liquid can lead to a wet floor around the machine. This can lead to injuries from slipping and falling.

- ☞ Dry any spilled liquids on the floor immediately after spills occur.
- ☞ Indicate large quantities of leaked liquid on the floor with a mobile warning sign.



CAUTION

Risk of scalding due to hot fluid!

There is a risk of scalding in the dispensing area for beverages, hot water and steam.

- ☞ Never reach under the dispensing points during dispensing or cleaning.
- ☞ Always lock the control unit before cleaning to prevent accidental input.



CAUTION

Health hazard due to unsuitable products

The product containers and an optional manual inlet may only be filled with products that are intended for this purpose.

- ☞ Only make products which are suitable for consumption and the use of the machine.

See also

- ☞ Safety [▶ 12]

9.1 Recurring additional tasks

This chapter contains information on operating steps on the machine that are required regularly during daily operation.

9.1.1 Filling bean hopper



WARNING

Risk of crushing and cutting injuries from rotating grinding discs!



There is danger of crushing and cutting injuries due to rotating grinding discs in the grinder.

- ☞ Never reach into the bean hopper when the machine is switched on.
- ☞ Switch off the machine and disconnect the power plug before performing any work on the grinder.

**NOTE****Property damage due to foreign objects in bean hopper!**

Filling with foreign objects can cause the grinder to clog or block and destroy the grinder. These damages are excluded from the warranty.

- ☞ Never fill the bean hopper with anything other than coffee beans.



Fig. 55: Bean hoppers and powder containers with maximum fill level

- ☞ Refill the hopper as soon as possible.
- ☞ For lockable bean hoppers: Open the lock of the bean hopper with the key.
- ☞ Remove the cover of the bean hopper.
- ☞ If necessary, clean the bean hoppers and covers to remove coffee residue before filling.
- ☞ Fill the bean hopper with the intended type of coffee.
- ☞ Fill the hopper with no more than is needed for a day to ensure that the products remain fresh.
- ☞ Only add enough so that the contents do not touch the container cover.
- ☞ Always fill the container from front to back.
- ☞ Close the bean hopper with the lid.
- ☞ For lockable bean hoppers: Lock the bean hopper with the key.
- ✓ The bean hopper is refilled.

9.1.2 Filling powder container

**CAUTION****Risk of crushing due to rotating dosing screws!**

The dosing screws inside the powder container rotate. There is a risk of crushing when reaching in.

- ☞ Switch the machine off before reaching into the powder container.

**NOTE****Property damage due to clogging!**

Filling the machine with unsuitable coffee machine powder can cause the powder container or powder system to become clogged.

- ☞ Only fill the machine with powder that is suitable for use in automatic machines.
- ☞ Do not overfill the powder container.
- ☞ Do not press on the powder or compress it.



Fig. 56: Bean hoppers and powder containers with maximum fill level

- ☞ Variant with powder container locking mechanism: Open the powder container lock with the key.
- ☞ Remove the cover of the powder container.
- ☞ Fill the powder container with choco or topping powder.
- ☞ Only add so much that the contents do not touch the container cover.
- ☞ Close the powder container with the cover. Lock the powder container (if lockable).
- ✓ The powder container is filled and locked.
- ✓ The powder does not touch the cover.

9.1.3 Refilling water



NOTE

Property damage due to closed water line!

The machine can be damaged if the water pump runs dry.

- ☞ Before switching on the machine, make sure that the main water valve (tap) of the water supply line is open.

Variant with mains water supply

- ☞ Open the shut-off valve on the main water valve before switching on the machine.
- ☞ Close the main water valve at the end of the day.

Variant with external drinking water tank



Fig. 57: External drinking water tank

- ☞ Unscrew the cover of the external drinking water tank.
- ☞ Rinse the external drinking water tank thoroughly with fresh water every day.
- ☞ Clean the cover of the drinking water tank with fresh water.

- ☞ Fill the drinking water tank with fresh drinking water, making sure not to exceed the maximum fill level.
- ☞ Close the external drinking water tank with the cover.
- ☞ Reinsert the drinking water tank.

9.1.4 Filling BestFoam™ milk system



CAUTION

Risk of infection from contamination in the milk pump!

Contamination in the milk pump can lead to infections. Infections can trigger health problems.

- ☞ Always carry out cleaning after installation, commissioning or after recommissioning.
- ☞ Run the display-guided cleaning program before the first beverage dispensing process.



NOTE

Property damage due to milk that is not pre-cooled!

The cooling unit only maintains the temperature of pre-cooled milk.

- ☞ Only use milk that has already cooled down to at least 5 °C (41 °F) for refilling.

Maximum fill level of milk container

- Side cooling unit: Max. 10 l
- Cup & Cool: Max. 4 l
- Under-counter cooling unit (UC-CU): Max. 9.5 l
- Under-machine cooling unit (UM-CU): Max. 9.5 l

Refill milk system



Fig. 58: Filling side cooling unit

1 Side cooling unit milk container

2 Side cooling unit milk hose adapter

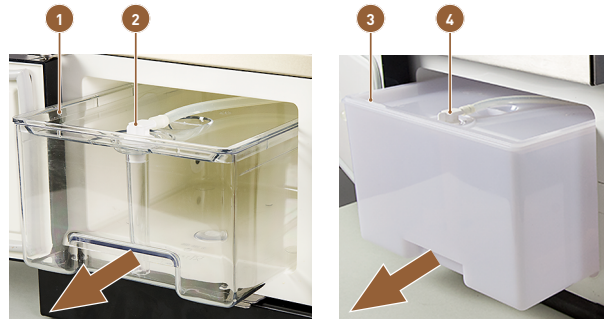

Fig. 59: Filling Cup & Cool / UM-CU / UC-CU

- | | |
|---|--|
| 1 Cup & Cool milk container 4 l | 2 Cup & Cool milk hose adapter |
| 3 Milk container UM-CU / UC-CU 9.5 l | 4 Milk hose adapter UM-CU / UC-CU |

- ☞ Open the door of the cooling unit.
- ☞ Remove the milk hose adapter from the milk container cover.
- ☞ Pull out the milk container.
- ☞ Lift off the milk container cover.
- ☞ Rinse the milk container, riser tube and cover with fresh water.
- ☞ Fill with milk and observe the maximum fill quantity.
The milk must not touch the milk container cover.
- ☞ Close the milk container with the milk container cover.
- ☞ Insert the milk container into the cooling unit.
- ☞ Insert the milk hose adapter into the milk container cover.
- ☞ Close the door of the cooling unit.
- ☞ Regularly check if the cooling temperature is between 3 – 5 °C (37.4 – 41 °F).

See also

- ☞ Display-guided cleaning [▶ 122]

9.1.5 Filling the Flavour Point or changing bottles

The Flavour Point is an equipment variant installed at the factory.

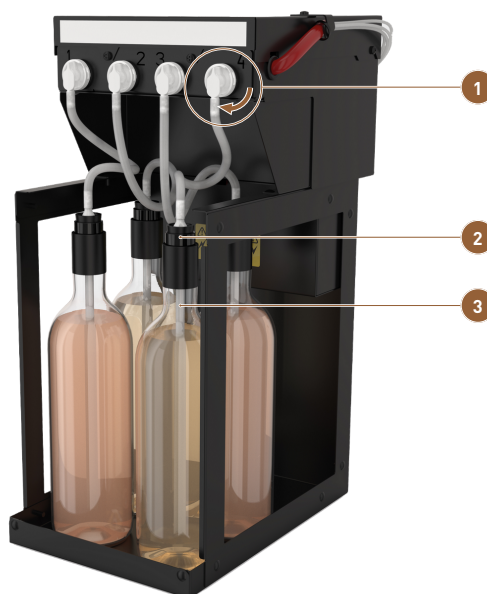

Fig. 60: Filling Flavour Point

- | | |
|--|----------------|
| 1 Hose adapter (Plug & Clean adapter) | 2 Plugs |
|--|----------------|

3 Hose

- ☞ Return the syrup bottles to the Flavour Point.
- ☞ Remove the bottle cap and insert the hose with stopper into the bottle.
- ☞ Firmly press the plug into the bottle.
- ☞ Insert the hose adapter (Plug & Clean adapter) into the Flavour Point and lock the bayonet lock by turning it to the right.
- ☞ Repeat the above steps for all syrup bottles.

After connecting the syrup bottles, the syrup hose must be filled. The **Ingredient management** routine in the Service menu is used for this purpose.

See also

📖 Functions in the Service menu [▶ 105]

9.1.6 Opening and closing the operating unit



⚠ CAUTION

Danger of crushing by falling operating unit!

The operating unit can fall down under its own weight.

- ☞ Hold the operating unit firmly and move it up or down in a controlled manner until it clicks into place.

The machine is only ready for use when the operating unit is closed.



Fig. 61: Opening operating unit

- | | |
|---------------------------------------|---------------------------------|
| 1 Lock engaged | 2 Lock disengaged |
| 3 Top side of operating unit unlocked | 4 Operating unit pushed upwards |

Opening operating unit

- ☞ Move the key in the closing device to the horizontal position.
 - ✓ The lock is open.
- ☞ Unlock the operating unit at the top by pulling firmly.
 - ✓ The operating unit is unlocked.
- ☞ Push the operating unit upwards from below with both hands as far as it will go.
 - ✓ The operating unit is automatically held in the upper position.
 - ✓ All operating elements behind the operating unit are now accessible.



Fig. 62: Operating unit closed and opened

Close operating unit

- ☑ The closing device of the operating unit can only be closed if the locking mechanisms of the bean hoppers and powder containers are closed.
- ☞ Using both hands, gently push the open operating unit down as far as it will go.
- ☞ Press the operating unit in lightly at the top edge.
 - ✓ The operating unit is closed.
- ☞ If necessary, lock the closing device again with the key.
 - ✓ The lock is closed in the vertical position.
 - ✓ The operating unit is locked.

9.1.7 Removing bean hoppers and powder containers



⚠ WARNING

Risk of crushing and cutting injuries from rotating grinding discs!



There is danger of crushing and cutting injuries due to rotating grinding discs in the grinder.

- ☞ Never reach into the bean hopper when the machine is switched on.
- ☞ Switch off the machine and disconnect the power plug before performing any work on the grinder.



⚠ CAUTION

Risk of injury from hair being drawn in



Very long hair could get stuck in the grinder head and get pulled into the machine.

- ☞ Always wear a hair net when exposing the grinder head.

Bean hoppers or powder containers can be removed from the machine. The central locking mechanism unlocks the bean hoppers and powder containers together.

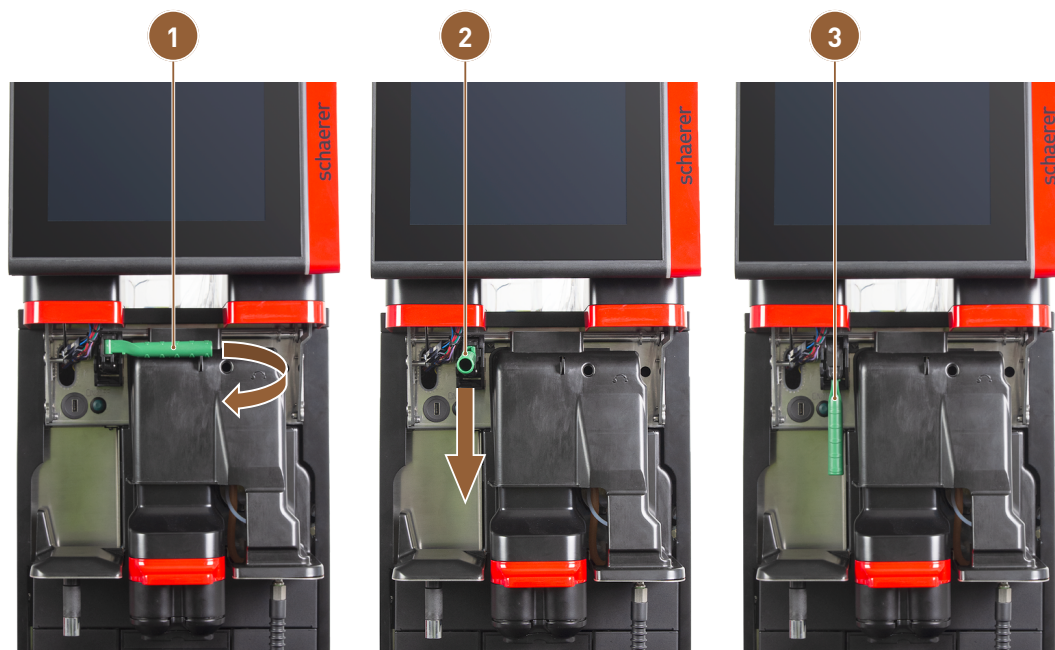

Fig. 63: Unlocking bean hoppers and powder containers

- | | |
|---|--------------------------|
| 1 Handle horizontal: Bean hopper locked | 2 Handle forwards |
| 3 Handle downwards: Bean hopper unlocked | |

- ☞ Open the user panel.
- ☞ Swivel the green handle of the central locking mechanism forward from the horizontal folded position.
- ☞ Fold the green handle of the central locking mechanism downwards.
- ✓ The bean hoppers and powder containers are now unlocked and can be removed.
- ✓ The green handle of the central locking mechanism points downwards.

See also

- 📄 Opening and closing the operating unit [▶ 70]

9.1.8 Inserting or changing ProCare cleaning bag

One ProCare cleaning pouch can be used for approx. 100 cleanings. Empty cleaning pouches must then be replaced.

The cleaning pouches are filled with cleaning powder and sealed. The blue cleaning pouch contains an alkaline-based cleaning product, the red pouch contains an acid-based cleaning product.



Fig. 64: Pulling out drawer with collecting tray

- ☞ Open the cam lock and pull out the drawer with the collecting tray and the cleaning pouches. The cam lock is located under the milk connection flap (Plug & Clean).



Fig. 65: Removing cleaning pouches

1 Cap nuts

2 Removal direction

- ☞ Loosen the cap nuts from the cleaning pouches.
- ☞ Remove and dispose of the empty cleaning pouches.
- ☞ Remove the sealing caps and the protective film from the new ProCare cleaning pouches.
- ☞ Place the new ProCare cleaning pouches on the free coupling nozzles and tighten the sealing caps of the cleaning pouches with the cap nuts. The couplings are different sizes. That means the cleaning pouches can not be interchanged.



Fig. 66: Inserting drawer

- ☞ Slide the drawer back into the housing and close the ProCare.
 - ✓ A dialog with the message **ProCare: Cleaning pouch inserted** opens.
- ☞ Confirm with **OK**.
 - ✓ The screen for conditioning the inserted cleaning pouch opens.

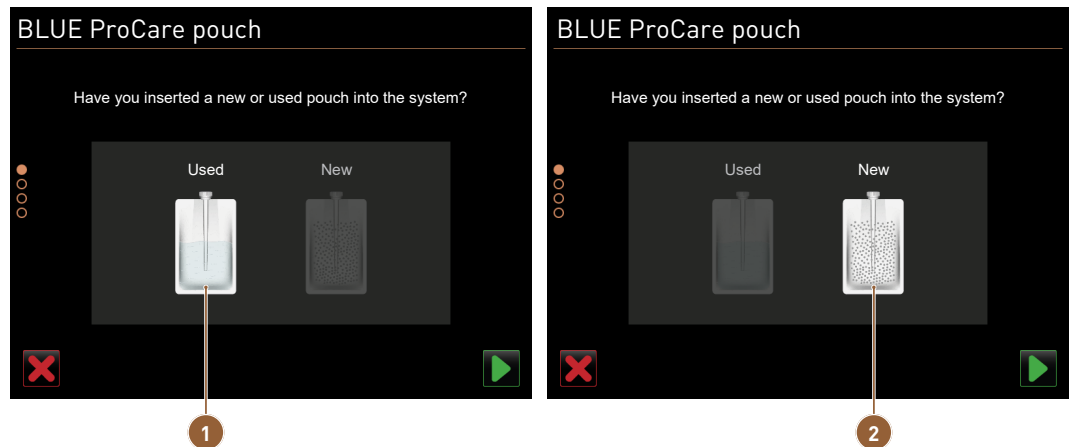

Fig. 67: ProCare BLUE example: changing cleaning pouch

- | | |
|--|--|
| <p>1 Used cleaning pouch: Air is extracted.</p> | <p>2 New cleaning pouch: Is filled with water, then the air is extracted.</p> |
|--|--|

- ☞ Tap on **Used** if you have inserted a used cleaning pouch or on **New** if you have inserted a new cleaning pouch.
- ☞ Confirm your selection with **▶**.
 - ✓ The air is now extracted from a used cleaning pouch. A new cleaning pouch is filled with water and the air is then extracted.
 - ✓ A confirmation dialog with the message **ProCare: Pouch exchange successful** opens.
- ☞ Confirm with **▶**.
 - ✓ The cleaning pouch(es) has (have) been inserted and conditioned. The ProCare is ready for cleaning processes.

The same process can be initiated manually in the Service menu.

To change the pouch with the Service menu:

- ☞ Open the Service menu with

- ☞ Tap on the **Maintenance intervals** button.



	Last done	Due
☺ Descaling	06/24/2025	In 5 months 608 liters
☺ Maintenance 2	12/03/2024	After 39978 coffee beverages
☺ Maint. 24 months	12/03/2024	In 17 months
☺ ProCare: RED pouch	07/23/2025	100 % remaining
☺ ProCare: BLUE pouch	07/23/2025	100 % remaining

Fig. 68: Display of the remaining content

- ☞ In the **Maintenance intervals** screen, tap on the  button for the **ProCare: pouch RED** or **ProCare: pouch BLUE** menu item.
- ☞ Change the pouch or cancel the process.
- ✓ You will be taken back to the main menu.

9.2 Enable

This chapter contains information on how to switch on the machine and any optional accessories (if available) safely and correctly.

9.2.1 Check before switching on



NOTE

Property damage due to closed water line!

The machine can be damaged if the water pump runs dry.

- ☞ Before switching on the machine, make sure that the main water valve (tap) of the water supply line is open.

- ☞ For mains water supply: Make sure that the main water valve is open.
- ☞ For drinking water tank: Make sure that the drinking water tank is filled with fresh water.
- ☞ With standard waste water outlet: Make sure that the waste water hose is laid correctly.
- ☞ For external waste water tank: Make sure that the external waste water tank is connected and empty.
- ☞ Make sure that the bean hoppers are filled.
- ☞ Make sure that the grounds container is empty and correctly inserted.
- ☞ Make sure the machine is correctly connected to the manufacturer-side power supply in accordance with national or local safety regulations.

9.2.2 Switching on machine



CAUTION

Risk of infection from contamination in the milk pump!

Contamination in the milk pump can lead to infections. Infections can trigger health problems.

- ☞ Always carry out cleaning after installation, commissioning or after recommissioning.
- ☞ Run the display-guided cleaning program before the first beverage dispensing process.

When the machine is switched on for the first time, a display-guided commissioning process is performed automatically. Commissioning must be carried out by a service technician. The service technician configures the machine and performs a hardware calibration.

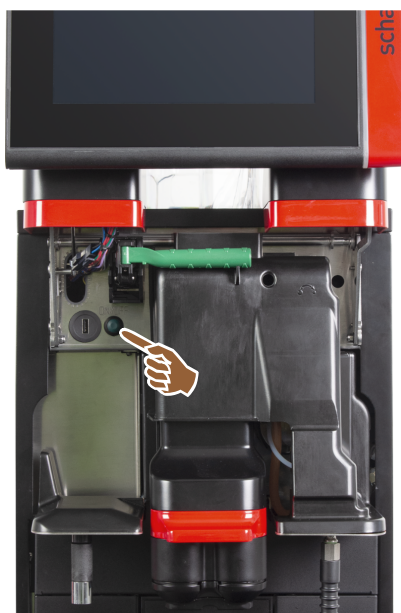

Fig. 69: Switching on machine

- ☞ Check the power connection of the machine.
- ☞ Open the user panel.
- ☞ Briefly press the On/Off button.
 - ✓ The machine starts.
 - ✓ The user interface appears on the touch screen.
 - ✓ Machine heating begins.
 - ✓ The machine is ready for use as soon as the required temperature is reached.
- ☞ Close the user panel.
- ✓ The machine is switched on.

See also

- 📖 Opening and closing the operating unit [▶ 70]

9.2.3 Switching on Flavour Point

The Flavour Point is an equipment variant.



Fig. 70: Switching on Flavour Point

- ☞ Switch toggle switch to position I.
- ✓ The **Flavour Point** syrup module is switched on.

9.2.4 Switching on optional accessories

Optional accessories are equipment variants.



Detailed information on the optional accessories can be found in the separate description with the **operating instructions for the under-machine cooling unit, cup warmer and Cup & Cool**.

Switching on side cooling unit

- ☞ Open the door of the cooling unit.
- ☞ Switch toggle switch to position I.
- ☞ Hold button  down for approx. 3 s.
- ✓ The device is switched on.
- ✓ The current interior temperature of the cooling unit is shown on the display.

Switching on under-counter cooling unit

- ☞ Open the door of the cooling unit.
- ☞ Switch toggle switch to position I.
- ☞ Set the thermostat on the back to the center position.
- ✓ The under-counter cooling unit is switched on.

Switching on under-machine cooling unit

- ☞ Open the door of the cooling unit.
- ☞ Press the on/off button in the top door rebate.
- ☞ The On/Off button lights up green.
- ☞ The cooling unit reaches the operating temperature after about 60 min.

Cup & Cool: Switching on cooling unit

- ☞ Press the On/Off button in the top right on the rear casing.

- ☞ The On/Off button lights up green.
- ✓ The cooling unit reaches the operating temperature after about 60 min.

Switching on cup warmer

The instructions also apply to the cup warmer unit in the Cup & Cool device.

- ☞ Check the power connection of the device.
- ☞ Press the On/Off button in the top left on the rear casing.
- ✓ The On/Off button lights up green.
- ✓ The cup warmer heats up after approx. 60 min.

Activating cup warmer lighting



- ☞ The cup warmer is switched on.
- ☞ Use a pin with a diameter of approx. 2-3 mm to press the button for the top lighting on the rear casing for approx. 2 s.
 - ✓ The lighting is activated in a random color.
- ☞ Changing color: Briefly press the button again.
 - ✓ The color changes to another random color one time.
- ☞ Activating interval lighting: Press the button briefly several times until the lighting is switched off.
 - ✓ After 5-10 s, the interval lighting is activated and the color changes at intervals.
- ☞ Activating specific color: When the desired color lights up during the interval lighting: Press the button again.
 - ✓ The lighting is activated and the selected color lights up permanently.

See also

- ☞ Setting cooling unit temperature [▶ 78]

9.2.5 Setting cooling unit temperature

side cooling unit

- ☞ Hold button  down for approx. 3 s.
- ☞ Set the temperature 3 – 5 °C (37.4 – 41 °F) higher with button  or lower with button .
- ☞ Confirm the setting with the Set button.
- ✓ The cooling unit switches to the operating mode.
- ✓ The current interior temperature of the cooling unit is shown on the display.

Cooling unit with thermostat on the back of the device

- ☞ To reduce the operating temperature, turn the thermostat on the back of the device to the right into the blue area.
- ☞ To increase the operating temperature, turn the thermostat on the back of the device to the left into the red area.

9.3 Positioning beverage outlet



Fig. 71: Positioning beverage outlet

Positioning beverage outlet with manual beverage outlet

☞ Guide the beverage outlet up to the cup using the handle.

Positioning beverage outlet with automatic height-adjustable beverage outlet

The AHA (automatic height-adjustable beverage outlet) automatically adjusts to the correct outlet height corresponding to the previously selected beverage.

9.4 Operating modes

The user interface of the machine can be set to one of the following operating modes by service technicians:

- Guest mode
- Staff mode
- Frequent user mode

9.4.1 Functions of the operating modes

The user interfaces in the various operating modes (**Guest mode**, **Staff mode** and **Frequent user mode**) have different functions and messages.

The following table provides an overview of the active functions and displays in the default setting.

Function	Guest mode	Staff mode	Frequent user mode
Display of notification mode	Simple	Specific	Specific
Double button visible	Cannot be activated	ON (can be deactivated)	Cannot be activated
DECAF button visible	Cannot be activated	ON (can be deactivated)	Cannot be activated
Barista button visible	Cannot be activated	Can be activated	ON (can be deactivated)
Cup size button visible	Cannot be activated	Cannot be activated	Cannot be activated
Cup icons visible	ON (cannot be deactivated)	ON (cannot be deactivated)	ON (cannot be deactivated)

Function	Guest mode	Staff mode	Frequent user mode
Icon sets	Paper cups (can be activated)	Default (can be activated)	Paper cups (can be activated)
Screen saver	ON (can be deactivated)	Can be activated	ON (can be deactivated)
Beverage groups	Customized	Customized	Customized
Activate beverage preselection	Cannot be activated	ON (can be deactivated)	Cannot be activated
Enable preselection on touch screen	Cannot be activated	ON (can be deactivated)	Cannot be activated
Number of positions in the preselection	Cannot be activated	0 – 8 (8)	Cannot be activated
Enable preselection on external buttons	Cannot be activated	Cannot be activated	Cannot be activated
Beverage preselection section left	Cannot be activated	ON (can be deactivated)	Cannot be activated
Beverage preselection section right	Cannot be activated	ON (can be deactivated)	Cannot be activated
Warm-up rinsing button visible	Cannot be activated	Cannot be activated	Cannot be activated
Service button visible	ON (can be deactivated)	ON (can be deactivated)	ON (can be deactivated)
Show group selection	Can be activated	Cannot be activated	Can be activated
Sequential beverage modification	ON (cannot be deactivated)	Cannot be activated	Cannot be activated
Display position cup	Can be activated	Can be activated	ON
Display progress	ON (cannot be deactivated)	Can be activated	ON (cannot be deactivated)
Display beverage complete	ON (can be deactivated)	Can be activated	Can be activated
Display beverage complete interruption	0.5 – 60 s (3 s)	0.5 – 60 s (3 s)	0.5 – 60 s (3 s)
Access to Service menu	PIN (can be activated)	PIN (can be activated)	PIN (can be activated)

9.4.2 Guest mode

The preconfigured **Guest mode** user interface supports operation of the machine by guests without any knowledge of the machine.

Guest mode is the operating mode with the smallest range of functions. Service technicians can also make individual settings.

Display of beverages

The available beverages are displayed horizontally next to each other. If beverage groups are configured, they are displayed.

Menu navigation

The beverage options are selected step by step on successive screens. 1 beverage option can be selected per screen. The coffee strength cannot be modified.

In Guest mode, the pre-selection options before beverage supply (double beverage, decaffeinated coffee, coffee strength), steam dispensing and the direct selection buttons are not available.

Maximum configurable number of groups and beverages

- 10 beverage groups
- 24 beverages per beverage group
- 240 beverages

Functions in Guest mode

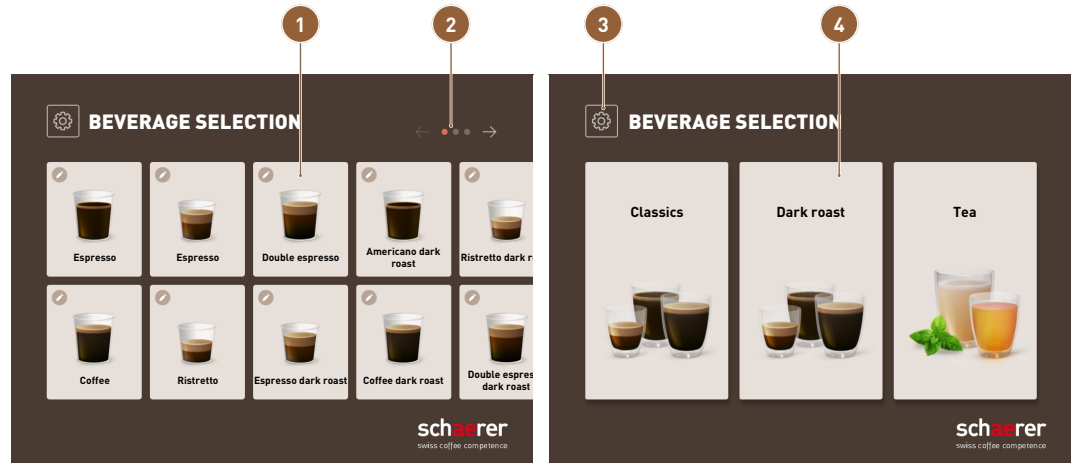

Fig. 72: Functions in Guest mode

- | | |
|--|---|
| <p>1 Display of a maximum of 240 beverages (10 groups with a maximum of 24 beverages each)</p> <p>3 Access to Service menu</p> | <p>2 Navigation through beverage groups (arrow)</p> <p>4 Beverage selection via beverage groups</p> |
|--|---|

Steps up to beverage dispensing

- Select desired beverage
- Define cup/mug size
- Select coffee roast (optional)
- Confirm selection
- Payment (with payment system, option)
- Instruction to position cup/mug
- Start dispensing
- Fill ground coffee (with separate manual inlet)
- Confirm manual inlet
- Beverage is dispensed
- Display of progress of beverage dispensing
- Beverage complete display

Configurable options

Service technicians can extend or reduce the standard configuration with the following additional functions:

- Screensaver on/off
- Service menu button visible/not visible
- Beverage groups visible/not visible
- Instruction for positioning cup/mug on/off
- Display/Do not display Beverage complete information

9.4.3 Staff mode

The preconfigured **Staff mode** user interface supports operation of the machine by operating staff with machine knowledge. Beverages are selected exclusively by qualified staff.

Staff mode is the operating mode with the widest range of functions. Service technicians can make individual settings.

Display of beverages

The available beverage groups are displayed as horizontal tabs. The available beverages are displayed on each beverage group.

It is possible to pre-select beverages (double beverages, decaffeinated coffee, coffee strength/barista function) in Staff mode. The pre-selection options are displayed in a vertical menu on the left.

Up to 5 buttons can be configured at the bottom edge for direct selection of a beverage with autostart or for steam dispensing.

Menu navigation

The modification of the beverages is displayed and performed in full on the Dispense beverages screen. Autostart can be configured for predefined beverages using direct selection buttons.

Maximum configurable number of groups and beverages

- 10 beverage groups
- 24 beverages per beverage group
- 240 beverages

Functions in Staff mode



Fig. 73: Functions in Staff mode

- | | |
|--|--|
| <p>1 Selection of beverage groups using tabs</p> <p>3 Screen for selection of beverage options</p> <p>5 Display of a maximum of 240 beverages (10 groups with a maximum of 24 beverages each)</p> <p>7 Barista pre-selection (coffee strength)</p> <p>9 Double beverage pre-selection</p> | <p>2 Swipe function (finger) for scrolling through the available beverages</p> <p>4 Direct selection buttons in the right-hand side menu</p> <p>6 Direct selection buttons on the left on the lower edge of the screen</p> <p>8 Decaffeinated coffee pre-selection</p> <p>10 Access to Service menu</p> |
|--|--|

Steps up to beverage dispensing

- Preselection (e.g. DECAF or double beverage)
- Preselection of coffee strength (barista)
- Select desired beverage
- Define beverage options
- Payment (with payment system, option)
- Start dispensing

- Fill ground coffee (with separate manual inlet)
- Confirm manual inlet
- Beverage is dispensed
- Display of progress of beverage dispensing

Configurable options

Service technicians can extend or reduce the standard configuration with the following additional functions:

- Button for double beverage on/off
- Button for decaffeinated coffee (DECAF) on/off
- Button for coffee strength (barista function) on/off
- Beverage pre-selection (multiple dispensing) on/off
- Display of number of pre-selected beverages on/off
- Service menu button visible/not visible
- Instruction for positioning cup/mug on/off
- Display/Do not display progress information
- Display/Do not display Beverage complete information

9.4.4 Frequent user mode

The preconfigured **Frequent user mode** user interface allows for operation of the machine by advanced operators (e.g. in office areas).

Frequent user mode is the operating mode with a middle range of functions. Service technicians can also make individual settings.

Display of beverages

The available beverages are displayed horizontally next to each other. If beverage groups are configured, they are displayed.

Up to 3 buttons can be configured at the bottom edge for direct selection of a beverage with autostart.

In Frequent user mode, the pre-selection options before beverage supply (double beverage, decaffeinated coffee, coffee strength) and steam dispensing are not available.

Menu navigation

The modification of the beverages is displayed and performed in full on the Dispense beverages screen. In Frequent user mode, the coffee strength can be modified. Autostart can be configured for predefined beverages using direct selection buttons.

Maximum configurable number of groups and beverages

- 10 beverage groups
- 24 beverages per beverage group
- 240 beverages

Functions in Frequent user mode

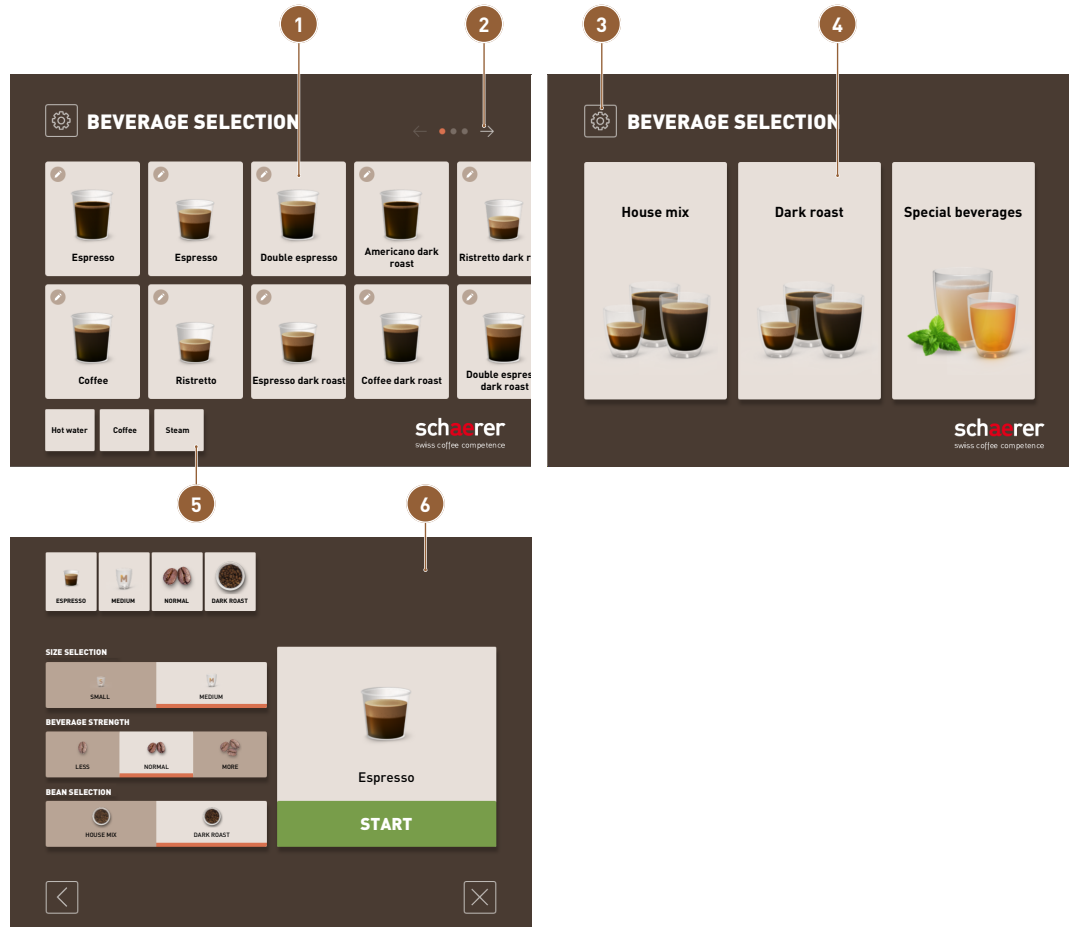

Fig. 74: Functions in Frequent user mode

- | | |
|--|--|
| <p>1 Display of a maximum of 240 beverages (10 groups with a maximum of 24 beverages each)</p> <p>3 Access to Service menu</p> <p>5 Maximum of 3 additional beverage buttons for direct selection</p> | <p>2 Navigation through beverage groups (arrow)</p> <p>4 Beverage selection via beverage groups</p> <p>6 Screen for selection of beverage options</p> |
|--|--|

Steps up to beverage dispensing

- Select desired beverage
- Define cup/mug size
- Select coffee roast (optional)
- Confirm selection
- Payment (with payment system, option)
- Instruction to position cup/mug
- Start dispensing
- Fill ground coffee (with separate manual inlet)
- Confirm manual inlet
- Beverage dispensing is performed.

Configurable options

Service technicians can extend or reduce the standard configuration with the following additional functions:

- Buttons for coffee strength on/off
- Screensaver on/off
- Service menu button visible/not visible
- Beverage groups visible/not visible
- Instruction for positioning cup/mug on/off
- Display/Do not display Beverage complete information

9.5 Beverage supply

Limited beverage selection

Machines with an external drinking water tank are limited in their beverage selection. It is not possible to dispense cooled beverages with an external drinking water tank.

Powder beverages are always dispensed hot with an external drinking water tank, regardless of the set temperature.

Cancellation of beverage selection after inactivity

Beverage selection can be automatically canceled after 5 – 40 s of inactivity. In this case, the user interface is displayed for a new beverage selection process.

The time period can be adjusted by service technicians in the **Configuration > Operating mode > Reset selection time-out** settings.

9.5.1 Selecting beverage



Fig. 75: Guest and Frequent user mode: Scrolling to beverage

Guest and Frequent user mode: Navigating to beverage

- ☰ The machine is ready for use.
- ➡ Use the arrow buttons to scroll through the beverage displays.
- ✓ The desired beverage button appears.



Fig. 76: Staff mode: Direction selection of beverage group

Staff mode: Navigating to beverage

- ☰ The machine is ready for use.
- ☞ Open the desired beverage group directly via the corresponding tab.
- ✓ The saved beverage buttons appear.

Staff mode: Pre-selecting beverage options

Possible pre-selections in the menu:

- Double beverage dispensing
- Decaffeinated coffee
- Coffee strength (barista)



Fig. 77: Beverage preselection in the left menu

- ☰ The user interface is in Staff mode.
- ☞ Select a beverage option via a preselection in the left menu, e.g. coffee strength.
- ✓ All beverages with the corresponding option appear.



Fig. 78: Beverage types

Staff mode: Selecting beverage type

- ☰ The tab with the beverage group or the pre-selection contains configured beverages.
- ☞ Tap on the desired beverage button.
- ✓ A screen with more beverage options opens.

9.5.2 Modifying beverage

Possible beverage options:

- Beverage type (e.g. coffee, espresso, cappuccino)
- Beverage size (S, M, L)
- Coffee type (2-3 grinds)
- Milk type (Twin Milk)
- Chocolate (with powder system)
- Aroma (with Flavour Point syrup system)

The pre-selection of ingredients and beverage size can be set and activated by service technicians in the beverage configuration.

The beverage is modified differently depending on the operating mode:

- Sequential beverage modification (Guest mode): Each beverage option is displayed on a separate screen.
- Direct beverage modification (Staff mode and Frequent user mode): All beverage options are displayed together on one screen.

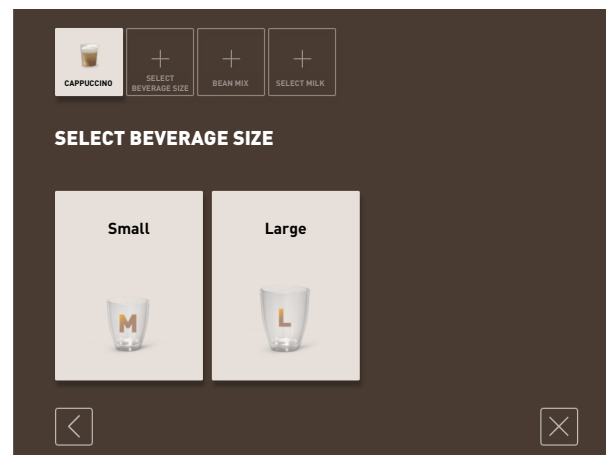



Fig. 79: Guest mode: Determining beverage modification sequentially

- ☰ The selected beverage is marked as modifiable with the pencil icon .
- ☞ Tap on the button with the desired modification.

- ✓ The desired modification appears.
 - ✓ Additional modifications are displayed for selection.
- ☞ Select the additional modifications.

Sequential beverage modification

Sequential beverage modification is active in Guest mode and cannot be deactivated.

Sequential beverage modification asks for a pre-selection of beverage options step by step. The options are each offered for selection in a separate display.

Progress display for sequential beverage modification

Prerequisite:

- The beverage is configured for dispensing with different ingredients.
- The **Beverage selection progress** type of display is available in Guest mode.

The progress display provides information about the beverage options already selected and those still to be selected.

Each selected ingredient is displayed by a icon.

Each step still to be selected is shown with an empty display field.

The **Beverage selection progress** display cannot be deactivated.



Fig. 80: Selection of beverage

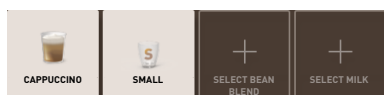

Fig. 81: Selection of beverage size

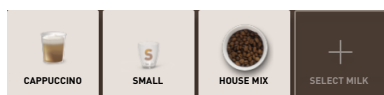

Fig. 82: Selection of coffee type

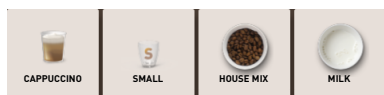

Fig. 83: Selection of ingredients

Direct beverage modification

Direct beverage modification is active in Staff mode and in Frequent user mode and cannot be deactivated.

With this function, the selection of beverage options is offered directly in the same display.



Fig. 84: Direct beverage modification in Staff mode

1 Buttons for beverage modification

2 Button for multiple dispensing



Fig. 85: Direct beverage modification in Frequent user mode

1 Display: Summary of beverage modification

2 Buttons for beverage modification

3 Variant: Button for navigating to additional beverage modifications

- ☞ Tap on the button with the desired modification.
- ☞ If necessary, set multiple dispensing (1 to 9 beverages).
 - ✓ The selected modifications are active.
- ☞ Tap on the button with the desired modification.
 - ✓ The selected modifications are summarized in the upper area.

9.5.3 Double beverage pre-selection

Double beverages can be dispensed in Staff mode. This allows two cups to be filled at the same time, with the respective quantity per cup being dispensed once on the left-hand side and once on the right-hand side of the beverage outlet.

The preselection option for double beverages can be set by service technicians in the beverage configuration.

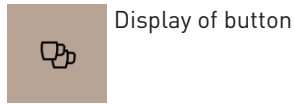

Display of button

Starting preselection

Prerequisite:

- The double button visible function is activated in Staff mode.
- Beverages with double dispensing have been configured.
- ☞ Tap on the Double beverage dispensing button.
- ✓ All beverages that are configured for double beverage dispensing are actively displayed for selection in the user interface.

9.5.4 Dispensing pre-selected beverages multiple times

Preselection for multiple beverages is only available in Staff mode.

The function is available if the parameter is activated in the **Configuration > Operating mode > Activate preselection via touch screen** setting.

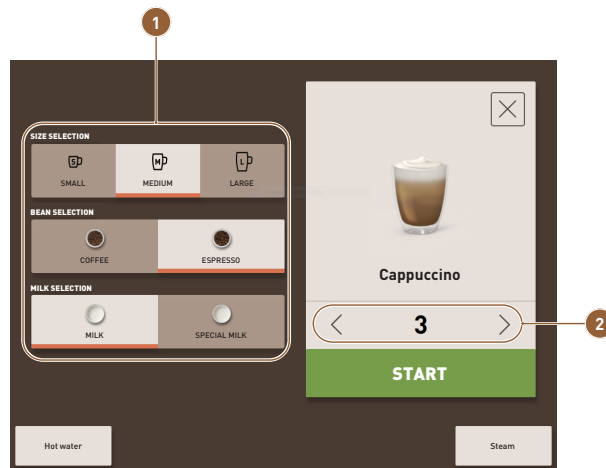

Fig. 86: Beverage modification screen

1 Buttons for beverage modification

2 Button for multiple dispensing

- ☞ The pre-selection is activated in operating mode (maximum 1 – 9 beverages).
- ☞ Select a beverage.
- ☞ Select the desired ingredients.
- ☞ Set the number of beverages using the arrow buttons < 1 – 9 >.
 - ✓ The beverage dispensing process is repeated a maximum of nine times.
 - ✓ The progress of all dispensing processes is displayed.

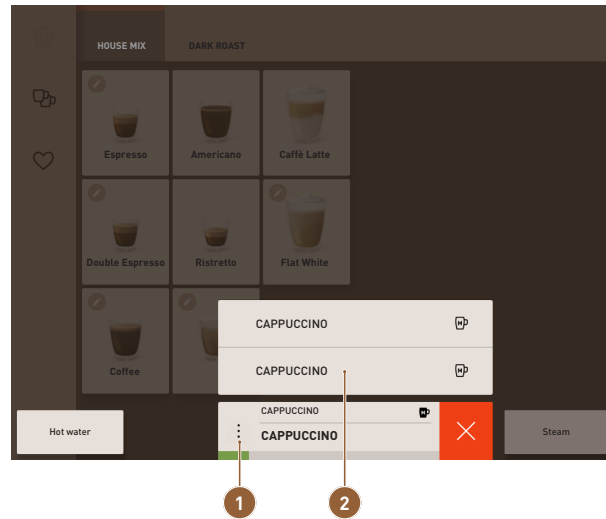

Fig. 87: Screen showing list of preselected beverages [Staff mode with milk]

1 Three-dot menu

2 List with pre-selected beverages

- ☞ Tap on the three-dot menu.
 - ✓ A list with the pre-selected beverages appears.
 - ✓ When beverage dispensing is complete, this is displayed in green.
- ☞ Remove the cup or mug from the beverage outlet.

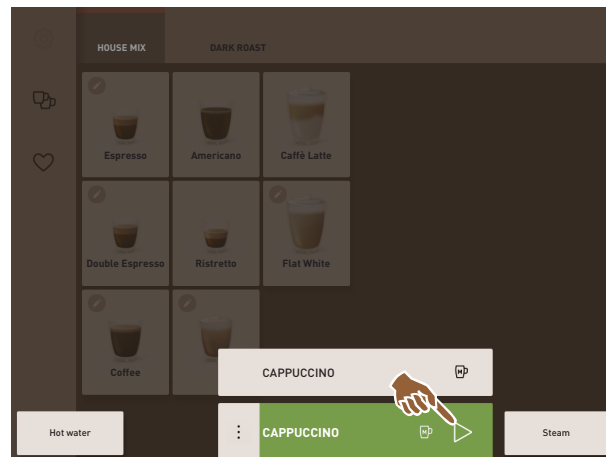

Fig. 88: Dispensing additional beverage

- ☞ Tap on the Play button.
 - ✓ The first beverage is confirmed.
 - ✓ Dispensing of the next beverage from the list starts.
- ☞ Repeat the previous step for additional beverages.

9.5.5 Decaffeinated coffee pre-selection

In Staff mode, decaffeinated coffee can be pre-selected directly. This means that only beverages for which a variant with decaffeinated coffee is available are displayed as active.

The **Decaffeinated coffee** pre-selection can be set by service technicians in the beverage configuration.

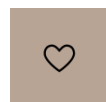

Display of button

Starting preselection

Prerequisite:

- The **DECAF** button visible function is activated in Staff mode.
- The machine is equipped with two bean hoppers, one of which is filled with decaffeinated beans.
- Alternatively, the machine can be filled with decaffeinated ground coffee through the manual inlet.

Variant with second grinder

☞ Tap on the Without caffeine button.

- ✓ Only the beverages that have been configured with decaffeinated coffee beans are available for selection.

Variant with ground coffee and manual inlet

☞ Tap on the Without caffeine button.

- ✓ Only the beverages that have been configured as a source with DECAF are available for selection.
- ✓ During dispensing, you will be instructed to add the decaffeinated ground coffee.

9.5.6 Barista preselection

In Staff mode, the strength of the beverage to be dispensed can be influenced once using the **Barista** function.

Three settings are available: **Mild, medium and strong.**

After the beverage has been dispensed, the barista field returns to the standard setting of **medium.**

The Barista preselection can be activated in Staff mode by service technicians.

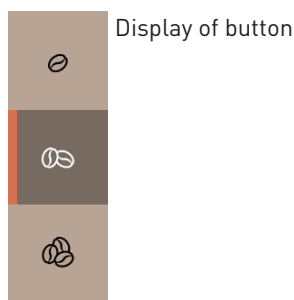

Starting preselection

Prerequisite:

- The **Barista** function is available for activation in Staff mode.
- The beverage has been configured with the **Barista** function.
- ☞ Tap on the button with the desired coffee strength.
- ✓ Only those beverages whose strength can be adjusted are available for selection.

9.5.7 Positioning cup/mug

During beverage dispensing, an instruction to position the cup or mug appears.

The **Position cup** instruction can be activated in the operating mode by service technicians.

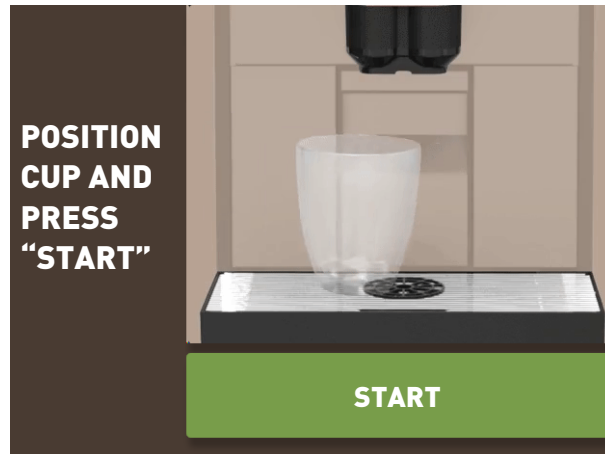

Fig. 89: Positioning cup/mug animation is shown in the display.

- ☰ The **Position cup** function is activated in the operating mode.
- ☞ Place the cup or mug under the beverage outlet.
- ☞ For manual beverage outlet: Pull the beverage outlet down onto the cup or mug.

9.5.8 Paying for beverage

Prerequisite: A payment system is activated and the beverage contains a beverage price.

If a payment system is activated, an instruction for payment appears first.

The selected beverage options are confirmed with the **PAY** button. The payment process is then started.

Once the payment process has been completed, the **PAY** button changes to the **START** button.

The **START** button starts the beverage dispensing process.

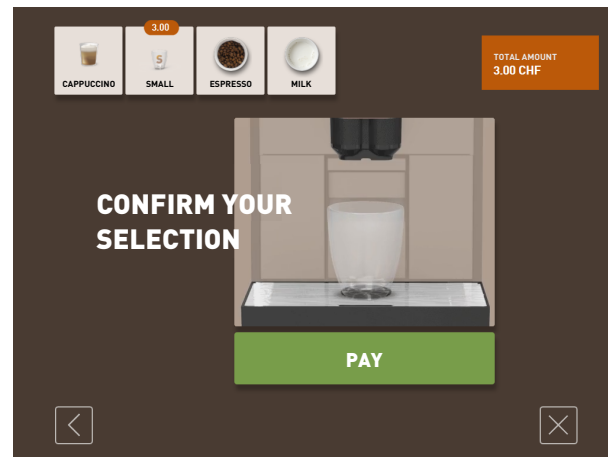

Fig. 90: Button for payment

- ☞ Tap on the **Pay** button.
 - ✓ The screen with the payment methods offered appears.
 - ✓ If coin change systems are used, they display if it is no longer possible to change coins.

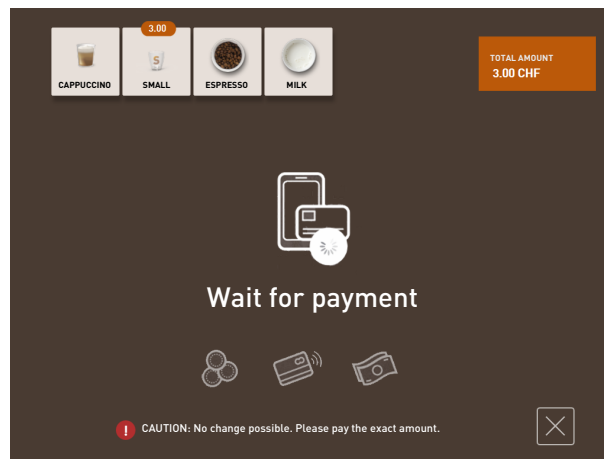

Fig. 91: Instruction for payment

- ☞ Select an available payment method.
- ☞ Confirm the payment process and complete the payment process.
- ✓ Beverage dispensing starts.

9.5.9 Dispensing beverage

Variant: Dispensing without payment system

Once beverage pre-selection is complete, the **START** button appears.

The **START** button confirms the selected beverage options and starts the beverage dispensing process.

The **Position cup** instruction can be activated or deactivated by service technicians in the configuration for the respective operating mode.

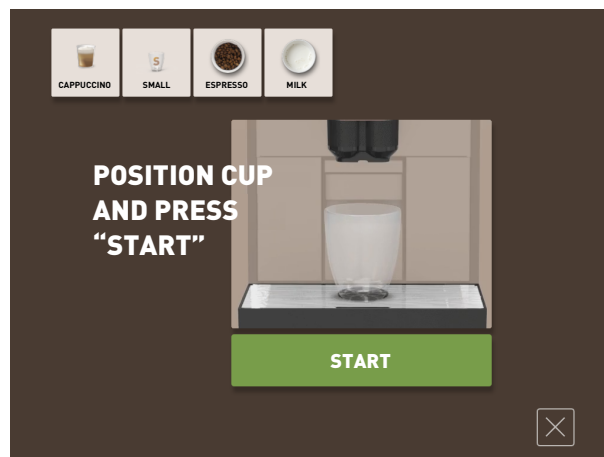

Fig. 92: Beverage ready for dispensing

- ☰ The beverage has been modified and is ready for dispensing.
- ☞ Tap on the **START** button.
 - ✓ The **Position cup** instruction appears.
- ☞ Tap on the **START** button again.
- ✓ The beverage is dispensed.

9.5.10 Progress display for beverage dispensing

Prerequisite for all variants: Beverage dispensing starts.

Variant: Guest/Frequent user mode



Fig. 93: Guest and Frequent user mode: Canceling beverage dispensing

Guest and Frequent user mode: Progress screen

- The progress is displayed as a green bar in a semicircle. The dynamic green bar runs around the digital manometer in a semicircle from left to right.
- The digital manometer provides information about the current water pressure during a coffee brewing cycle.
- The progress display provides information about the remaining dispensing time during beverage dispensing.
- The progress display can be activated in the operating mode.

Variant: Staff mode

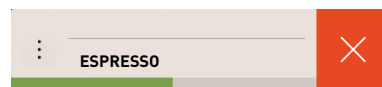

Fig. 94: Progress (Staff mode)

Staff mode: Progress screen

- The progress is displayed as a green bar.
- The dynamic green bar runs horizontally from left to right.
- The progress display with bar can be activated in the operating mode.

9.5.11 Completion of beverage

The display informs you when dispensing is complete.

- ▣ The information appears if the parameter is activated in the **Configuration > Operating mode** setting.

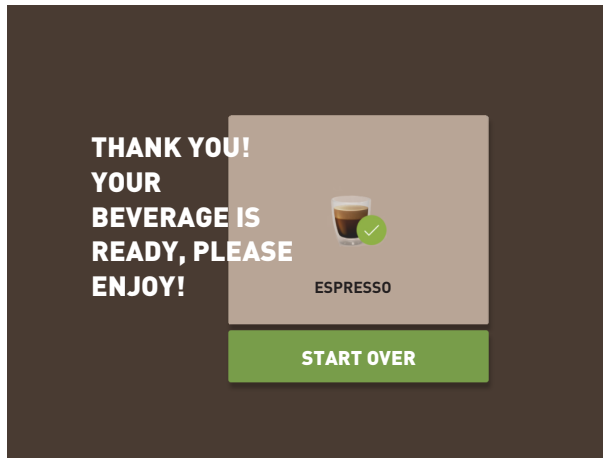

Fig. 95: Display of Beverage dispensing completed

- ☞ Remove the cup or mug from the drip tray.
- ✓ The Remove cup/mug animation is shown in the display.

9.5.12 Canceling beverage dispensing

Canceling before beverage dispensing

The button cancels the pending beverage dispensing process and takes you back to the beverage selection screen.

The button appears while beverage options are being selected. The current selection and any pre-selected beverage options are then canceled before the beverage is dispensed.

Canceling during beverage dispensing

The **CANCEL** button appears during beverage dispensing.

The **CANCEL** button cancels the beverage dispensing process. Pre-selected beverages are also deleted.

Guest mode and Frequent user mode: cancel beverage dispensing

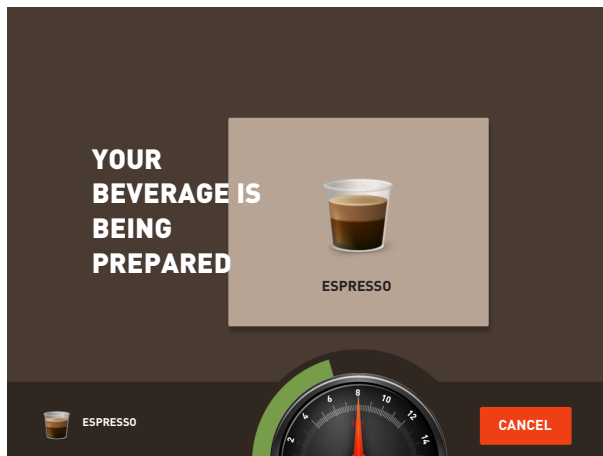

Fig. 96: Guest mode and Frequent user mode: canceling beverage dispensing

- ☞ Tap on the **CANCEL** button.
- ✓ Beverage dispensing is canceled.

Staff mode: cancel beverage dispensing

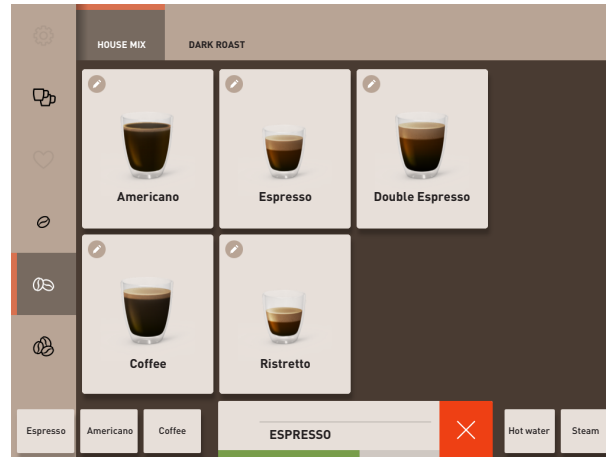

Fig. 97: Staff mode: canceling beverage dispensing

- ☞ Tap on the X button.
- ✓ Beverage dispensing is canceled.

9.6 Dispensing steam



WARNING

Risk of infection from contamination of the steam wand!



Contamination can lead to infections. Infections can trigger health problems.

- ☞ Wipe the steam wand with a clean, damp cloth after each use.
- ☞ Wear protective gloves while cleaning.

- ☞ Pull the steam wand a bit to the front.
- ☞ Place a small mug on the drip grid under the steam wand.
- ☞ Make sure that the tip of the steam wand is completely immersed in the beverage.
- ☞ Press the **Steam** button on the screen.
 - ✓ Steam is dispensed into the beverage.
 - ✓ With the **Autosteam** or **Supersteam** option: Steam dispensing stops automatically.
- ☞ With the **Powersteam** option: Press the Steam button on the screen to stop.
- ☞ Make sure that steam dispensing has ended.
- ☞ Pull the steam wand a bit to the front using the lever and remove the mug at the same time.
- ☞ Point the steam wand downwards towards the drip grid with the lever.
- ☞ Press the **Steam** button and allow steam to escape for approx. 2 s.
 - ✓ Milk residues in the steam wand are removed.
- ☞ Wipe off the milk residue on the steam wand with a clean, damp cloth.
- ☞ Clean the steam wand regularly.

9.7 Using manual inlet



NOTE

Property damage due to unsuitable ground coffee!

Using unsuitable ground coffee in the manual inlet may damage the machine.

- ☞ Only use ground coffee for the manual inlet.
- ☞ Do not use water-soluble coffee powder.
- ☞ Do not use ground coffee that is ground too fine.

Ground coffee is available for preparing a beverage using the manual inlet.

The configuration for coffee beverages with ground coffee is available in the beverage settings. Configuration can be carried out by service technicians.

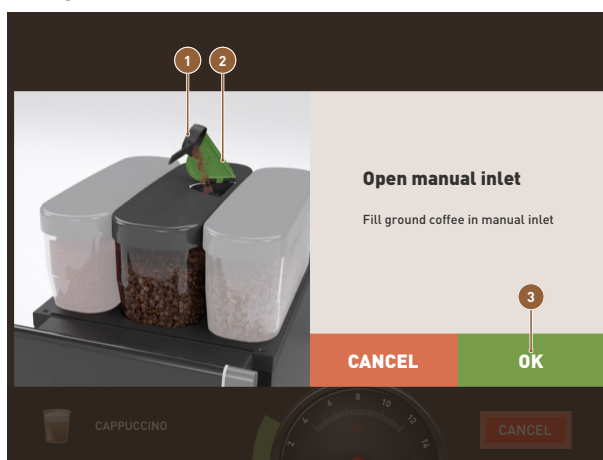

Fig. 98: Instruction for adding ground coffee

- | | |
|--------------------------------|--------------------------|
| 1 Spoon with ground coffee | 2 Manual inlet flap open |
| 3 Confirmation after insertion | |

- ☞ Select a beverage group with beverage options on the user interface.
- ☞ Select a beverage with the option for pre-ground coffee, e.g. decaf.
- ☞ If necessary, select the other dispensing options, such as small, medium or large.
- ☞ Start the dispensing process.
 - ✓ An animation instructing you to insert ground coffee appears.
- ☞ Open the cover of the manual inlet.
- ☞ Pour a portion of ground coffee into the opening of the manual inlet using the measuring spoon provided.
- ☞ Confirm this with **OK**.
- ✓ Beverage dispensing starts.

9.8 Generic functions of the user interface

This chapter contains information about general functions of the user interface. Knowledge of the functions is essential for daily operation of the machine.

9.8.1 Navigation in the interface

Guest and Frequent user mode

In **Guest mode** and **Frequent user mode**, you can navigate by **swiping** left or right across the screen. You can also use the arrow buttons to **scroll** through all beverage groups.



Fig. 99: Navigation in Guest mode with arrow buttons

- The arrow < button navigates to the left to the previous beverage group.
- The arrow > button navigates to the right to the next beverage group.

The number of dots corresponds to the number of beverage groups available.

Staff mode

In **Staff mode**, you navigate by **swiping** across the beverage groups at the top of the screen.

- Tapping on a tab directly selects a beverage group.
- Swiping to the left or right on the tabs navigates to the previous or next beverage group.



If the number of tabs (beverage groups) is not fully visible:

Back button



Next button



The  button takes you back to the previous screen. The  button takes you to the next screen.

9.8.2 Display of beverages

Type of display

The type of display for the beverages on the user interface depends on the operating mode.

The beverage buttons can be individually named and assigned via media packages at the request of the customer.

The configuration of the display is carried out by service technicians.

Each beverage button can be individually assigned a beverage. The beverage button starts the corresponding beverage dispensing process or pre-selection for additional ingredients and beverage options.

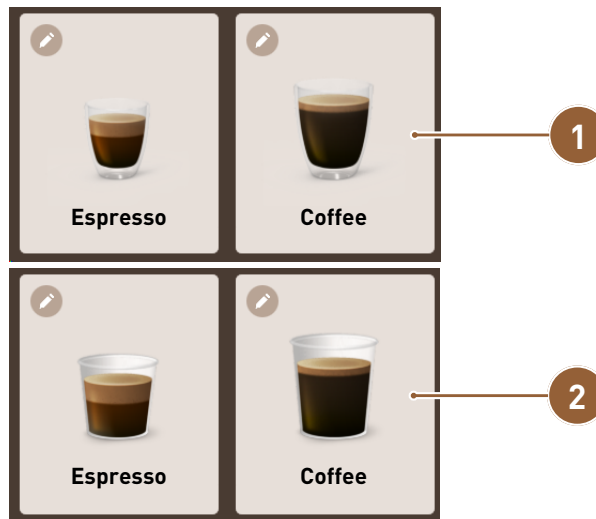

Fig. 100: Types of display of the beverage buttons

1 Display with glass (standard)

2 Display with cup (optional)

Size of display

The display size of the beverages is defined in the Menu card configuration.

Available display sizes:

- Small
- Medium
- Large
- Extra large
- Dynamic



Fig. 101: Small and extra large beverage display

9.8.3 Pending error message or instruction for action



! CAUTION: No change possible. Please pay the exact amount.

Error messages are displayed at the top or bottom of the user interface. If an error message is active, intervention by the user or a service technician is required.

- ☞ Tap on the error message display.
 - ✓ The Service menu appears.
- ☞ Select the pending error message with the (➤) button in the Service menu.
- ☞ The **Smart info** window with additional information appears.

9.8.4 Error messages (simple)

Error messages or instructions are shown differently on the display depending on the set operating mode.

In Guest mode, the default setting for error messages is **simple**.

Service technicians can change the setting to **specific error messages**.

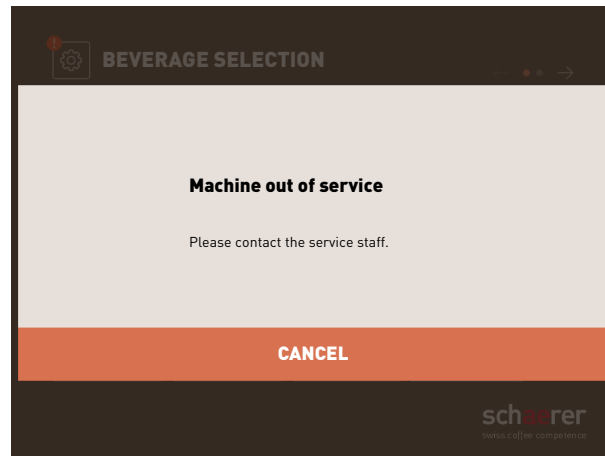

Fig. 102: Simple error message

Simple error messages show the following information:

- The machine is no longer ready for use.
- The **Inform service staff** instruction is displayed.

9.8.5 Error messages (specific)

Error messages or instructions are shown differently on the display depending on the set operating mode.

In Staff or Frequent user mode, the default setting for error messages is **specific**.

Specific error messages show the following information:

- Instructions for action or errors are displayed immediately.
- The machine can be independently restored to the ready for use condition if necessary.

Service technicians can change the setting to a **simple error message**.

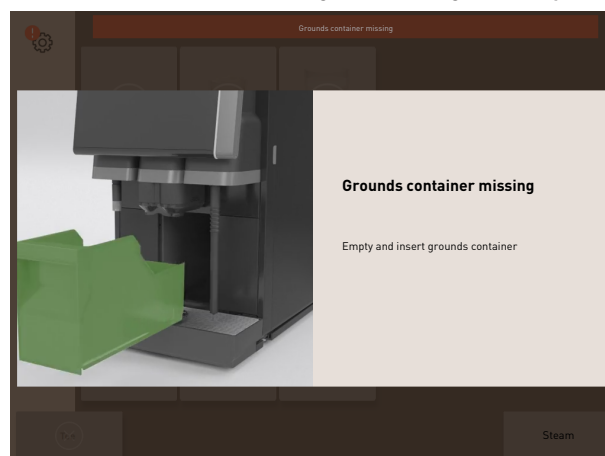

Fig. 103: Specific error message screen

9.9 Service menu

This chapter describes the functions and options of the machine Service menu.

9.9.1 Service menu button

The **Service menu** button may be displayed differently depending on the operating mode.



Service menu button in Guest mode



Service menu button in Staff mode and Frequent user mode

The Service menu button has two functions:

- Control function: The Service menu is opened with the Service menu button.
- Report function: Additional information with color marking

Control function for opening the Service menu:

☞ Tap on the **Service menu**  button.

- ✓ The Service menu opens.

Report function: Additional information with color marking

In the user interface, the Service menu button provides information about pending information or error messages.



Fig. 104: Service menu button with messages

- **Without color code:** No messages are pending in the Service menu.
- **Orange:** Information is available in the Service menu.
- **Red:** Error messages or instructions for action are pending in the Service menu.

9.9.2 Service menu overview

Overview of functions

Access to the Service menu in the **Machine operator** profile can be protected by a service technician with a PIN as an option.

If an error occurs during a restart, the screen with the Service menu is displayed immediately.

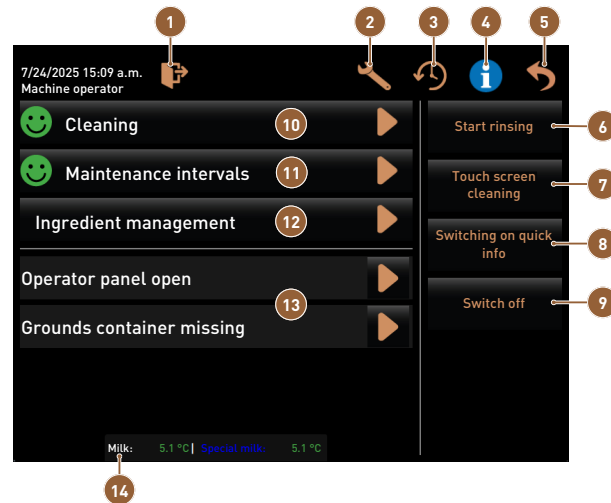



Fig. 105: Screen for functions in the Service menu

- | | |
|---|---|
| <p>1 Logs out the currently registered profile or opens the log-in dialog for logging in with different profiles.</p> <p>3 Shows the dialog with the beverage dispensing history and the list of dispensed beverages.</p> <p>5 Closes the screen with the Service menu and takes you back to the user interface.</p> <p>7 Direct selection: Locks the screen for 30 s for screen cleaning.</p> <p>9 Direct selection: Switches the machine off.</p> <p>11 Displays the maintenance status and opens the screen for carrying out maintenance.</p> <p>13 Displays pending messages and opens the dialog with the respective instruction for action and its acknowledgment.</p> | <p>2 Opens the screen with the machine settings.</p> <p>4 Shows the dialog with system information including QR code.</p> <p>6 Direct selection: Starts rinsing process.</p> <p>8 Direct selection: Displays a quick info message.</p> <p>10 Displays the cleaning status and opens the screen for performing cleaning.</p> <p>12 Opens the screen for ingredient management.</p> <p>14 Optional: Displays the milk temperature.</p> |
|---|---|

General buttons in the Service menu

- Use the **Confirm**  button to start pending actions or confirm displayed instructions for action.
- The **Next**  button takes you step to step through the display-guided action steps for cleaning, descaling or grinder service.

9.9.3 Quick info

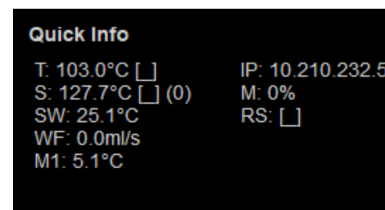

Fig. 106: Quick info

The quick info appears on the Service menu screen and provides information on the following parameter values:

- T** displays the hot water boiler temperature in °C.
- S** displays the steam boiler temperature in °C.

- **SW** displays the steam wand temperature in °C.
- **WF** displays the required water quantity in ml/s.
- **M1** displays the current milk temperature.
- **IP** displays the address of the network adapter.
- **M** displays the available storage space in %.
- **RS** informs about the density of beverage supply (Rush hour mode).
Rush hour mode is activated if more than 30 beverages are dispensed per hour. When this mode is active, rinsing of the beverage outlet is suppressed. The active mode is indicated by **RS[*]**.

9.9.4 Logging into a profile

Access rights to functions and parameters depend on the profile.

Variant: access to the Service menu without PIN entry

- ☞ Tap on the **Service menu**  button in the user interface.
- ✓ The Service menu opens with the last activated user profile or without an active profile (not logged in).

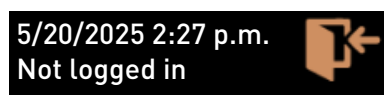



Fig. 107: Not logged in button

Variant: access to the Service menu with PIN entry

Each profile has specific authorizations. Logging in with a profile can be protected by a PIN. Service technicians can activate and deactivate profiles, define a PIN and assign it to a profile.

- ☞ Access to the Service menu is protected by a PIN.
- ☞ Tap on the **Service menu**  button in the user interface.
 - ✓ The numeric keypad for entering the PIN appears.
- ☞ Enter the configured PIN and confirm.
- ✓ The screen with the Service menu opens without an active user profile.
- ✓ All direct dial functions with the exception of **Free sales** are available for selection.
- ✓ **Info – Show versions** is available in the settings.

Access to the Profiles dialog

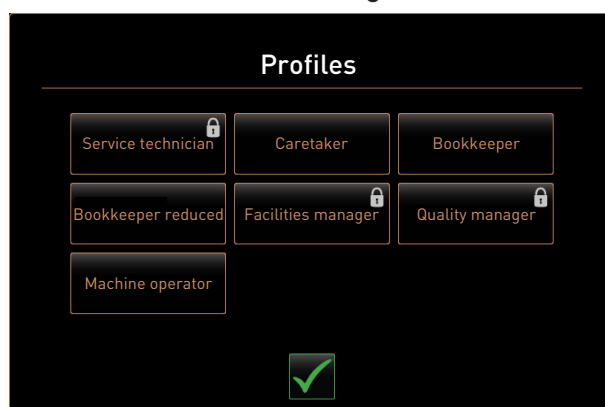



Fig. 108: Profiles dialog

- ☞ Tap on the **Log-in** button  in the Service menu.
- ✓ The **Profiles** dialog opens with the profiles configured by service technicians.

- ✓ PIN-protected profiles are marked with a lock icon.

When the Service menu is closed, the currently logged in profile remains active.

The active profile is only logged out after logging out using the button or after a restart.

The following profiles can be enabled by service technicians:

- Caretaker
- Bookkeeper
- Bookkeeper reduced
- Head of service
- Quality manager
- Machine operator

Variant for activating unprotected profile

- ☞ Select the desired unprotected profile, e.g. **Caretaker**.
- ✓ The Service menu is displayed with the active **Caretaker** profile.
- ✓ The functions available in the Service menu correspond to the selected profile.

Variant for activating protected profile

- ☞ The profile is protected by a PIN and labeled with a lock icon.
- ☞ Select the desired protected profile, e.g. **Service technician**.
 - ✓ The numeric keypad for entering the PIN opens.
- ☞ Enter the configured PIN and confirm with .
- ✓ The Service menu is displayed with the selected profile.

Profile log out

- ☞ Tap on the **Log-out**  button in the Service menu.
- ✓ The active profile is logged out.
- ✓ Any authorizations become void.
- ✓ **Not logged in** is displayed in the Service menu.

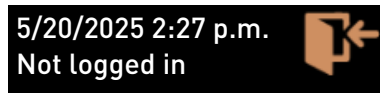

Fig. 109: Not logged in button

See also

- ☞ Advanced settings [▶ 190]
- ☞ Profiles and authorizations [▶ 192]

9.9.5 Functions in the Service menu

In general, a green smiley indicates that cleaning or maintenance is complete. A red smiley indicates that cleaning or maintenance is pending.

See also

- ☞ Advanced settings [▶ 190]
- ☞ Logging into a profile [▶ 104]
- ☞ Cleaning [▶ 116]

9.9.5.1 Starting cleaning



Fig. 110: Cleaning button

PIN-protected function (caretaker, operator, service technician)

- ☞ Tap on the **Cleaning** button.
- ✓ Display-guided cleaning starts.
- ✓ It is possible to cancel using the **X** button.
- ✓ The last cleaning performed is displayed.

9.9.5.2 Performing maintenance work



Fig. 111: Maintenance overdue

PIN-protected function (caretaker, operator, service technician)

- ☞ Execute the displayed maintenance work.
- ☞ Tap on the **Maintenance** button.
 - ✓ It is possible to cancel using the **X** button.
- ☞ Acknowledge the maintenance work.
- ✓ The acknowledged maintenance work is displayed with the date and a green smiley.

9.9.5.3 Ingredient management



Fig. 112: Ingredient management button

The **Ingredient management** button calls up the ingredient management. Available ingredients, e.g. the milk system, can be activated and deactivated here.

Activating ingredient

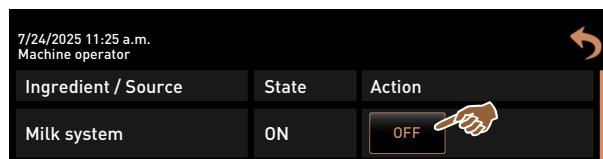

Fig. 113: Activate milk system

- ☞ Tap on the **Ingredient management** button.
 - ✓ The screen with the active ingredients opens.
- ☞ Tap on the **ON** button in the **Action** column.
 - ✓ The ingredient is activated.
- ☞ Tap on **←** to return to the Service menu.

9.9.5.4 Changing syrup bottles

- ☞ Tap on the **Ingredient management** button.
 - ✓ The screen with the active ingredients opens.

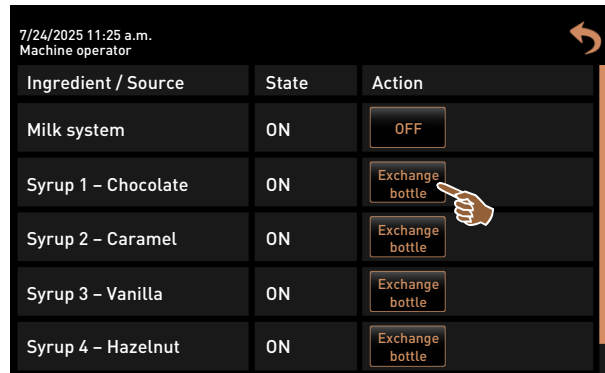

Fig. 114: Bottle change

- ☞ Tap on the **Bottle change** button for syrup types 1 to 4 in the **Action** column.
 - ✓ The **Bottle change** screen shows the display-guided steps.
 - ✓ The previously selected syrup hose is drained.
- ☞ Remove the bayonet lock from the empty bottle at the Flavour Point and thoroughly clean the hose with the bottle adapter.
- ☞ Confirm completed cleaning with
- ☞ Insert the bottle adapter with the cleaned hose into the new syrup bottle.
- ☞ Reconnect the bayonet lock back to the Flavour Point.



Fig. 115: Start pump

- ☞ Tap on the **Start pump** button and then the **Stop pump** button to refill the hose.
- ☞ Confirm hose filling with
- ✓ The **Bottle change** screen closes. The desired user interface appears.

9.9.5.5 Error messages in the Service menu

Pending machine errors are displayed in the **Error messages** area.

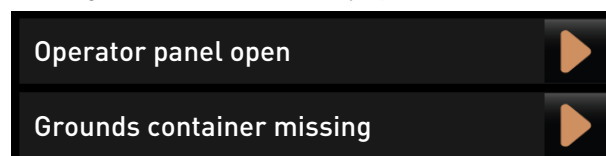



Fig. 116: Error message buttons

Remedying error

- ☞ Open the pending message with
- ✓ The pending message appears in a separate window.

- ☞ Correct the pending error or carry out the required action.
- ✓ The error message or the action request is automatically deleted from the list.
- ✓ Service technicians can see an overview of events in the **Info > Error statistics** main menu.

9.9.5.6 Back to user interface

The  button takes you back to the user interface.

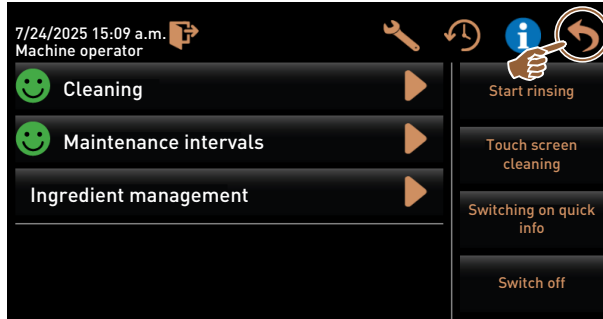



Fig. 117: Back to user interface

- ☞ Tap on .
- ✓ The desired user interface appears.
- ✓ The logged-in profile is logged out.

9.9.5.7 Displaying system information



Fig. 118: Calling up system information

- ☞ Tap on .
- ✓ The system information is displayed in a separate window.
- ✓ A QR code with system information also appears.

9.9.5.8 Displaying beverage dispensing history

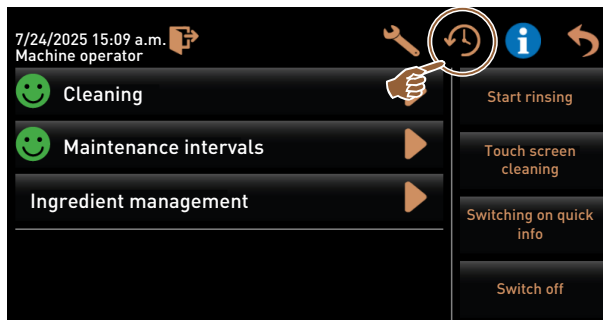



Fig. 119: Calling up beverage dispensing history

- ☞ Tap on .

- ✓ The **Beverage dispensing history** dialogue opens and all beverages already dispensed are shown in a list.
- ✓ The corresponding beverage dispensing duration is also displayed for each dispensed beverage.
- ✓ The pure beverage dispensing time (coffee) is shown on the right side of the list.



Beverage dispensing history			
07/28/2025 7:50 a.m.	M ristretto	30.5s	1.9s
07/28/2025 7:43 a.m.	M hot milk	28.4s	-
07/28/2025 7:42 a.m.	M espresso	26.9s	2.0s
07/28/2025 7:38 a.m.	M espresso	27.2s	1.9s
07/28/2025 7:35 a.m.	M cappuccino	36.6s	1.9s

Fig. 120: Beverage dispensing history dialog

The pure dispensing time for single coffee beverages should be between 10 and 15 s and 20 to 25 s for double beverages. However, this is only a reference value and can vary due to the grind quantity, grinding level, water quantity, water temperature and coffee type.

9.9.5.9 Opening settings

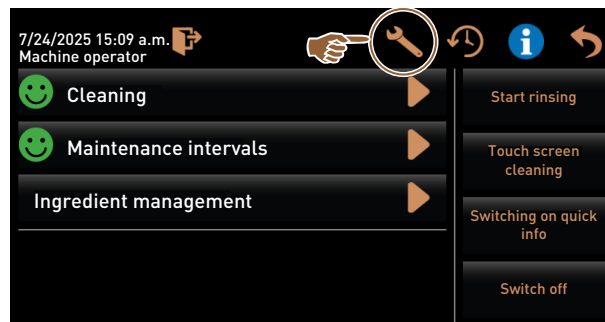



Fig. 121: Calling up settings

- ☞ Tap on .
- ✓ The settings appear.
- ✓ Parameter settings are available.

The access authorization for parameter settings depends on which profile is logged in.

9.9.5.10 Direct selection

The following actions are triggered with the direct selection buttons.

“Start rinsing” direct selection



Fig. 122: Start rinsing button

- ☞ Tap on the **Start rinsing** button.
- ✓ A hot rinse is carried out for all existing systems.

- ✓ The rinsing process cannot be cancelled.

Touch screen cleaning direct selection

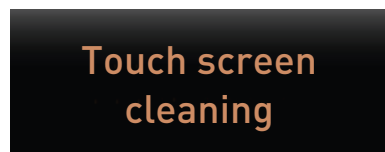

Fig. 123: Touch screen cleaning button

- ☞ Tap on the **Touch screen cleaning** button.
- ✓ The display remains insensitive for a period of 30 s and can be cleaned.

“Switch on quick info” direct selection

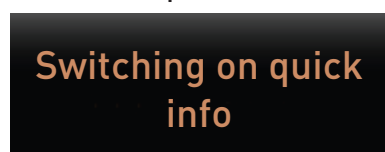

Fig. 124: Switch on quick info button

- ☞ Tap on the **Switch on quick info** button.
- ✓ The Quick info window with the operating statuses appears floating in the foreground.

Switch off Quick Info

- ☞ Tap on the **Switch off quick info** button.
- ✓ The Quick info window closes.

“Activate free vending” direct selection (with payment system)



Fig. 125: Activate Free vending mode button

- ☞ Tap on the **Activate free vending** button.
- ✓ Beverages usually available for a change are available for free vending.
- ✓ The **Activate free vending** button is accessible to service technicians, bookkeepers and caretakers.

“Switch-off” direct selection



Fig. 126: Switch-off button

- ☞ Tap on the **Switch-off** button.
- ✓ The machine is powered down.
- ✓ The machine is powered down, but not de-energized.
- ✓ The display is blank and inactive.

See also

📄 Cleaning [▶ 116]

9.10 Emptying

Containers with used residues must be emptied periodically.

9.10.1 Emptying grounds container

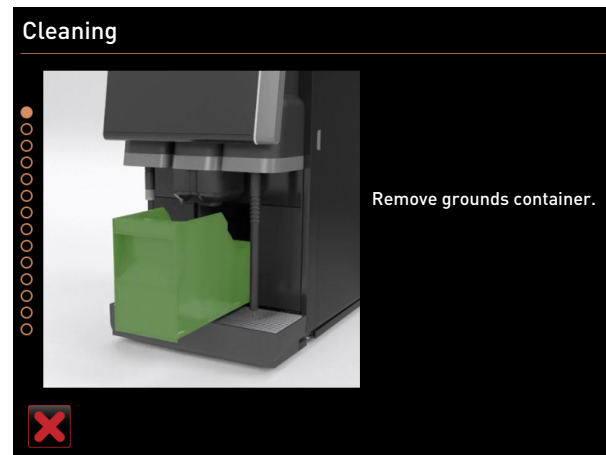

Fig. 127: Emptying grounds container

Emptying standard grounds container

The standard grounds container holds approx. 60 – 70 coffee cakes. After this number has been reached, the instruction for emptying the grounds container appears in the user interface.

- ☞ For machines with manual beverage outlet: Slide the beverage outlet upwards as far as it will go.
- ☞ Pull the grounds container out of the machine to the front.
 - ✓ The Grounds container removed message appears on the display.
- ☞ Empty and clean the grounds container.
- ☞ Dry the grounds container and push it back into the machine as far as it will go.
 - ✓ The machine is ready for use.

Emptying under-counter grounds container

- ☞ For machines with manual beverage outlet: Slide the beverage outlet upwards as far as it will go.
- ☞ Pull the integrated grounds container out halfway.
 - ✓ Accidental beverage dispensing is prevented.
- ☞ Empty and clean the under-counter grounds container.
- ☞ Place the under-counter grounds container back under the grounds chute of the machine.
- ☞ Push the integrated grounds container back in as far as it will go.
 - ✓ The machine is ready for use.



NOTE

Property damage due to possible overfilling of the under-counter grounds container!

The under-counter grounds container is not monitored. There is a risk of overfilling. During emptying, it is possible to select a beverage without the under-counter grounds container.

- ☞ Check the under-counter grounds container according to machine usage.
- ☞ Make sure that no beverages can be dispensed while the under-counter grounds container is being emptied.

9.10.2 Emptying external waste water tank

The machine has a waste water outlet. The drip tray is fixed and cannot be removed.



Fig. 128: External waste water tank

- ☰ Ensure that no beverages can be dispensed before the waste water tank is removed.
- ☞ Slide the manual beverage outlet upwards as far as it will go.
- ☞ Pull the grounds container out of the machine to the front.
 - ✓ The **Grounds container removed** message appears on the display.
- ☞ Remove the cover with the waste water hose from the external waste water tank.
- ☞ Empty the waste water tank.
- ☞ Clean the waste water tank thoroughly with household cleaner and rinse it out with fresh water.
- ☞ Check that the level monitoring floater is working.
- ☞ Insert the cover with the waste water hose back into the tank.
- ☞ Reinsert the grounds container into the machine.
- ✓ The machine is ready for beverage dispensing.

See also

- ☰ Connecting water [▶ 56]

9.11 Switching off

The machine and its optional accessories can be switched off in various ways, as described below.

9.11.1 Switching machine to standby



DANGER

Danger to life from electrocution!



The machine is still powered in Standby mode.

- ☞ Remove the machine casings.
- ☞ Always disconnect the machine from the power supply before repair work.



CAUTION

Risk of scalding from machine rinsing!

Before switching off, the machine may perform an automatic machine rinsing process. During machine rinsing, hot water runs out of the beverage outlet. An automatic machine rinse is indicated by a message on the display. The functional light turns red.

- ☞ Do not reach under the beverage outlet during a machine rinse.



NOTE

No warranty in the event of non-compliance with instructions!

In the event of non-compliance with the safety notes and handling information, no warranty will be accepted in the event of property damage.

- ☞ To avoid damage to the machine, follow the safety notes and handling information in the operating instructions.



NOTE

Save energy!

If the machine is not going to be used for several hours, it should be switched off to save energy.

Rinsing before switching off



Fig. 129: Start rinsing button

- ☞ In the Service menu, tap on the **Start rinsing** button if it has not already been performed.
 - ✓ Rinsing is performed.
- ☞ Carry out daily and weekly cleaning as required.
- ☞ If present, empty and clean the external drinking water tank.

After automatic cleaning, the machine can be switched off directly from the cleaning program.

Switching off using the touch screen



Fig. 130: Switch-off button

- ☞ Tap on the **Switch-off** button in the Service menu.
 - ✓ The machine is switched off.
 - ✓ The display is not displaying.
 - ✓ The machine is in Standby mode.

Switching off using machine On/Off button

The machine can also be switched off using the On/Off button behind the user panel.

See also

- 📖 Switching on machine [▶ 76]

9.11.2 Longer downtimes (from 1 week)



NOTE

Property damage due to frozen water!

The boilers can be damaged by freezing water as it expands.

- ☞ If the machine may be exposed to below-freezing temperatures, drain the entire water system as far as possible beforehand.
- ☞ Contact your service partner.

During longer downtimes, for instance company vacations, take the machine and other associated devices out of operation.

When restarting the machine, first perform a daily cleaning.

Taking machine out of operation

- ☞ Switch the machine to Standby mode.
- ☞ Disconnect the power connection by pulling out the power plug or switching off a main switch installed on site.
- ✓ The machine is de-energized.

9.11.3 Switching off optional accessories



CAUTION

Damage to property and health problems due to pollution!

Switched off optional accessories that have not been cleaned can cause health problems and technical faults due to contamination and moisture in the interior when they are switched back on.

- ☞ Carry out daily machine cleaning before switching off the milk-carrying accessories.
- ☞ Accessory parts such as milk container, cover and adapter must be stored in a clean and dry place.
- ☞ Disconnect the machine from the power supply if the optional accessories are to remain switched off for a long period of time.
- ☞ **Before long breaks in operation:**
 Disconnect the devices from the power supply.
 Clean the interior of the cooling unit.
 Lean the door of the cooling unit against the wall and do not close it completely.

Switching off optional accessories

- ☞ Drain the milk container in optional accessories that come into contact with milk.
- ☞ Clean the machine daily.

- ☞ Clean accessories such as the milk container, cover and adapter in a dishwasher or rinse them thoroughly by hand in clean water.
- ☞ Switch off the optional accessory using the main device switch.
- ☞ Keep accessories clean and dry.
- ☞ Disconnect the power connection by pulling out the power plug.
- ✓ The optional accessory is de-energized.
- ✓ The optional accessory can be stored for a long period of time.

Deactivating cup warmer lighting

- ☒ The lighting is activated and a selected color lights up permanently.
- ☞ Use a pin with a diameter of approx. 2-3 mm to press the button for the top lighting on the rear casing for approx. 2 s.
- ✓ The lighting is disabled.

Switching off cup warmer

The instructions also apply to the cup warmer unit in the Cup & Cool device.

- ☞ Press the On/Off button in the top left on the rear casing.
- ☞ For long breaks in operation: Pull out the power plug.
- ✓ The On/Off button no longer lights up.
- ✓ The cup warmer is switched off.

10 Cleaning

Cleaning is a prerequisite for safe and trouble-free operation. That means it is of the utmost importance and must be carried out in accordance with the described regulations.

Canceled cleaning

The machine can only be ready for use again if the cleaning process has been correctly completed. A cleaning process that has not been fully and correctly completed (e.g. due to a power supply failure) must be repeated.



WARNING

Risk of injury due to insufficient qualification!

Improper handling can lead to considerable personal injury and property damage.



The following activities may only be carried out by persons who have been instructed by the operator.



CAUTION

Risk of injury due to slipping!

Leaking liquid can lead to a wet floor around the machine. This can lead to injuries from slipping and falling.



-  Dry any spilled liquids on the floor immediately after spills occur.
-  Indicate large quantities of leaked liquid on the floor with a mobile warning sign.



CAUTION

Risk of scalding due to hot fluid!

There is a risk of scalding in the dispensing area for beverages, hot water and steam.





-  Never reach under the dispensing points during dispensing or cleaning.
-  Always lock the control unit before cleaning to prevent accidental input.



CAUTION

Risk of infection from contamination!

Contamination can lead to infections. Infection can lead to health problems.

-  Always carry out cleaning after installation, commissioning or after recommissioning.
-  Carry out all cleaning processes before and after breaks in operation of several days.
-  Run the display-guided cleaning program before the first beverage dispensing process.
-  Rinse the machine before switching it off.

10.1 Cleaning regulations and conditions

HACCP cleaning concept: **HACCP** stands for **Hazard Analysis Critical Control Point**.

The HACCP cleaning concept is intended to ensure that food is safe. Hazards associated with the processing of food or those emanating from finished products are considered and the risks assessed. The risks are mitigated by taking appropriate measures.

With proper installation, maintenance, care and cleaning, our machines and devices fulfill the HACCP requirements.

All recommended cleaning products are perfectly coordinated with the cleaning programs.



WARNING

Risk of infection due to bacteria!



Improper care and cleaning can make the dispensing of beverages hazardous in terms of food hygiene.

- Wear protective gloves while cleaning.
- Wash your hand thoroughly before and after cleaning.
- Clean the machine daily.
- For machines with milk system: Clean the milk container before each refill and after the end of dispensing.
- When cleaning the milk system with cleaning powder: Never add cleaning products to the milk container; always use the blue cleaning container.
- Never add cleaning products to the drinking water tank (internal/external).
- Never mix cleaning products.
- Store cleaning products separately from coffee, milk and automatic coffee machine powder (if available).
- Do not use abrasive cleaners, brushes or metal cleaning instruments.
- Do not touch any parts that come into contact with beverages after cleaning.
- Observe the dosing and safety notes on the cleaning product and follow them.

10.2 Cleaning products



WARNING

Risk of poisoning from cleaning products!



There is a risk of poisoning if cleaning products are ingested.



- Only use cleaning products recommended by the manufacturer.
- Read the information on the packaging and the safety data sheet carefully before using the cleaning product. If no safety data sheet is available, request one from the sales partner.



- Keep cleaning products away from children and unauthorized persons.
- Do not touch the cleaning products with your bare hands and do not ingest them.



- Never mix cleaning products with other chemicals.
- Only use cleaning and descaling products for their intended purpose (see label).
- Do not eat or drink while using cleaning products.
- Ensure good ventilation when using cleaning products.
- Wear protective gloves and protective goggles when using cleaning products.
- Wash your hands thoroughly immediately after using cleaning products.



NOTE

Property damage due to incorrect cleaning products!

The machine can be damaged if the wrong cleaning products are used.

- Only use cleaning products recommended by the machine manufacturer for daily and weekly cleaning.

Cleaning tablets for the coffee system



Name	Coffeepure tabs
Intended use	Cleaning the coffee system
Cleaning purpose	Removing grease residues in the coffee system
Application interval	Once a day
Application	Instruction to insert a tablet during display-guided cleaning

Cleaning powder for the milk system



Name	Milkpure powder
Intended use	Milk system cleaning
Cleaning purpose	Removal of milk fat and bacteria in milk system
Application interval	Once a day
Application	<p>Division of cleaning bags:</p> <ul style="list-style-type: none"> ▪ 4x alkaline = green = Cleaner 1 ▪ 1x acid = red = Cleaner 2 <p>For daily cleaning, perform four intervals with Cleaner 1 and the fifth interval with Cleaner 2.</p> <p>Instruction to add cleaning powder during display-guided cleaning</p>

Reordering cleaning product



Name	Reordering set
Intended use	Coffee and milk system cleaning
Contents	<ul style="list-style-type: none"> ▪ A package of cleaning tablets for the coffee system: Coffeepure tabs ▪ Two packages of cleaning powder for the milk system: Milkpure powder
Quantity	<p>Cleaning products for 100 daily cleanings:</p> <ul style="list-style-type: none"> ▪ 100x cleaning tablets ▪ 80x Cleaner 1 cleaning powder (green) ▪ 20x Cleaner 2 cleaning powder (red)

10.3 Cleaning stages

The following cleaning stages are possible:

- **Request** = The coffee machine is still ready for use.
- **Forced** = The coffee machine is locked.

The cleaning level of a cleaning operation can only be adjusted by service technicians.

Variant: request



- Information is provided about pending cleanings.
- An orange colored marking is displayed on the Service menu button when cleaning is pending.
- The time until the next cleaning is due is displayed in hours in the Service menu.
- The Cleaning button in the Service menu uses a red smiley 😞 to show when cleaning is needed.

Variant: forced



A pending cleaning with an active mandatory cleaning status cannot be postponed. The pending cleaning program does not allow for any more beverage dispensing.

Not until the cleaning programme is run is the machine ready for use again.

Mandatory cleaning and the period that elapses before it is enforced can be defined in the cleaning schedule by a service technician.

- Information is provided about pending cleanings.
- An red colored marking is displayed on the Service menu button when cleaning is pending.
- The time until the next cleaning is due is displayed in hours in the Service menu.
- The Cleaning button in the Service menu uses a red smiley 😞 to show when cleaning is needed.

When cleaning with Procure, it is also possible to start cleaning in the following ways:

- **Automatic** = Cleaning starts automatically without operator intervention.
- **Manual** = Cleaning only starts with operator intervention.

Cleaning time window

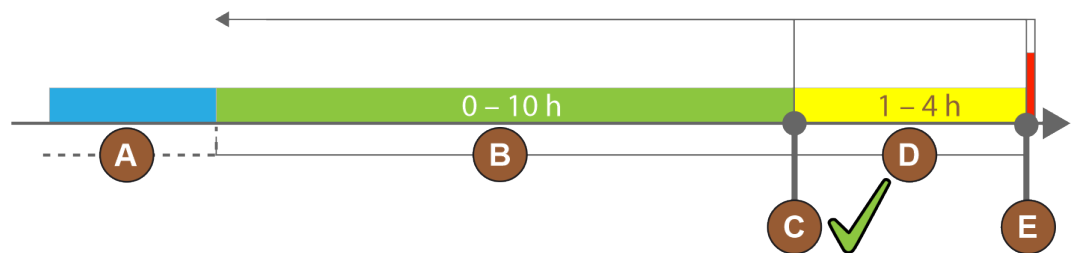

Fig. 131: Time window for cleaning

Pos.	Time window	Explanation
A	Cleanings performed in this time window are ignored.	The cleaning instruction remains unchanged after a cleaning.
B	Cleanings performed in this time window are too early. These cleanings are still recognized as completed.	The cleaning instruction is reset after a cleaning. The next cleaning due in the cleaning schedule is displayed in h in the Service menu.
C	Displays the time for the optimum start of cleaning (according to the schedule).	The time remaining until the optimum start time is displayed in the Service menu.

Pos.	Time window	Explanation
D	Displays the time window for optimum cleaning in the schedule.	The cleaning instruction is reset after a cleaning.
E	Displays the time for mandatory cleaning. Cleaning that has not been performed can no longer be delayed from this point onwards.	The display shows that further dispensing is no longer possible. The machine is no longer ready for use. Cleaning is absolutely essential.

10.4 Cleaning intervals

The following sections describe the cleaning intervals required for optimum and trouble-free operation. If regular checks show increased contamination, shortening the required cleaning intervals in accordance with the actual signs of contamination is essential.

Cleaning with high beverage volume

If the daily volume of beverages exceeds the reference value of 200-250 beverages, two daily cleanings are recommended.

D	W	N	R	O	Automatic rinsing*
x					Automatic hot rinsing during startup and shutdown: internal milk system and beverage outlet rinsing
x		x			Programmed hot rinsing of coffee system and milk system every 1 – 180 min, depending on configuration
x		x		x	Programmed rinsing of the external milk hose

* Rinsing can be run manually at any time using the **Start rinsing** function.

D	W	N	R	O	Screen-guided cleaning program**
x		x	x		Coffee system cleaning, according to configured cleaning schedule
x		x	x	x	Milk system cleaning, according to configured cleaning schedule
		x		x	Rinse mixing cup with request for manual step, according to configured cleaning schedule
	x			x	Steam boiler rinsing, according to configured cleaning schedule
x			x	x	External milk hose cleaning with ProCare Plug & Clean, according to configured cleaning schedule
		x		x	Flavour Point

** Screen-guided cleaning programs are run according to the set cleaning schedule. They can also be run manually at any time using the **Additional cleaning** function.

D	W	N	R	O	Manual cleaning
x					Grounds container
x					Brewing chamber
x					Drip tray and drip grid
	x	x			Bean hoppers
x					Touch screen
		x			Lower beverage outlet part
		x			Outer machine surfaces
x				x	Rinse milk container
	x	x		x	Steam wand

D	W	N	R	O	Manual cleaning
x				x	Clean cooling unit interior
		x		x	Defrost cooling unit
x				x	Optional accessories
x				x	Rinse internal drinking water tank
x				x	Rinse external drinking water tank
x				x	External drinking water tank
		x		x	Rinse powder container
		x		x	Cooling unit outer surfaces

Legend for cleaning intervals	
D	At least once a day, more if necessary
W	At least once a week, more if necessary
N	As needed, when the machine is dirty
O	Optional equipment or feature

10.5 Machine rinsing



CAUTION

Risk of scalding due to hot water!

During machine rinsing, hot water runs out of the beverage outlet. An automatic machine rinse is indicated by a message on the display. The functional light turns red.

- ☞ Do not reach under the beverage outlet during a machine rinse.
- ☞ Point the optional steam wand into the drip tray.
- ☞ Configured rinses are started automatically. That is why you have to make sure that the beverage outlet is always free.

10.5.1 Automatic switch-on/switch-off rinsing

Automatic switch-on or switch-off rinsing is standard and cannot be deactivated.

The following systems are flushed automatically after switching on and before switching off (if available):

- Coffee system
- Milk system
- Powder system
- Hot & Cold system

10.5.2 Configured rinsings

In addition to the switch-on/switch-off flushing function, service technicians can set flushing processes for the following systems in the Service menu:

- Rinsing > beverage outlet (outlet rinsing interval) (1 – 180 min)
- Rinsing > milk system (external milk hose rinsing interval) (1 – 180 min)
- Rinsing > milk system (internal milk system rinsing interval) (1 – 180 min)
- Rinsing > reverse flow cooler (recuperator rinsing interval) (1 – 180 min)

In the default setting, configured rinsing processes are triggered every hour.

10.5.3 Manual rinsing (Service menu)

Additional rinsing processes can be triggered manually at any time in the Service menu.

- ☞ Tap on the **Service menu**  button.
- ✓ The Service menu opens.



Fig. 132: Start rinsing button

- ☞ Tap on the Start rinsing button.
- ✓ System rinsing is carried out in the same sequence as the automatic switch-on/switch-off rinsing.

10.6 Display-guided cleaning

With display-guided cleaning, all pending activities are shown on the screen using animations and instructions are displayed in text form.

The completed action steps must be confirmed on the screen in order to proceed to the next step.

10.6.1 Display-guided cleaning types



WARNING

Risk of poisoning from cleaning product residues!

Cleaning product residues on cleaned machine components can cause health problems.

- ☞ Rinse the cleaned machine components with fresh water.



CAUTION

Risk of scalding and health problems from hot fluid!

Hot cleaning fluid and hot water are dispensed during the cleaning program. Cleaning fluids can cause health problems. Hot fluids can cause scalding.

- ☞ Remove the drip grid before starting cleaning.
- ☞ Do not reach under the beverage outlet, the steam outlet or the hot water dispensing point during cleaning.
- ☞ Do not place any beverage containers (cups/mugs) under the beverage outlet, hot water dispensing point or steam wand during cleaning.



NOTE

Property damage due to flooding risk!

A plugged waste water outlet in the drip tray causes overflowing of the drip tray.

Before cleaning and descaling:

- ☞ Check that the waste water outlet is flowing freely.
- ☞ Check the drainage speed of the waste water outlet.

The display-guided cleaning programs can be divided into **scheduled cleaning** and **additional cleaning**.

Scheduled cleaning	Additional cleaning
<ul style="list-style-type: none"> ▪ The programmes are stored in the PC board of the coffee machine. ▪ The type and frequency of the cleaning programmes to be carried out is set in the Service menu via a cleaning schedule. ▪ Service technicians can configure the cleaning schedule (e.g. change the cleaning stage). 	<ul style="list-style-type: none"> ▪ Additional display-guided cleaning processes can be started manually at any time in the Service menu. ▪ The type and scope of cleaning can be activated or deactivated individually. ▪ The processes for the activated cleaning type are carried out in the same way as for scheduled cleaning.

If no **ProCare** unit is installed, both scheduled cleaning and additional cleaning are carried out with the **Coffeepure tabs** cleaning tablets and the **Milkpure powder** cleaning powder.

If a **ProCare** unit is installed, both scheduled cleanings and additional cleanings are always carried out with **ProCare**.

If a **Flavour Point** module is installed, a separate cleaning program is offered in the **Cleaning** screen.

10.6.2 Required utensils

The following utensils are required during the display-guided cleaning program without ProCare:

- A **Coffeepure tab** cleaning tablet for the coffee system
- A **Milkpure powder** cleaning powder bag for the milk system*
- A blue cleaning container for the milk system
- Commercial dishwashing detergent
- Clean commercial cleaning rags
- Collecting container for remaining milk (if needed)
- Collecting container for remaining choco powder or topping (if needed)
- The powder system equipment requires access behind the operating unit. Have the key for the optional lockable operating unit ready or open the lock beforehand.

* Perform four intervals with Cleaner 1 and the fifth interval with Cleaner 2.

10.6.3 Calling up cleaning variants

☞ Tap on the **Service menu**  button.

✓ The Service menu opens.



Fig. 133: Cleaning button

☞ Tap on the Cleaning button.

✓ The Cleaning screen opens.

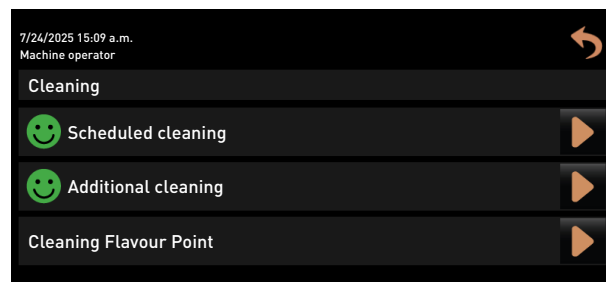

Fig. 134: Screen with selection of cleaning types

The following cleaning types are possible:

- Scheduled cleaning

- Additional cleaning
- Flavour Point cleaning (optional)

10.6.4 Starting scheduled cleaning (without ProCare)

The cleaning program is started in the Service menu. All actions required by the user are shown on the touch screen.

- A pending cleaning is displayed on the **Service menu** button.



Fig. 135: The **Service menu** button with pending cleaning

- ☞ Remove the drip grid for separate cleaning.
- ☞ Tap on the **Service menu**  button.
 - ✓ The Service menu opens.
- ☞ If the cleaning program is PIN-protected, enter the PIN configured for this purpose.
 - ✓ Authorization is granted.
 - ✓ The **Cleaning** button is now active.



- ☞ Tap on the **Cleaning** button.
 - ✓ The **Cleaning** screen opens with the menu items for the various cleaning types.
- ☞ Tap on the **Scheduled cleaning**  button.

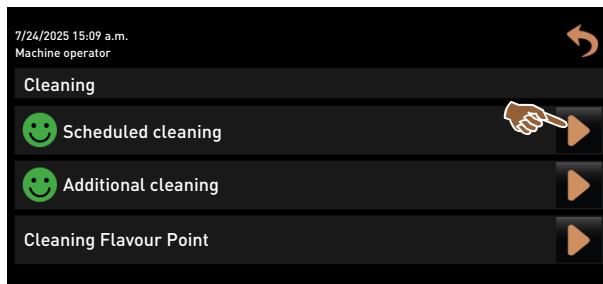

Fig. 136: Opening scheduled cleaning

- ✓ The **Cleaning according to schedule** dialogue opens.

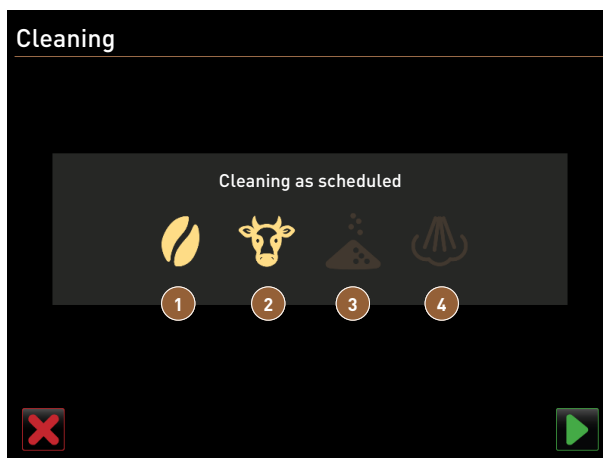



Fig. 137: Dialog for cleaning according to cleaning schedule

1 Cleaning of coffee system

2 Cleaning of milk system

3 Cleaning of powder system

4 Cleaning of boiler system

- ☞ Start the scheduled cleaning with .
- ✓ Cleaning is started according to the set cleaning schedule.
- ✓ The systems to be cleaned are highlighted in the dialog with their icon.

Screen-guided manual cleaning steps

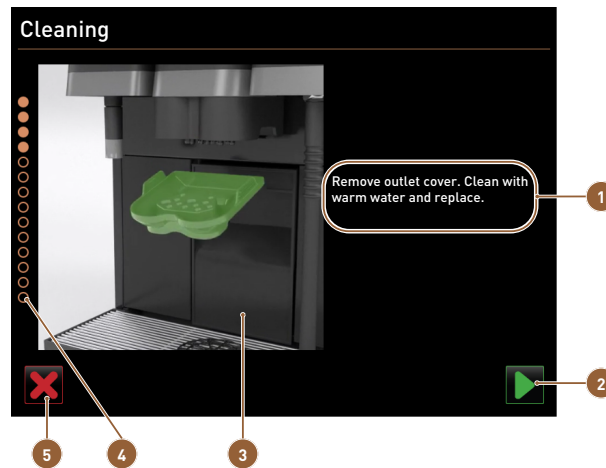



Fig. 138: Start dialogue for cleaning programme

1 Action request or information text	2 Next button to the next step
3 Image or animation of the current action	4 Progress screen
5 Button for cancelling cleaning	

- ☞ Follow the instructions on the screen.
- ☞ After completing the activities shown on the screen, tap on  to go to the next cleaning step.

Manual cleaning: grounds container

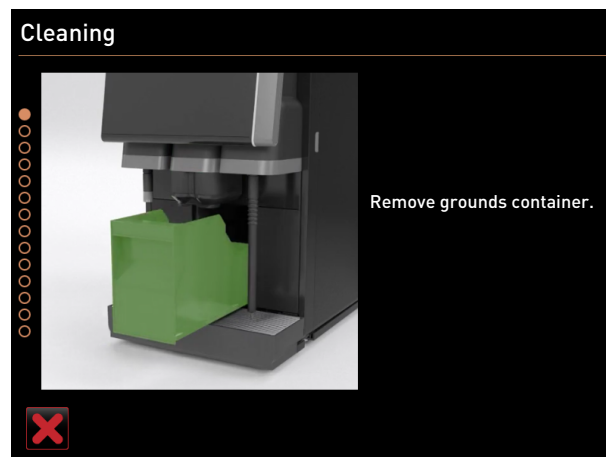

Fig. 139: Removing grounds container

- ☞ Push the beverage outlet upwards.
- ☞ Pull the grounds container out of the machine.

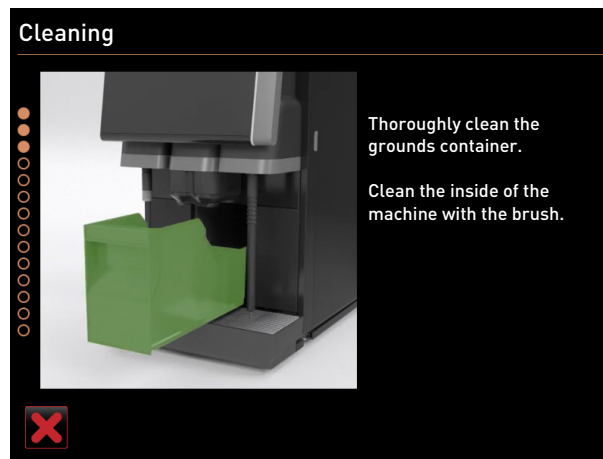

Fig. 140: Reinserting grounds container

- ✓ The instruction to thoroughly clean the grounds container, clean the machine interior with a brush and reinsert the grounds container appears.
- ☞ Wipe any remaining ground coffee out of the brewing chamber with the brush.
- ☞ Empty the grounds container, rinse it with fresh water and detergent, then dry.
- ☞ Reinsert the grounds container into the cooling unit up to the stop.
- ✓ The **Remove beverage outlet cover** instruction appears.

Manual cleaning: beverage outlet cover

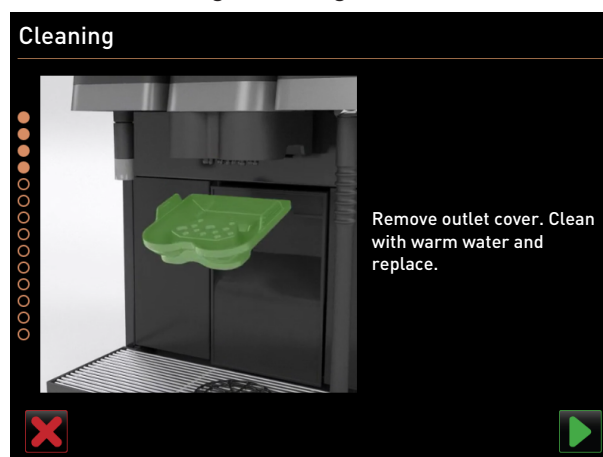



Fig. 141: Removing beverage outlet cover

- ☞ Release the beverage outlet cover by pressing it in the centre and pulling it down at the same time.
- ☞ Clean the beverage outlet cover under warm running water using a brush.
- ☞ **CAUTION! Risk of scalding from hot splashes during beverage dispensing!** An incorrectly inserted cover can result in splashing during beverage dispensing. Reinsert the cleaned cover by latching the cover in at the back and snapping it into place at the front.
- ☞ Check that the beverage outlet cover is correctly positioned.
- ☞ Use the  button to proceed to the next step.
- ✓ The instruction for inserting the **Coffeepure tab** cleaning tablet appears.

Inserting Coffeepure tab cleaning tablet

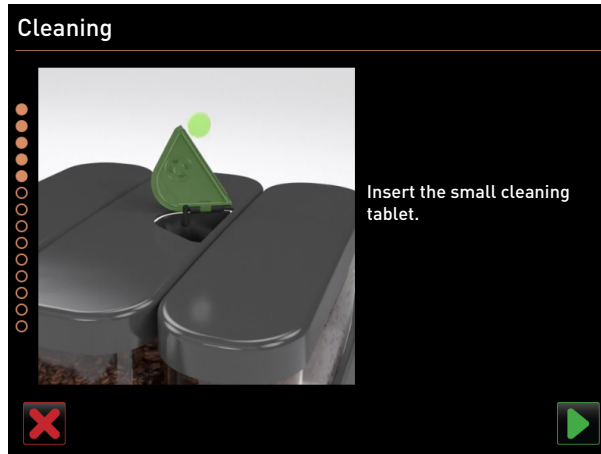



Fig. 142: Inserting cleaning tablet

- ☞ Insert the **Coffeepure tab** cleaning tab into the slot of the manual inlet of the centre bean hopper.
- ☞ Confirm insertion with .
- ✓ The **Remove milk container** instruction appears.

Cleaning milk container (optional)

Required cleaning product: **Milkpure powder**



Fig. 143: Milkpure powder cleaning powder in sachet

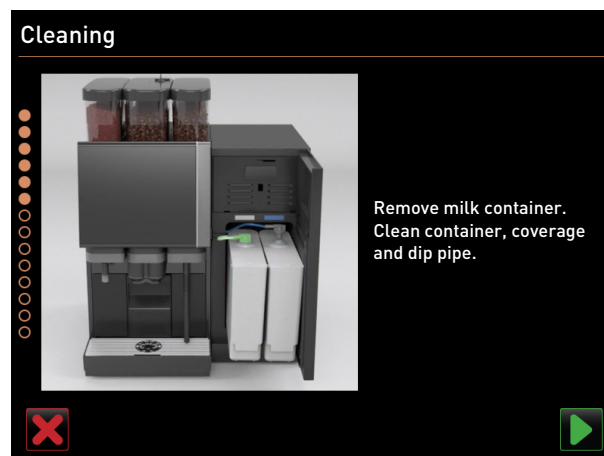



Fig. 144: Cleaning milk container (optional)

- ☞ Open the door of the cooling unit.
- ☞ Remove the milk container(s) from the cooling unit.

- ☞ Pour any remaining milk into other containers if necessary.
- ☞ Clean the milk container, cover and riser pipe with fresh water and detergent and rinse them thoroughly.
- ☞ Use the  button to proceed to the next step.
 - ✓ The instruction to add cleaning powder to the blue cleaning container appears.

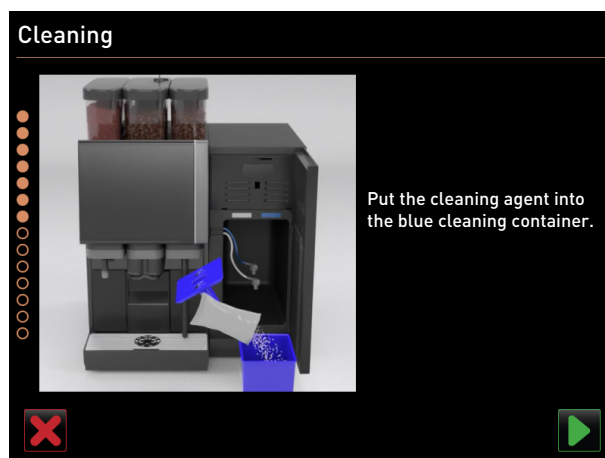



Fig. 145: Pouring cleaning product into cleaning container

- ☞ Pour the contents of one sachet of **Milkpure powder** (blue or red according to the order on the packaging) into the cleaning container.
- ☞ Insert the blue cleaning container into the cooling unit.
- ☞ Insert the adapter of the milk hose (or milk hoses for **Twin Milk**) into the cover of the cleaning container.
- ☞ Confirm the inserted cleaning container and added Milkpure powder cleaning with .
- ✓ The request to remove the mixing cup (optional) appears.

Manual cleaning: mixing cup (option)



Fig. 146: Lifting operating panel

- ☞ Unlock the operating panel at the top by pulling it firmly towards yourself.
 - ✓ The operating panel is unlocked.
- ☞ Push the operating panel upwards from below with both hands as far as it will go.
 - ✓ The operating panel is automatically held in the upper position.
 - ✓ The mixing cup is accessible.



Fig. 147: Pulling out mixing cup

- ☞ Pull the mixing cup out of the machine by the recessed grip.
- ☞ Confirm that the mixing cup has been removed with .

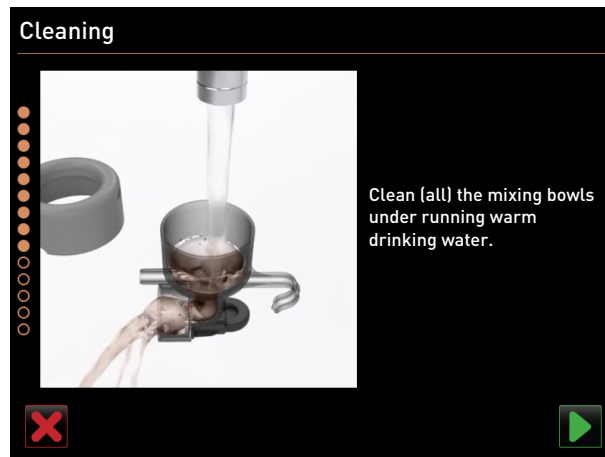



Fig. 148: Cleaning mixing cup

- ☞ Clean and rinse the individual parts of the mixing cup under clean, warm water.
- ☞ Wipe the mixing cup dry with a clean cloth.
- ☞ Confirm that the mixing cup has been cleaned with .

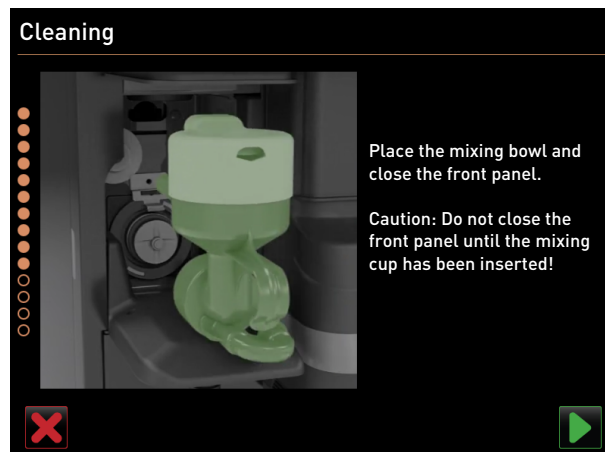



Fig. 149: Inserting mixing cup

- ☞ Reinsert the mixing cup.

- ☞ **NOTICE! Damage to the machine due to flooding!** An incorrectly inserted mixing cup can cause flooding.
Make sure the mixing cup is seated correctly.
- ☞ Close the operating panel again.
- ☞ Confirm that the mixing cup has been cleaned and inserted with .
- ✓ The cleaning process starts.

Progress display for automatic cleaning

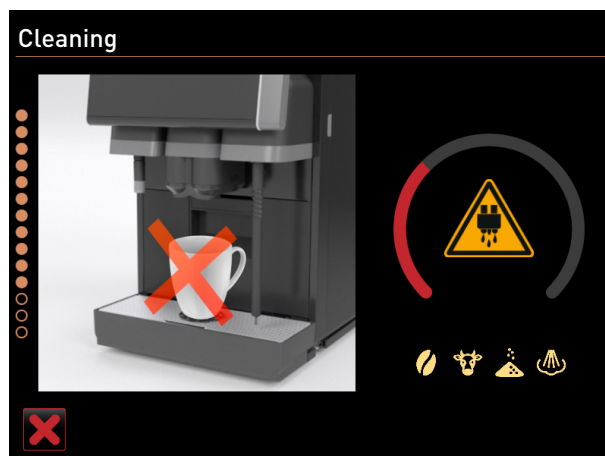

Fig. 150: Progress screen for cleaning

During cleaning, the screen shows the following:

- The crossed-out cup indicates that no beverages are available at this time.
- The progress circle indicates the completed and remaining cleaning process.
- A warning of hot escaping liquids is indicated by a warning symbol.
- The systems to be cleaned are highlighted with their icon.

Removing cleaning container

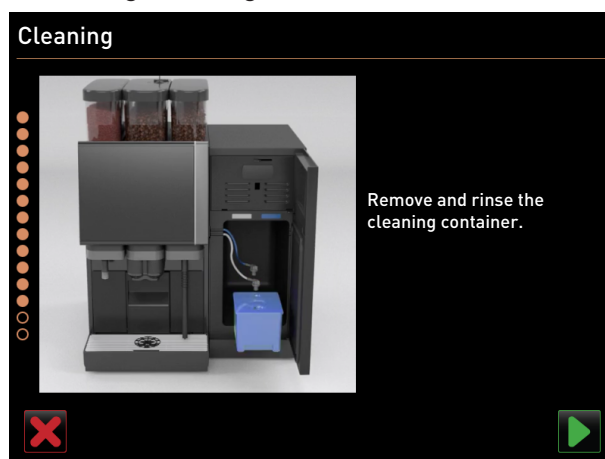



Fig. 151: Removing cleaning container

- ☞ Pull the adapter(s) of the milk hose out of the cover of the cleaning container and wipe the adapter(s) with a damp cloth.
- ☞ Remove the cleaning container from the cooling unit.
- ☞ Clean and rinse the cleaning container under clean, warm water.
- ☞ Confirm removal of the cleaning container with .

Activate milk system

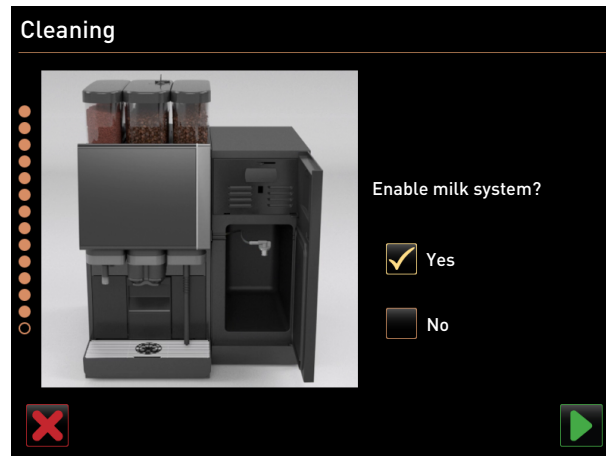



Fig. 152: Activate milk system

- ☞ Activate the milk system and confirm with .
- ✓ The dialogue with the instruction to insert the milk container(s) appears.

Reinserting milk container



WARNING

Risk of poisoning from cleaning products!



Residues of cleaning products are hazardous to health.

- ☞ After cleaning is complete, wash your hands thoroughly with commercially available soap.

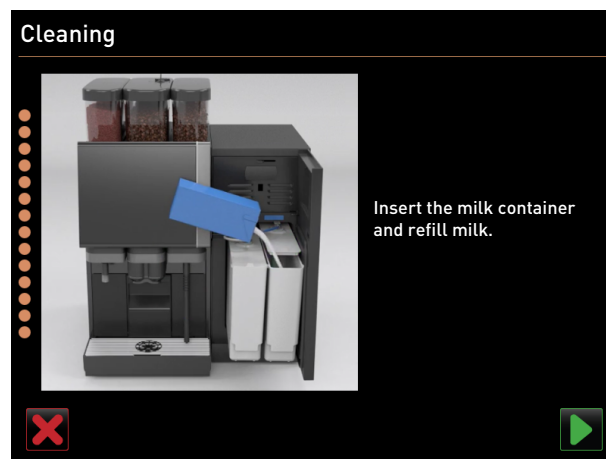



Fig. 153: Inserting milk container

- ☞ Reinsert the cleaned milk container(s) into the cooling unit.
- ☞ Insert the milk tube adapter back into the cover of the respective milk container.
- ☞ If needed, fill with fresh and pre-cooled milk (3 °C – 5 °C or 37.4 °F – 41 °F).
- ☞ For machine equipment with **Twin Milk**: Refill both milk containers.
- ☞ Confirm connection of the milk container(s) with .
- ✓ The **Switch on milk system** status screen appears.
- ✓ The systems are rinsed.
- ✓ The system is reset.
- ✓ The next scheduled cleaning in hours [h] is displayed in the Service menu.

Completion of planned cleaning

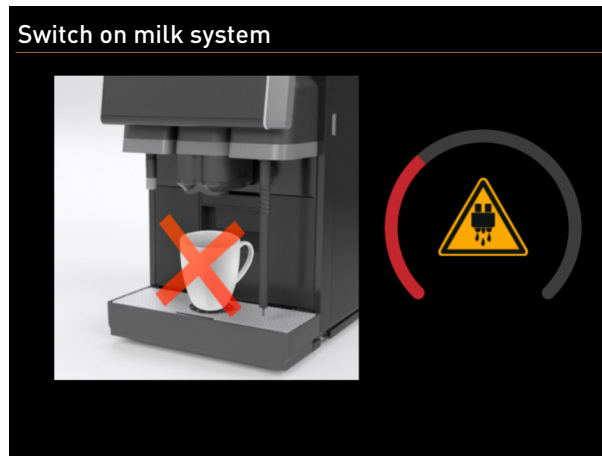

Fig. 154: Milk system is switched on

- ☞ Clean the drip grid under running water with a brush.
- ☞ Reinsert the cleaned drip grid.
- ✓ The machine is clean and ready for use.

10.6.5 Starting scheduled cleaning (with ProCare)

The cleaning program is started in the Service menu. All actions required by the user are shown on the touch screen.

- ☞ A pending cleaning is displayed on the **Service menu** button.



Fig. 155: The **Service menu** button with pending cleaning

- ☞ Remove the drip grid for separate cleaning.
- ☞ Tap on the **Service menu**  button.
 - ✓ The Service menu opens.
- ☞ If the cleaning program is PIN-protected, enter the PIN configured for this purpose.
 - ✓ Authorization is granted.
 - ✓ The **Cleaning** button is now active.



- ☞ Tap on the **Cleaning** button.
 - ✓ The **Cleaning** screen opens with the menu items for the various cleaning types.
- ☞ Tap on the **Scheduled cleaning**  button.

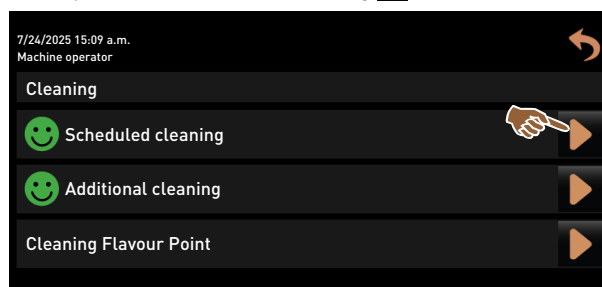

Fig. 156: Opening scheduled cleaning

- ✓ The Cleaning according to schedule dialog opens.

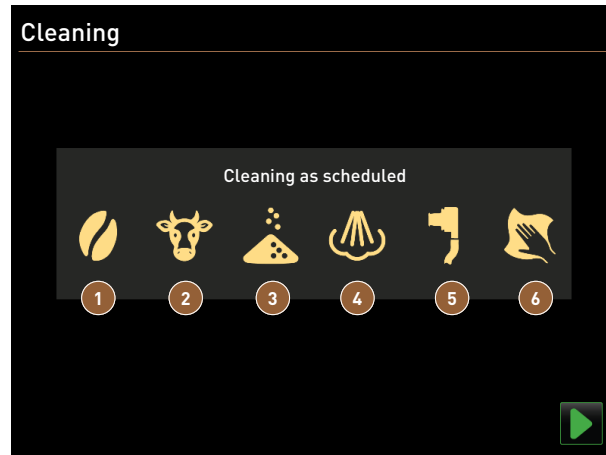



Fig. 157: Dialog for cleaning according to cleaning schedule

- | | |
|-----------------------------|---------------------------------------|
| 1 Cleaning of coffee system | 2 Cleaning of milk system |
| 3 Cleaning of powder system | 4 Cleaning of boiler system |
| 5 Plug & Clean cleaning | 6 Screen-guided manual cleaning steps |

- ☞ Start the scheduled cleaning with .
- ✓ Cleaning is started according to the set cleaning schedule.
- ✓ The systems to be cleaned are highlighted in the dialog with their icon.

Connecting Plug&Clean connection



Fig. 158: Connecting milk hoses to Plug&Clean connections

- ☞ Open the door of the cooling unit.
- ☞ Remove the milk hose(s) from the milk container.
- ☞ Connect the milk hose(s) to the respective **Plug&Clean** connections on the **ProCare** unit.

Screen-guided manual cleaning steps

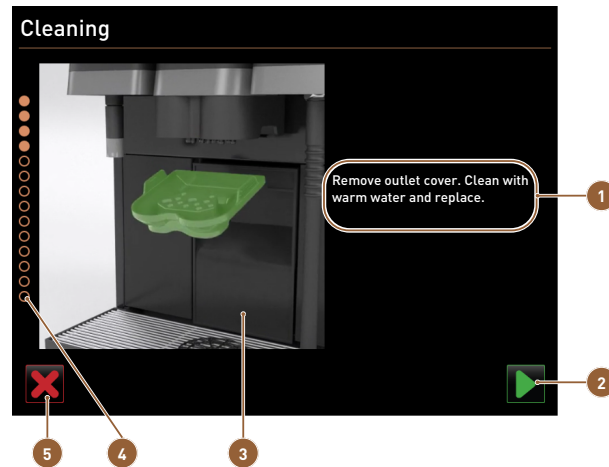

Fig. 159: Start dialogue for cleaning programme

- | | |
|--|--------------------------------|
| 1 Action request or information text | 2 Next button to the next step |
| 3 Image or animation of the current action | 4 Progress screen |
| 5 Button for cancelling cleaning | |

☞ Follow the instructions on the screen.

☞ After completing the activities shown on the screen, tap on  to go to the next cleaning step.

Manual cleaning: grounds container

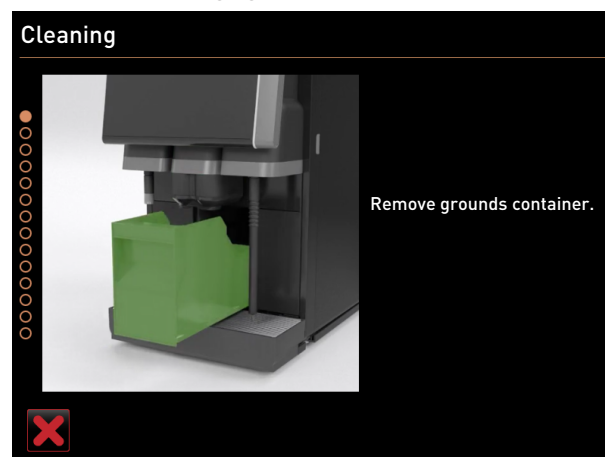

Fig. 160: Removing grounds container

☞ Push the beverage outlet upwards.

☞ Pull the grounds container out of the machine.

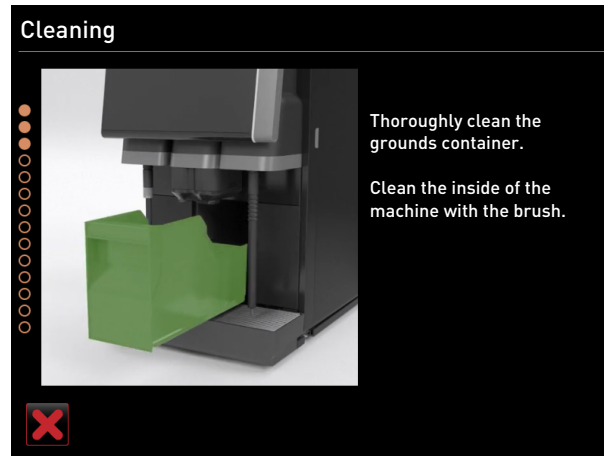

Fig. 161: Reinserting grounds container

- ✓ The instruction to thoroughly clean the grounds container, clean the machine interior with a brush and reinsert the grounds container appears.
- ☞ Wipe any remaining ground coffee out of the brewing chamber with the brush.
- ☞ Empty the grounds container and clean and rinse it with fresh water and detergent, then dry.
- ☞ Reinsert the grounds container into the cooling unit up to the stop.
- ✓ The **Remove beverage outlet cover** instruction appears.

Manual cleaning: beverage outlet cover

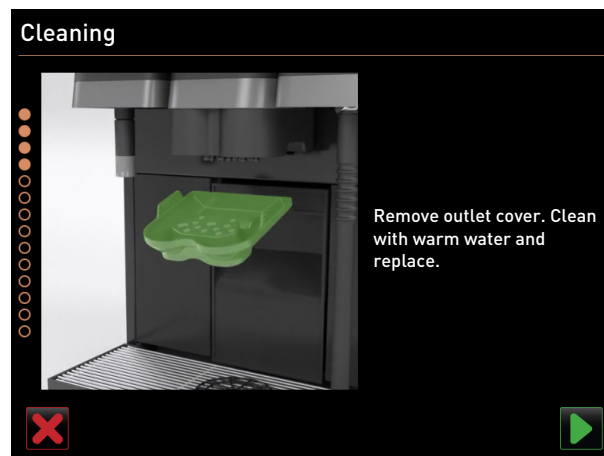



Fig. 162: Removing beverage outlet cover

- ☞ Release the beverage outlet cover by pressing it in the centre and pulling it down at the same time.
- ☞ Clean the beverage outlet cover under warm running water using a brush.
- ☞ **CAUTION! Risk of scalding from hot splashes during beverage dispensing!** An incorrectly inserted cover can result in splashing during beverage dispensing. Reinsert the cleaned cover by latching the cover in at the back and snapping it into place at the front.
- ☞ Check that the beverage outlet cover is correctly positioned.
- ☞ Use the  button to proceed to the next step.

Manual cleaning: mixing cup



Fig. 163: Lifting operating panel

- ☞ Unlock the operating panel at the top by pulling it firmly towards yourself.
 - ✓ The operating panel is unlocked.
- ☞ Push the operating panel upwards from below with both hands as far as it will go.
 - ✓ The operating panel is automatically held in the upper position.
 - ✓ The mixing cup is accessible.



Fig. 164: Pulling out mixing cup

- ☞ Pull the mixing cup out of the machine by the recessed grip.
- ☞ Confirm that the mixing cup has been removed with .

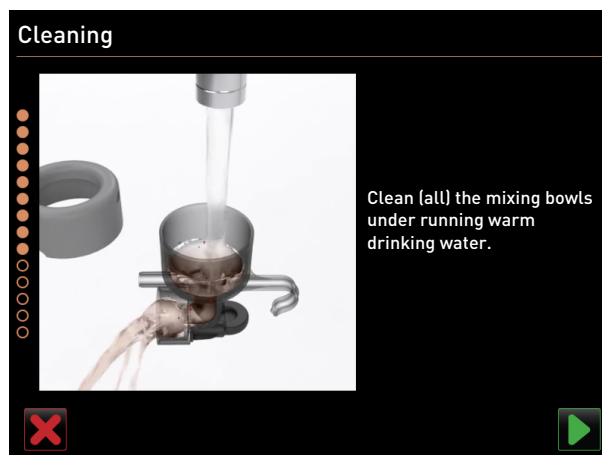



Fig. 165: Cleaning mixing cup

- ☞ Clean and rinse the individual parts of the mixing cup under clean, warm water.
- ☞ Wipe the mixing cup dry with a clean cloth.
- ☞ Confirm that the mixing cup has been cleaned with .

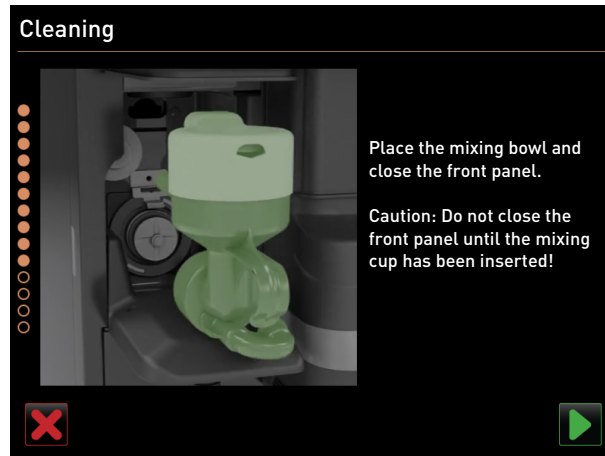



Fig. 166: Inserting mixing cup

- ☞ Reinsert the mixing cup.
- ☞ **NOTICE! Damage to the machine due to flooding!** An incorrectly inserted mixing cup can cause flooding.
Make sure the mixing cup is seated correctly.
- ☞ Close the operating panel again.
- ☞ Confirm that the mixing cup has been cleaned and inserted with .
- ✓ The cleaning process starts.

Progress display for automatic cleaning

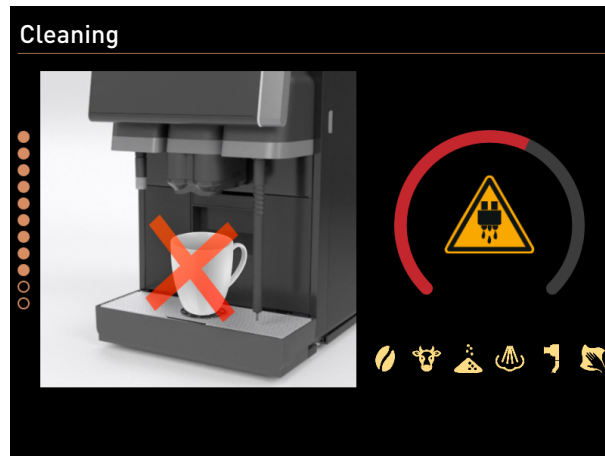

Fig. 167: Progress screen for cleaning

During cleaning, the screen shows the following:

- The crossed-out cup indicates that no beverages are available at this time.
- The progress circle indicates the completed and remaining cleaning process.
- A warning of hot escaping liquids is indicated by a warning symbol.
- The systems to be cleaned are highlighted with their icon.

Removing Plug & Clean connections



Fig. 168: Removing milk hoses from Plug & Clean connections

- ☞ Remove the adapter(s) of the milk hose from the respective **Plug & Clean** connection of the **Pro-Care** unit and wipe the adapter(s) with a damp cloth.

Reinserting milk container



Fig. 169: Inserting milk container

- ☞ Reinsert the cleaned milk container(s) into the cooling unit.
- ☞ Insert the milk tube adapter back into the cover of the respective milk container.
- ☞ If needed, fill with fresh and pre-cooled milk (3 °C – 5 °C or 37.4 °F – 41 °F).
- ☞ For machine equipment with **Twin Milk**: Refill both milk containers.
- ☞ Confirm connection of the milk container(s) with .
- ✓ The milk system is switched on.

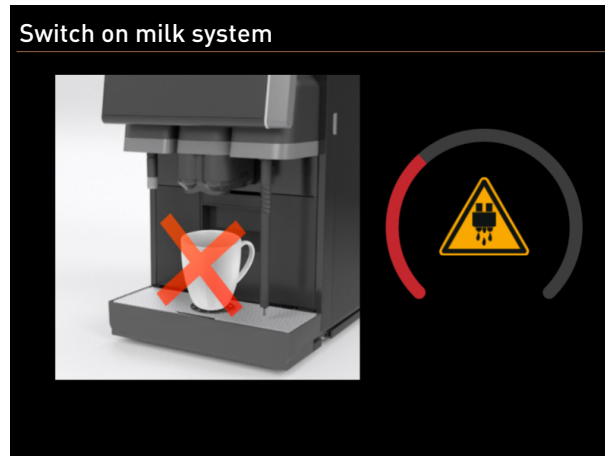

Fig. 170: Milk system is switched on

- ✓ The systems are rinsed.
- ✓ The system is reset.
- ✓ The next scheduled cleaning in hours [h] is displayed in the Service menu.







If the ProCare cleaning process, for whatever reason, was not completely and correctly completed, it must be repeated without fail. The machine can only be ready for use again if the cleaning process has been correctly completed.

Completion of planned cleaning

- ☞ Clean the drip grid under running water with a brush.
- ☞ Reinsert the cleaned drip grid.
- ☞ The machine is clean and ready for use.

10.6.6 Additional cleaning

Additional cleaning can be carried out at any time.

-  Coffee system
-  Milk system
-  Powder system
-  Boiler system
-  Milk connection hose piece (Plug & Clean, when cleaning with ProCare)
-  Manual cleaning (when cleaning with ProCare)

Starting additional cleaning

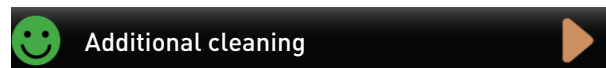

Fig. 171: Additional cleaning button

- ☞ Tap on the **Additional cleaning** button.
 - ✓ The screen with the available cleaning systems opens.

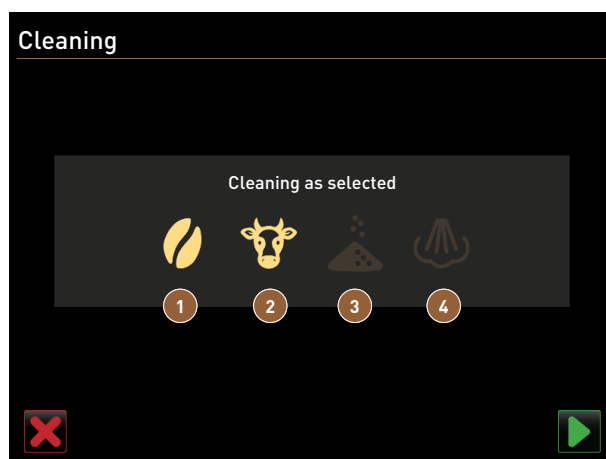

Fig. 172: Dialog for additional cleaning without ProCare

- | | |
|-----------------------------|-----------------------------|
| 1 Cleaning of coffee system | 2 Cleaning of milk system |
| 3 Cleaning of powder system | 4 Cleaning of boiler system |

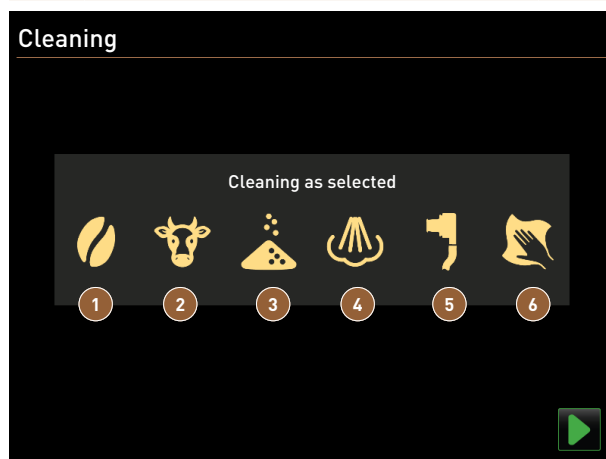



Fig. 173: Dialogue for additional cleaning with ProCare

- | | |
|-----------------------------|---------------------------------------|
| 1 Cleaning of coffee system | 2 Cleaning of milk system |
| 3 Cleaning of powder system | 4 Cleaning of boiler system |
| 5 Plug & Clean cleaning | 6 Screen-guided manual cleaning steps |

- ☞ Select the desired systems to be cleaned.
- ☞ Confirm your selection with .
- ☞ Follow the instructions on the machine screen.
- ✓ The selected systems are cleaned.

10.6.7 ProCare: Cleaning milk hose piece (Plug & Clean)

The milk hose piece (**Plug & Clean**) is cleaned at the end of the cleaning process.

You can start the **Plug & Clean** cleaning step manually at any time.

- ☞ To do this, connect the milk hoses to the ProCare milk connection (**Plug & Clean**).
- ✓ The following dialogue opens:



Fig. 174: Plug & Clean dialog

- ☞ Confirm cleaning on the screen with **OK**.



Fig. 175: Removing milk hoses from Plug & Clean connections

- ☞ When cleaning is complete, remove the adapter(s) of the milk hose from the respective **Plug & Clean** connection of the **ProCare** unit and wipe the adapter(s) with a damp cloth.

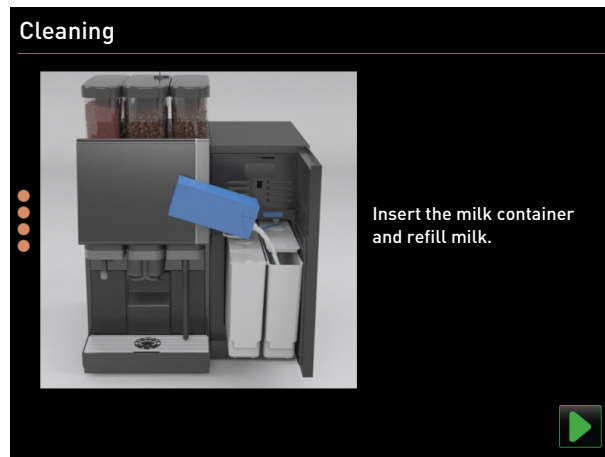



Fig. 176: Inserting milk container

- ✓ The dialogue with the instruction to insert the milk container(s) appears.
- ☞ Reinsert the cleaned milk container(s) into the cooling unit.
- ☞ Insert the milk tube adapter back into the cover of the respective milk container.
- ☞ If needed, fill with fresh and pre-cooled milk (3 °C – 5 °C or 37.4 °F – 41 °F).
- ☞ Confirm connection of the milk container(s) with .

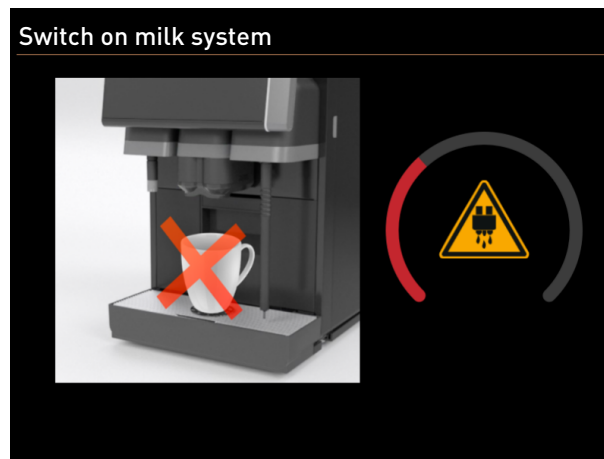

Fig. 177: Milk system is switched on

- ✓ The **Switch on milk system** status screen appears.
- ✓ The system is reset.
- ✓ The machine is clean and ready for use.

10.6.8 Display-guided cleaning: Flavour Point

The Flavour Point is an equipment variant.



⚠ CAUTION

Risk of scalding due to hot water!

There is a risk of scalding at the hot water dispensing points.

Before cleaning, hot water is dispensed into the cleaning container.

- ☞ Do not reach under the dispensing points when dispensing hot water.
- ☞ Position the cleaning container for cleaning in such a way that it cannot be knocked over.



⚠ CAUTION

Risk of scalding from hot cleaning container!



During Flavour Point cleaning, the cleaning container is filled with hot water. Touching the hot cleaning container poses a risk of scalding.

- ☞ Wear gloves when cleaning the Flavour Point.



Have the following utensils ready before the cleaning program:

- Cleaning container with four hose adapters
- Clean and damp cloth

Before cleaning, the cleaning container is filled with hot water via the beverage outlet or optionally via the separate hot water outlet.

Starting cleaning sequence

Cleaning can be started with the **Caretaker** or **Machine operator** profile or by the service technician.

- ☞ Tap on the **Service menu**  button.
 - ✓ The Service menu opens.
- ☞ Tap on the  **Cleaning** button.
 - ✓ The screen for selecting a cleaning opens.

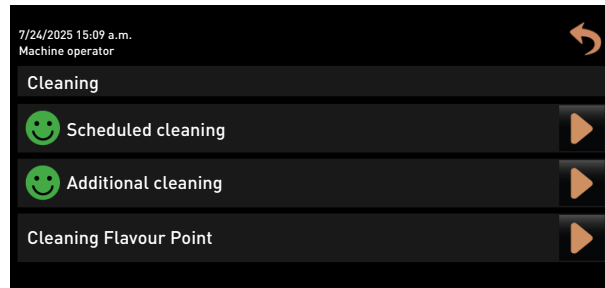

Fig. 178: Screen with selection of cleaning types



- ☞ Tap on the  Flavour Point cleaning button.
- ✓ The **Flavour Point cleaning** dialogue opens.



Fig. 179: Place cleaning container under the hot water outlet dialog

- ✓ The **Place cleaning container under the beverage outlet** instruction is displayed.
- ☞ Place the cleaning container under the hot water outlet or beverage outlet (for machines without a separate hot water outlet).
- ☞ Use the  button to proceed to the next step.

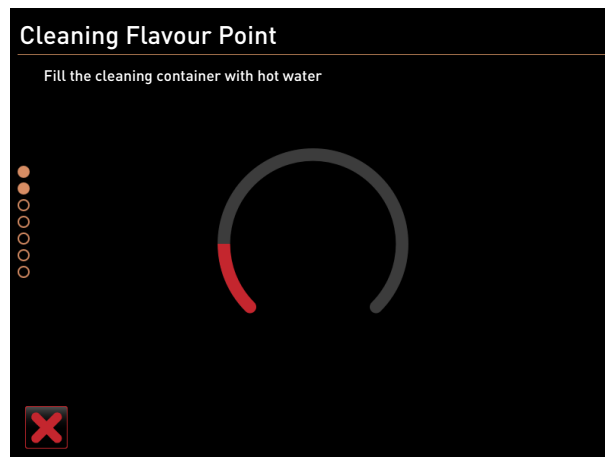

Fig. 180: Filling cleaning container with hot water

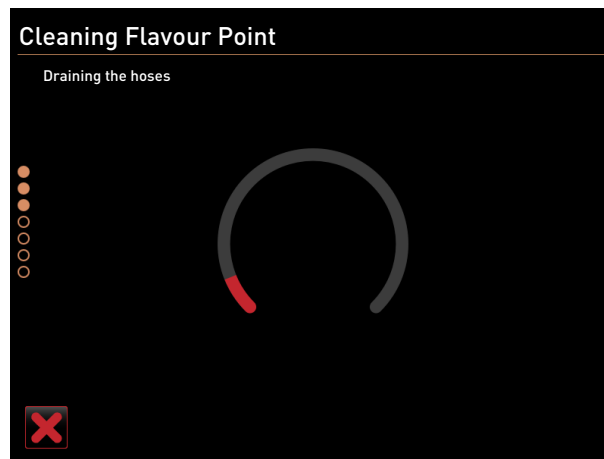

Fig. 181: Drain hoses

- ✓ The cleaning container is filled with hot water.
- ✓ The syrup hoses are then emptied automatically.

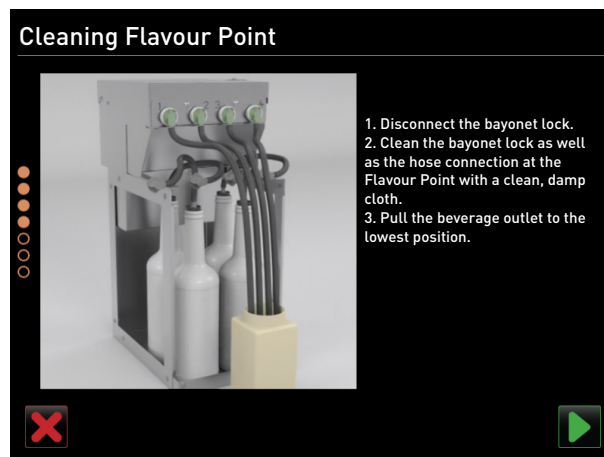



Fig. 182: Connecting cleaning container to Flavour Point

- ☞ Remove the bayonet locks on the Flavour Point.
- ☞ Clean the bayonet lock and connection to the Flavour Point using a clean, moist cloth.
- ☞ Connect cleaning container hoses to the Flavour Point.
- ☞ Pull the beverage outlet to the lowest position. With machines with automatic beverage outlet, the lowest position is set automatically.
- ☞ Start the cleaning process with the  button.

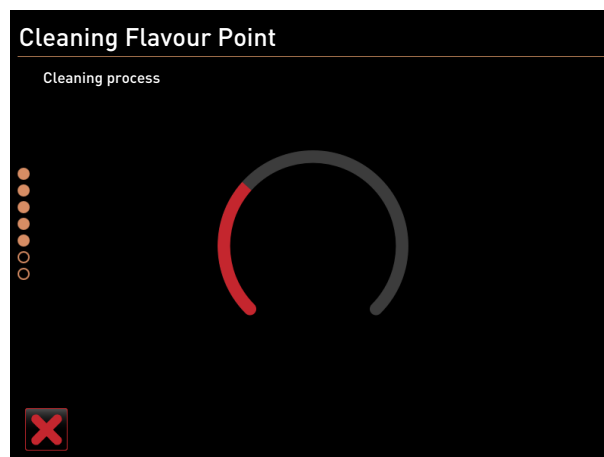

Fig. 183: Flavour Point cleaning process is running

- ✓ The cleaning process starts.
- ✓ In this step, the cleaning process lasts 5 to 10 min.

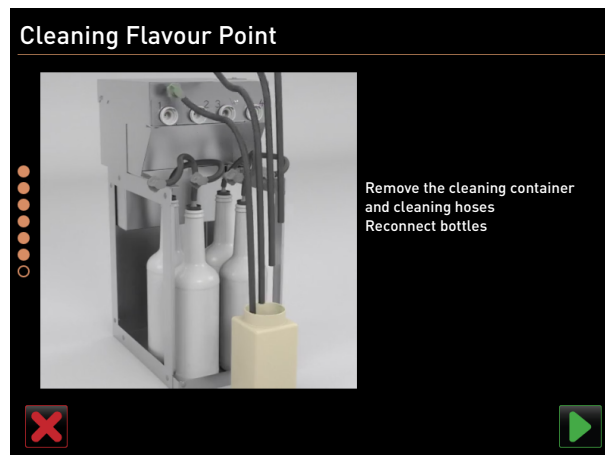

Fig. 184: Removing cleaning container again

- ☞ Remove the cleaning container and cleaning hoses.
- ☞ Reconnect the syrup bottles to the Flavour Point.
- ☞ Confirm the connection of the syrup bottles with the button.
- ✓ The cleaning process switches to the **Refill flavour** mode.



Fig. 185: Filling of syrup hoses

- ☞ Tap on the **Start pump** button for syrup 1.
 - ✓ Syrup hose 1 is filled.
 - ✓ The button label changes to **Stop pump**.
 - ✓ After a few seconds, the label changes back to **Start pump** and the button for the next pump is active.
- ☞ Repeat the process with syrup 2 to 4.
 - ✓ All syrup hoses are filled again.
 - ✓ Flavour Point cleaning is now complete.
- ☞ Close the cleaning process with the button.
- ✓ The **Flavour Point cleaning** dialogue closes.
- ✓ The machine is restarted.
- ✓ After restarting, the machine with the Flavour Point is ready for operation.

10.7 Cleaning schedule



Compliance with HCCP cleaning concept

Manual adjustments by the service technician that deviate from the cleaning schedule should meet the requirements for the HACCP cleaning concept.

If no cleaning schedule is configured or cleaning is configured with an instruction, the operator is responsible for carrying out the necessary cleaning.

The service technician can make the following settings in the **Cleaning schedule**:





- System to be cleaned
- Configuration of cleaning day
- Setting of the cleaning level and the start of cleaning
- Starting time of a cleaning
- Setting of the time window before/after cleaning

See also

📖 Cleaning regulations and conditions [▶ 116]

10.7.1 Calling up cleaning schedule

A standard cleaning schedule is stored in the machine. The cleaning schedule can also be customised by service technicians.

- ☞ Tap on the **Service menu**  button.
 - ✓ The Service menu opens.
- ☞ Tap on the **Log-out** button  and back on **Log-in** .
- ☞ Log in as a service technician with the corresponding PIN.
- ☞ Tap on the **Settings**  button.
 - ✓ The **Settings** opens right away with the system settings.

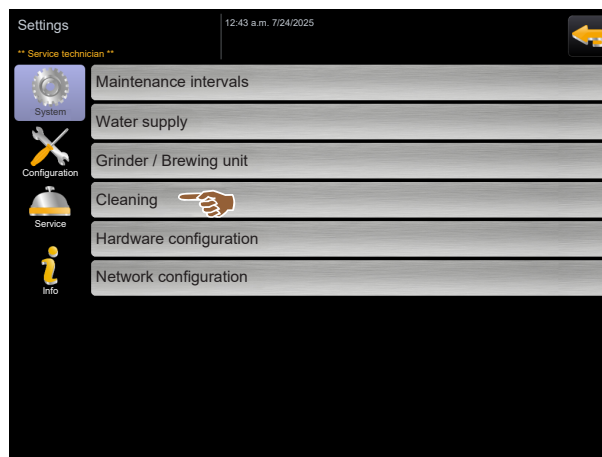

Fig. 186: Call up of cleaning settings

- ☞ Click on the **Cleaning** button.
 - ✓ The screen with the cleaning settings appears.

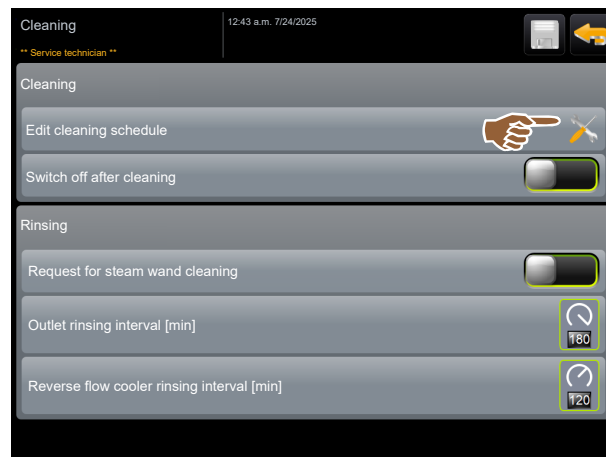

Fig. 187: Screen with the cleaning settings

- ☞ Click on the **Edit cleaning schedule** button.
- ✓ The schedule for the cleaning tasks appears.

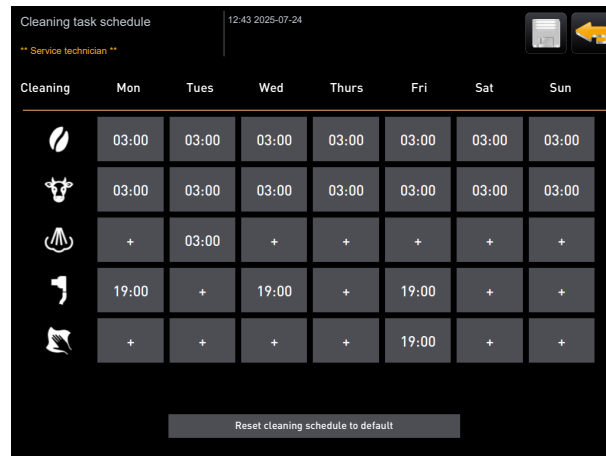

Fig. 188: Cleaning task schedule

10.7.2 Setting cleaning times

Default times are predefined for the cleaning work schedule. If a customized cleaning schedule has been created, it can be reset to the default schedule at any time. If a customised cleaning schedule has been reset to **Default**, this cannot be undone.

Cleaning schedules are set for different systems on the **Cleaning schedule for cleaning tasks** screen (global settings). Cleaning schedules can be set to daily or on different days of the week at different time intervals.

The following systems can be cleaned:

- Coffee system
- Milk system
- Powder system
- Boiler system
- Plug & Clean system (with ProCare)

Adding cleaning task

- ☞ In the table with the cleaning tasks, tap on the plus sign in the desired empty field.
- ☞ The dialog for adding a cleaning task opens.

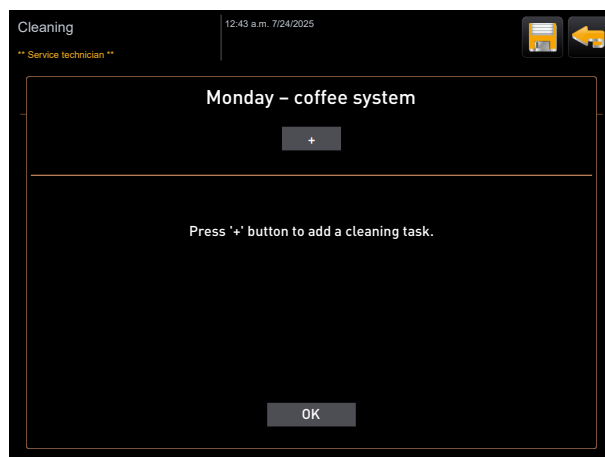

Fig. 189: Creating cleaning task

- ☞ Tap on the plus sign.
- ☞ The dialog with the settings appears.
- ☞ Configure the cleaning task as shown in the following description.

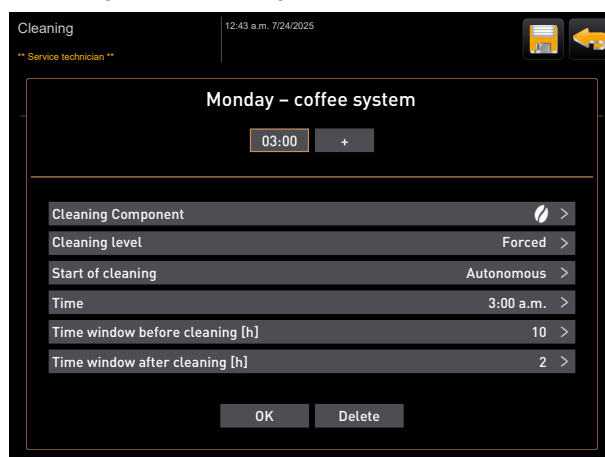

Fig. 190: Selecting settings for cleaning task

Setting cleaning stage

Two cleaning stages are possible:

- **Instruction** = The coffee machine is still ready for use.
- **Forced** = The coffee machine is blocked.

- ☞ Tap on the **Cleaning stage** line.
- ☞ Confirm the selection with the **OK** button.
- ☞ The cleaning stage is saved.

Defining start of cleaning

There are two different ways of starting a cleaning process:

- **Automatic** = Cleaning starts automatically without operator intervention.
- **Manual** = Cleaning only starts with operator intervention.

- ☞ Tap on the Start of cleaning line.
- ☞ Confirm the selection with the **OK** button.
- ☞ The start of cleaning is defined.

Setting time

You can define up to four times.

- ☞ To do this, tap on the plus sign next to the time.
- ☞ Tap on the **Time** line.
- ☞ The dialog with the settings appears.

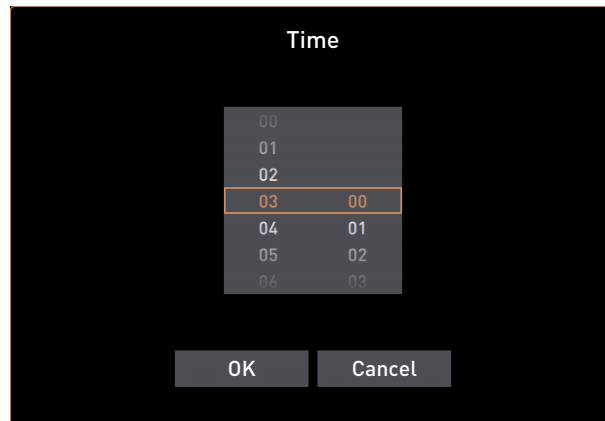

Fig. 191: Selecting time for cleaning

- ☞ Scroll to select the time.
- ☞ Confirm the selection with the **OK** button.
- ☞ The selected time appears in the dialog.
- ☞ Confirm the selection with the **OK** button.
- ☞ The time is saved.

Defining a time window before and after cleaning

The **Time window before cleaning [h]** defines the time before a planned cleaning in which you can push forward this planned cleaning.

The **Time window after cleaning [h]** defines the time after a planned cleaning in which you can make up a cleaning before the machine is blocked (grace period).

The **Time window before cleaning [h]** and **Time window after cleaning [h]** can be used to postpone a scheduled cleaning cycle.

Example: A large number of customers are expected at the time of the planned cleaning. This can be avoided with the time window before and after cleaning.

- ☞ Tap on the **Time window before cleaning [h]** or **Time window after cleaning [h]** line.
- ☞ The dialog for selecting the hours, similar to that for the time, is displayed.
- ☞ Scroll to set the time window.
- ☞ Proceed as when setting the time.
- ☞ The hours for the respective time window are displayed in the dialog.

Editing existing cleaning task

- ☞ On the **Cleaning schedule for cleaning tasks** screen, select a system and the days of the week on which cleaning is to be carried out and tap on the desired time.
- ☞ The dialog with the settings appears.
- ☞ Edit the desired settings.

10.8 Manual cleaning

Various components have to be cleaned manually.

10.8.1 Manual grounds container



CAUTION

Health problem due to mold growth in the grounds container!

Coffee grounds in the grounds container can quickly lead to mold growth. If the mold spores spread into the machine, there is a risk of contamination of the coffee. Contaminated coffee can cause health problems.

☞ Clean the grounds container daily.



NOTE

Property damage to the grounds container due to high temperatures!

Cleaning at high temperatures can cause damage.

☞ Do not clean the grounds container in the dishwasher.

Cleaning interval: Daily

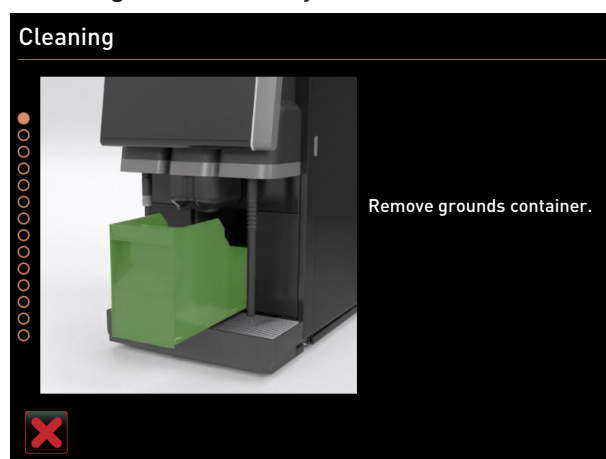

Fig. 192: Remove grounds container dialog

- ☞ Push the beverage outlet upwards (manual beverage outlet).
- ☞ Pull the grounds container out of the machine.
- ☞ Empty the grounds container.
- ☞ Clean the grounds container thoroughly with water and detergent.
- ☞ Rinse out the grounds container with clean water.
- ☞ Dry the grounds container with a clean cloth.
- ☞ Reinsert the grounds container into the cooling unit.
- ✓ The grounds container is empty and clean.

10.8.2 Cleaning brewing chamber

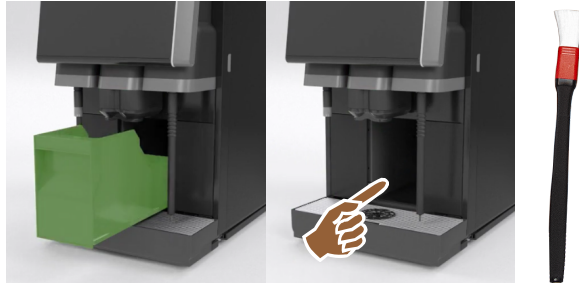

Fig. 193: Cleaning brewing chamber

- ☞ Push the beverage outlet upwards (with manual beverage outlet).
- ☞ Pull the grounds container out of the machine.
- ☞ Remove ground coffee in the machine brewing chamber using the supplied brush.
- ☞ Wipe the brewing chamber dry with a clean, moist cloth.
- ☞ Reinsert the grounds container.
- ✓ The brewing chamber is cleaned.

10.8.3 Cleaning drip tray and drip grid



CAUTION

Risk of scalding due to hot water!

During automatic machine rinsing, hot water runs out of the beverage outlet.

If cleaning is carried out without the display-guided cleaning program:

- ☞ Switch off the machine before cleaning the drip grid, the drip tray or the lower part of the beverage outlet.



NOTE

Property damage due to flooding risk!

A plugged waste water outlet in the drip tray causes overflowing of the drip tray.

Before cleaning and descaling:

- ☞ Check that the waste water outlet is flowing freely.
- ☞ Check the drainage speed of the waste water outlet.

Cleaning interval: Daily

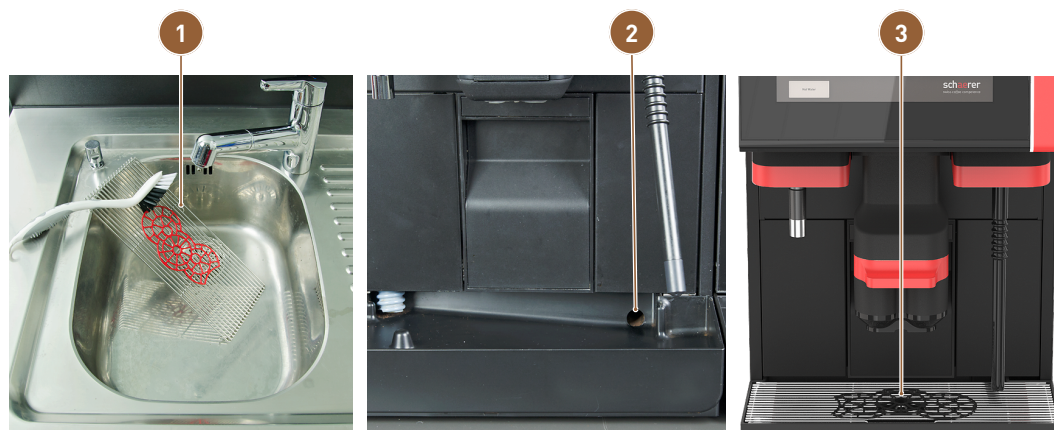

Fig. 194: Cleaning drip tray and drip grid

- | | |
|---|-----------------------------|
| 1 Drip grid with positioning aid | 2 Waste water outlet |
| 3 Positioning aid | |

- ☞ Remove the drip grid with positioning aid from the machine.
- ☞ Clean the drip grid with the positioning aid thoroughly under running water using dishwashing detergent.
- ☞ Rinse the machine drip tray with clean water.
- ☞ Check that the waste water outlet is flowing freely.
- ☞ Place the drip grid back into the drip tray and check that the drip tray is seated correctly.
- ☞ Check that the positioning aid is placed correctly opposite the beverage outlet.
- ✓ The drip tray and drip grid are clean.

10.8.4 Cleaning milk container



WARNING

Risk of infection from contamination!



Contamination and milk residues in the milk container can lead to infections. Infections can trigger health problems.

- ☞ Clean the milk container and cover before each filling.
- ☞ Wear protective gloves while cleaning.

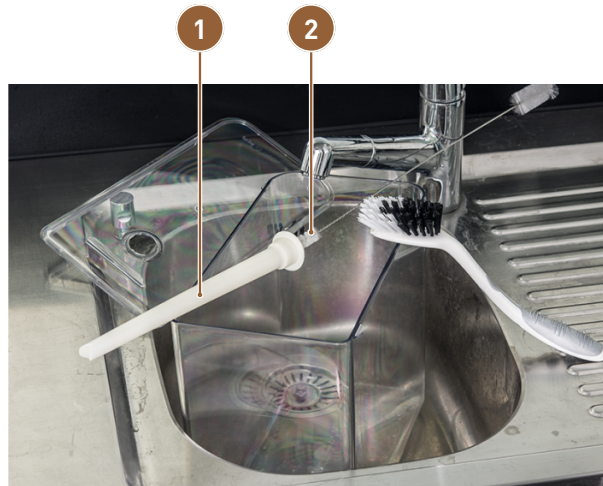

Fig. 195: Cleaning milk container

1 Riser pipe

2 Brush for riser pipe

Cleaning interval: Daily

- ☞ Remove the milk container from the cooling unit.
- ☞ Dispose of the remaining milk from the milk container.
- ☞ Observe the detailed cleaning instructions in the separate operating instructions for the optional accessories.
- ☞ Clean the milk container with fresh water, detergent and a clean, unused cloth.
- ☞ Clean the riser pipe with the supplied brush.
- ☞ Reinsert the milk container into the cooling unit.
- ✓ The milk container is cleaned.

10.8.5 Cleaning cooling unit



Fig. 196: Cleaning cooling unit

Cleaning interval: Daily

- ☞ Remove the milk container from the cooling unit.
- ☞ Wipe the inside of the cooling unit with fresh water and a fresh, unused cloth.
- ☞ Reinsert the milk container into the cooling unit.
- ✓ The cooling unit is cleaned.

10.8.6 Defrosting cooling unit



NOTE

Property damage and health problems due ice formation

Ice formation inside the cooling unit causes technical faults and high energy loss.

☞ As soon as there is a layer of ice in the interior, defrost the cooling unit.



NOTE

Property damage due to sharp objects!

The surface of the interior of the refrigerator can be damaged.

☞ Never use pointed or sharp objects to remove layers of ice.

☞ Always allow layers of ice to defrost.



Fig. 197: Defrosting cooling unit

Cleaning interval: As needed

- ☞ Switch the cooling unit off.
- ☞ Pull out the power plug.
- ☞ Open the front door and leave it open.
- ☞ Allow layers of ice to defrost.
- ☞ Wipe up any condensation with an absorbent cloth.
- ☞ Wait until the layer of ice has completely defrosted.
- ☞ Close the front door and switch the device back on or reconnect the power plug.
- ✓ The cooling unit is defrosted.

10.8.7 Clean touch screen



CAUTION

Risk of scalding from accidental beverage dispensing!

During cleaning, accidental beverage dispensing may result in scalding.

☞ Deactivate the touch screen in the Service menu before cleaning or switch off the machine.

**NOTE****Damage to the touch screen due to improper cleaning!**

Improper cleaning can scratch or otherwise damage the surface of the touch screen.

- ☞ Clean the touch screen with a moist cloth.
- ☞ Use soft cloths when cleaning.
- ☞ Do not use cleaning products or abrasive cleaners for cleaning.

Cleaning interval: Daily

- ☞ Tap on the **Service menu**  button.
 - ✓ The Service menu opens.

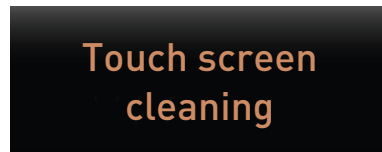

Fig. 198: Touch screen cleaning button

- ☞ Tap on the Touch screen cleaning button.
 - ✓ The touch screen is deactivated for 30 s and no longer reacts to touch.
 - ✓ A countdown appears.
- ☞ Clean the touch screen with a paper towel and commercially available glass cleaner during the available 30 s.
- ✓ After the countdown has elapsed, the touch screen becomes active again.
- ✓ The touch screen is cleaned.

10.8.8 Cleaning the steam wand**WARNING****Risk of infection from contamination of the steam wand!**

Contamination can lead to infections. Infections can trigger health problems.

- ☞ Wipe the steam wand with a clean, damp cloth after each use.
- ☞ Wear protective gloves while cleaning.

**CAUTION****Risk of burns from hot steam wand after steam has been dispensed!**

The steam wand is hot after dispensing steam.

- ☞ Only touch the steam wand at the designated places.

After every use

- ☞ Point the steam wand downwards towards the drip grid.
- ☞ Press the **Steam** button or, if available, the hardware button above the steam wand and allow steam to escape for approx. 2 s.
 - ✓ Milk residues in the steam wand are removed.

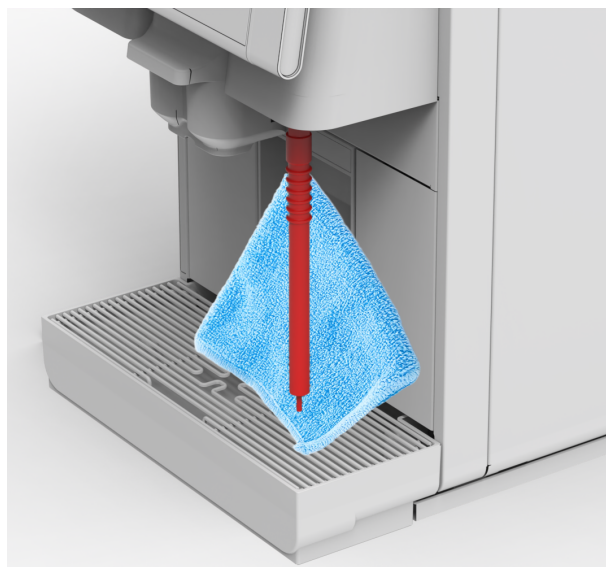

Fig. 199: Wiping milk remains off

- ☞ Wipe the milk remains off the steam wand using a clean, damp cloth.

Regular internal cleaning

The following cleaning steps apply to the steam wands for **Supersteam**, **Powersteam** and **Autosteam**.

- ☞ Carry out a cleaning as **After each use**.

Prepare steam wand for disassembly



NOTE

Property damage caused by excessive rotation of the steam wand!

If the steam wand is rotated beyond its swivel range, it may be damaged.

- ☞ Do not rotate the steam wand beyond the stop.
- ☞ Do not use force when rotating.

- ☞ Use a thick cloth to wrap around the steam wand.

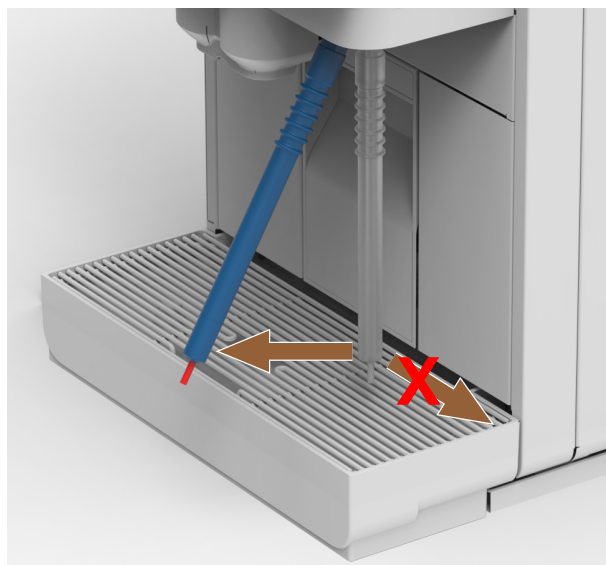

Fig. 200: Rotating steam wand to the front

- ☞ Rotate the steam wand to the front.

Prepare cleaning mixture

- ☞ Pour 0.5 l of fresh water into a suitable shallow cleaning bowl.
- ☞ Measure 25 ml of **special milk cleaning liquid** (art. no.3345340000) cleaning solution using a measuring cup.
- ☞ Add the measured cleaning solution to the water cleaning bowl.

Disassemble steam wand

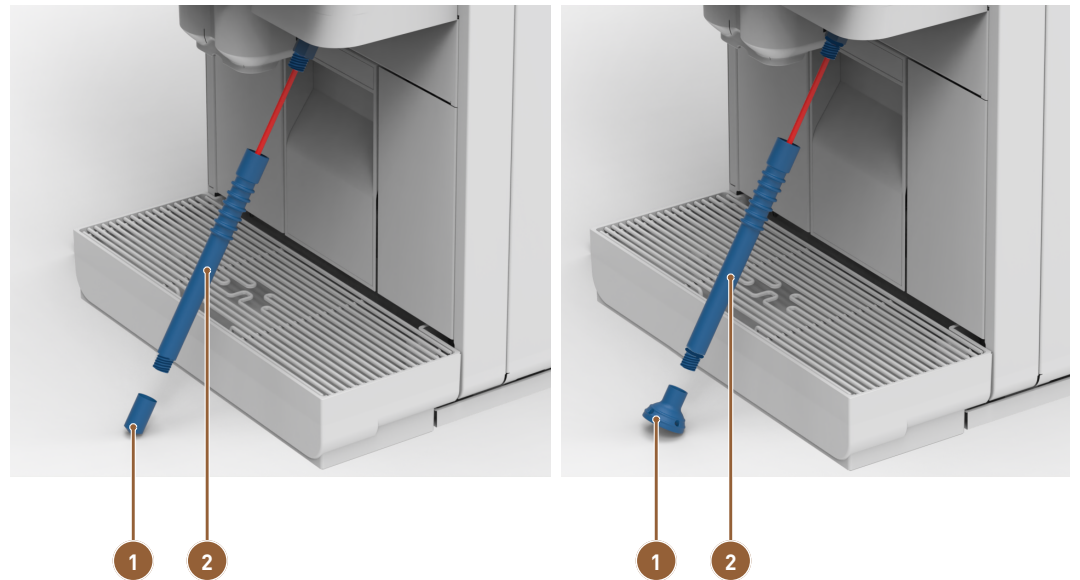

Fig. 201: Supersteam steam wand (left), Powersteam steam wand (right)

1 Steam nozzle

2 Steam pipe

- ☞ Unscrew the steam nozzle from the steam pipe.
- ☞ Unscrew the steam pipe.

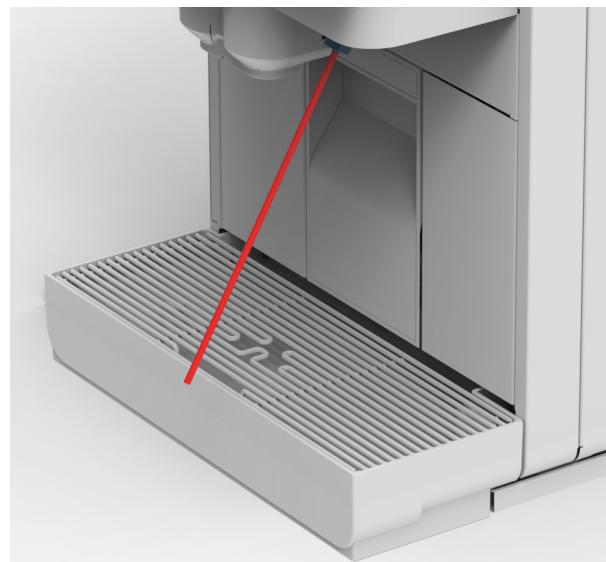

Fig. 202: Steam probe

- ✓ The steam probe is exposed.

Cleaning procedure



NOTE

Property damage due to excessive force!

The steam probe can be bent or break out of the rotating mechanism.

👉 Avoid using excessive force when moving the steam probe.

- ☞ Carefully wipe the exposed steam probe from top to bottom with a clean, damp cloth.
- ☞ Place the steam nozzle and the steam pipe in the water bath with cleaning solution for approx. 10 min.
- ☞ Then remove any milk remains from the steam pipe with a brush.
- ☞ Rinse the steam nozzle and the steam pipe under running water.
- ☞ Screw the steam nozzle and the steam pipe together.
- ☞ Carefully slide the steam pipe over the steam wand.
- ☞ Screw the steam pipe to the swivel joint.

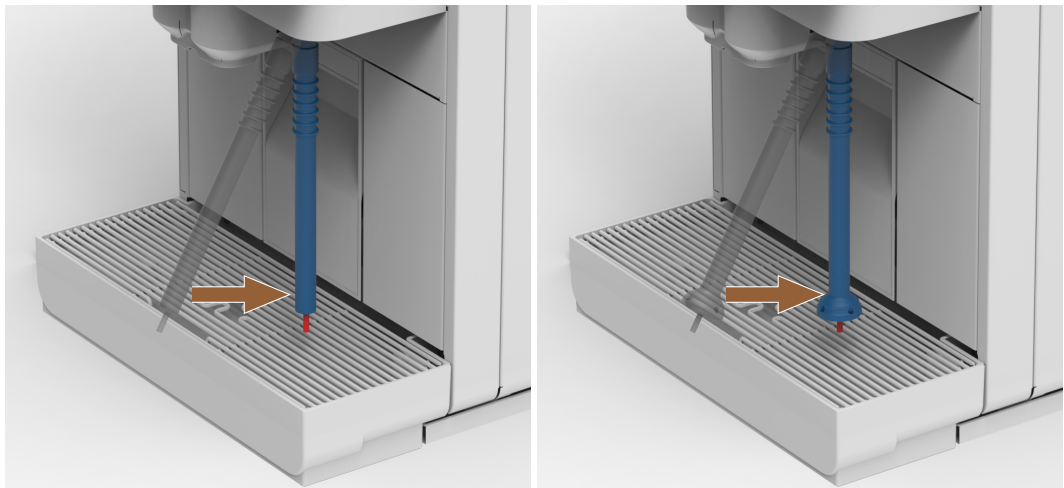

Fig. 203: Supersteam steam wand end position (left), Powersteam steam wand end position (right)

- ☞ Swivel the steam wand back to the initial position.
- ☞ Press the **Steam** button and allow steam to escape for approx. 2 s to remove cleaning solution residue in the steam wand.
- ☞ Repeat the short steam dispensing process two or three times.
- ☞ Wipe the steam wand with a clean cloth.
- ✓ Interior cleaning is complete.

10.8.9 Cleaning external drinking water tank



WARNING

Risk of poisoning from cleaning products!

Residues of cleaning products in the drinking water tank can cause poisoning.

👉 Never add cleaning products to the drinking water tank.

WARNING
Risk of infection from contamination!

Contamination can lead to infections. Infections can trigger health problems.

☞ Wear protective gloves while cleaning.



Fig. 204: External drinking water tank

Cleaning interval: Daily

- ☞ Unscrew the cover of the external drinking water tank.
- ☞ Pull the machine drinking water hose out of the external drinking water tank and the cover.
- ☞ Place the end of the drinking water hose on a clean cloth.
- ☞ Rinse the external drinking water tank thoroughly with fresh water multiple times. Do not use cleaning products.
- ☞ Clean the cover of the external drinking water tank with fresh water and dry it with a clean cloth.
- ☞ Fill the external drinking water tank with fresh water.
- ☞ Check that the floater moves freely (fill level monitoring).
- ☞ Lead the water hose back through the cover and into the external drinking water tank.
- ☞ Close the external drinking water tank with the cover.
- ✓ The external drinking water tank is cleaned.

10.8.10 Cleaning external waste water tank

WARNING
Risk of infection from contamination!

Contamination can lead to infections. Infections can trigger health problems.

☞ Wear protective gloves while cleaning.



Fig. 205: External waste water tank

Cleaning interval: Daily

- ☞ Unscrew the cover of the waste water tank.
- ☞ Pull the machine waste water hose out of the waste water tank and the cover.
- ☞ Place the end of the waste water hose on a clean cloth.
- ☞ Rinse the external waste water tank thoroughly multiple times with fresh water. Do not use cleaning products.
- ☞ Clean the cover of the waste water tank thoroughly with fresh water.
- ☞ Dry the cover of the waste water tank with a clean cloth.
- ☞ Check that the floater moves freely (fill level monitoring).
- ☞ Guide the waste water hose back into the waste water tank through the cover.
- ☞ Close the waste water tank with the cover.
- ✓ The external waste water tank is cleaned.

10.8.11 Cleaning additional devices



Care and cleaning of the optional accessories is described in the separate operating instructions for the **under-machine cooling unit**, **cup warmer** and **Cup &Cool** optional accessories.

10.8.12 Cleaning bean hoppers



⚠ WARNING

Risk of crushing and cutting injuries from rotating grinding discs!



There is danger of crushing and cutting injuries due to rotating grinding discs in the grinder.

- ☞ Never reach into the bean hopper when the machine is switched on.
- ☞ Switch off the machine and disconnect the power plug before performing any work on the grinder.



CAUTION

Risk of injury from hair being drawn in



Very long hair could get stuck in the grinder head and get pulled into the machine.

☞ Always wear a hair net when exposing the grinder head.



NOTE

Damage to the machine surface due to improper cleaning!

Improper cleaning can scratch or otherwise damage the surface of the machine.

☞ Use soft cloths when cleaning.

☞ Only use mild cleaning products.

☞ Do not use strongly alkaline, alcohol-based or degreasing or abrasive cleaners.

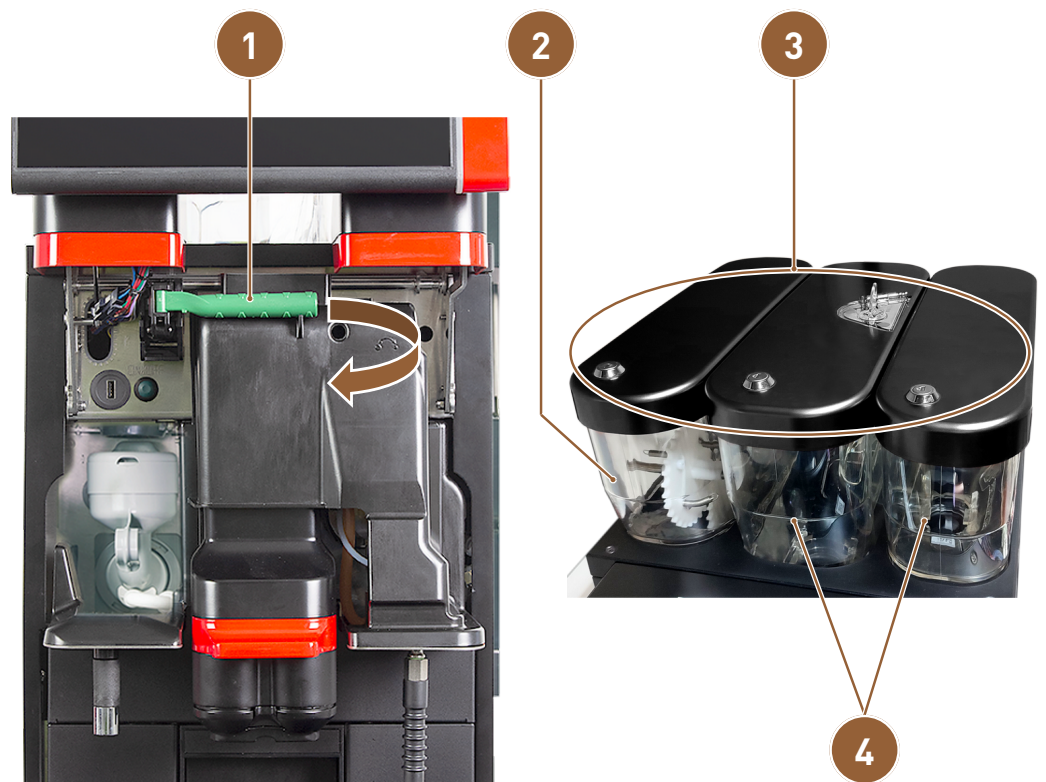

Fig. 206: Clean bean hoppers

- | | |
|--|---------------------------|
| 1 Central locking behind the user panel | 2 Powder container |
| 3 Closing devices (optional) for bean hoppers and powder container and for manual inlet | 4 Bean hoppers |

Cleaning interval: Weekly

☞ Tap on the **Service menu**  button.

✓ The Service menu opens.

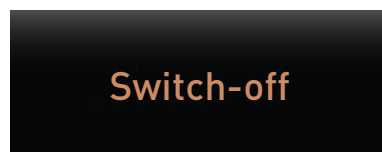

Fig. 207: Switch-off button

- ☞ Tap on the **Switch-off** button.
 - ✓ The machine is in Standby mode.
- ☞ Unlock the bean hoppers with the central locking mechanism behind the user panel.
- ☞ Lift the bean hoppers out of the machine.
- ☞ Remove the covers by opening the closing device for the cover, if present.
- ☞ Remove the remaining coffee beans from the machine and the bean hoppers.
- ☞ Clean the bean hoppers with a mild detergent and rinse them thoroughly under running water.
- ☞ Wipe the bean hoppers and cover dry with a clean cloth.
- ☞ Put the bean hoppers back into the machine.
- ☞ Lock the bean hoppers with the central locking mechanism.
- ☞ Fill the bean hoppers and put on the covers, close the closing device for the cover if present.
- ☞ Start the machine with the On/Off button.
 - ✓ The bean hoppers are clean.

10.8.13 Cleaning powder container



⚠ CAUTION

Risk of crushing due to rotating dosing screws!

The dosing screws inside the powder container rotate. There is a risk of crushing when reaching in.

- ☞ Switch the machine off before reaching into the powder container.



NOTE

Damage to the powder container due to improper cleaning!

Improper cleaning can scratch or otherwise damage the surface of the powder container.

- ☞ Do not use abrasive cleaners when cleaning.

The powder system can be equipped with a standard powder container for one powder or with a Twin powder container for two powders.

The design of the powder containers differs. The assembly and disassembly steps differ slightly.

Cleaning interval: As needed

Preparation

- ☞ Switch the machine off.
- ☞ Unlock the powder container using the central locking mechanism behind the user panel.
- ☞ Lift the powder container out of the machine.
- ☞ Remove the cover by opening the closing device, if present.
- ☞ Remove any remaining powder.
- ☞ Dismantle the powder container according to the following instructions (following chapters).
- ☞ Rinse the powder container and individual parts of the dosing mechanism thoroughly under running water.
- ☞ Allow all parts to dry thoroughly before reassembling.

See also

- 📖 Switching off [▶ 112]

10.8.13.1 Dismantling standard powder container

Overview

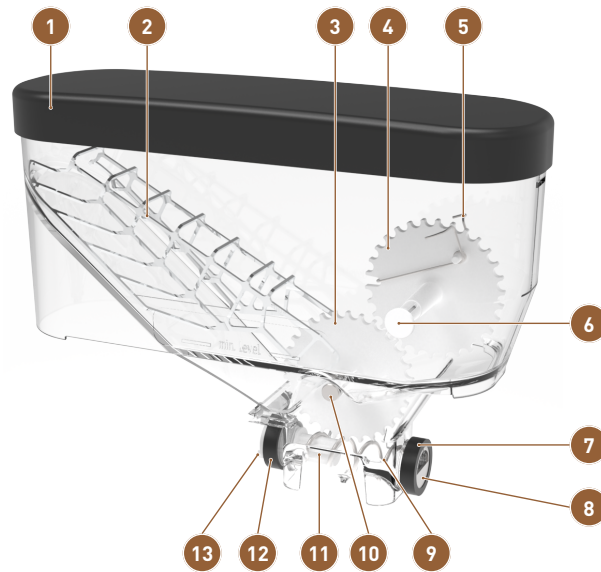

Fig. 208: Parts of the standard powder container (2 kg)

1 Cover	2 Powder scoop
3 Lower toothed wheel	4 Upper toothed wheel
5 Powder loosening unit	6 Locking for upper toothed wheel (rear axis not visible)
7 Cap nut for outlet restrictor	8 Outlet restrictor
9 Dosing screw	10 Axis for lower toothed wheel
11 Dosing screw holder	12 Cap nut for drive
13 Driver for drive	

Steps: dismantling powder container

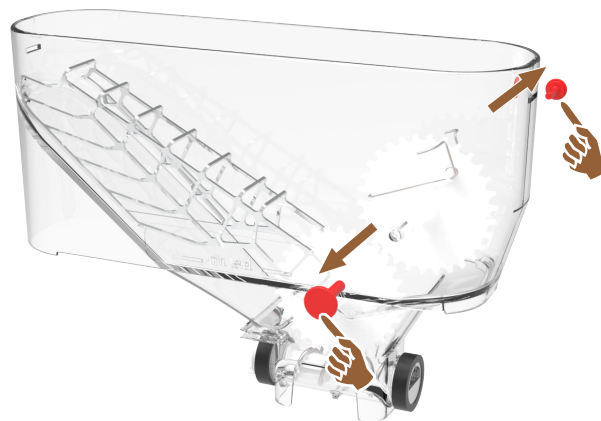

Fig. 209: Removing pin for upper toothed wheel

- ☞ Pull out the two locking pins on the right and left for the upper toothed wheel.
- ✓ The toothed wheel with the powder loosening spring is free.

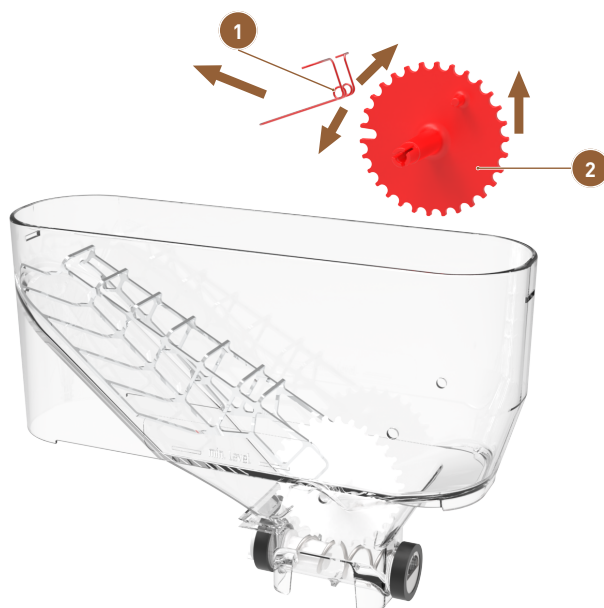

Fig. 210: Removing powder loosening unit

1 Powder loosening spring

2 Top toothed wheel for loosening powder

- ☞ Lift the toothed wheel out of the powder container with the powder loosening spring.
- ☞ Pull the eyelets of the spring apart slightly and remove the spring from the bracket on the toothed wheel.
- ✓ Toothed wheel and spring are separated.

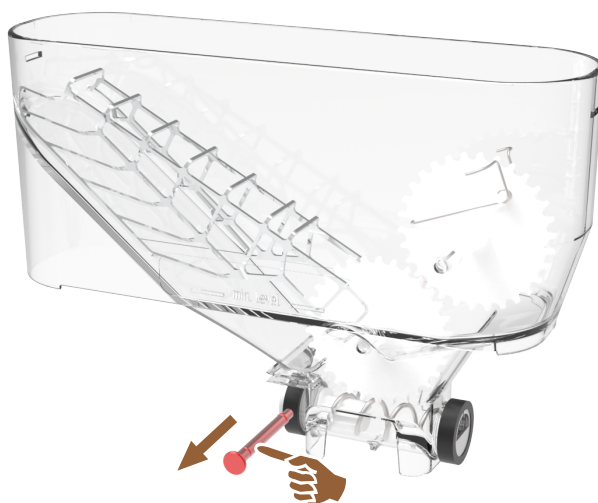

Fig. 211: Removing lower axle

- ☞ Press the axle for the lower toothed wheel out of the powder container.
- ✓ The lower toothed wheel with the powder scoop is free.

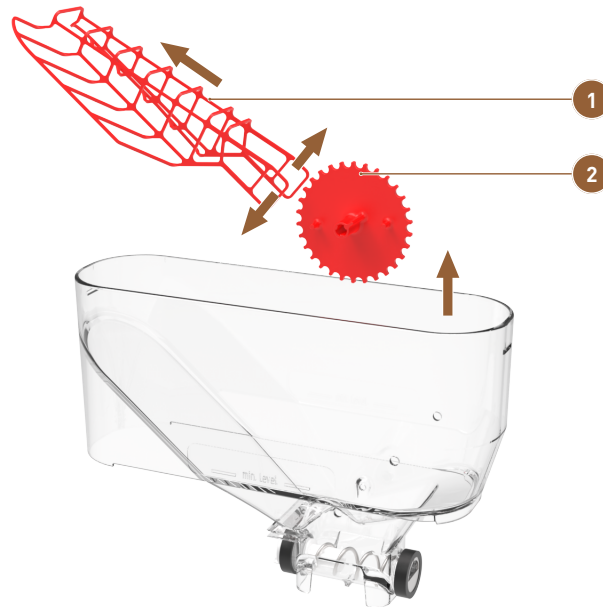

Fig. 212: Removing powder scoop

1 Powder scoop

2 Lower toothed wheel for powder scoop

- ☞ Lift the toothed wheel out of the powder container with the powder scoop.
- ☞ Pull the eyelets of the powder scoop apart slightly and remove the powder scoop from the axle bearing of the toothed wheel.
- ✓ Toothed wheel and powder scoop are separated.

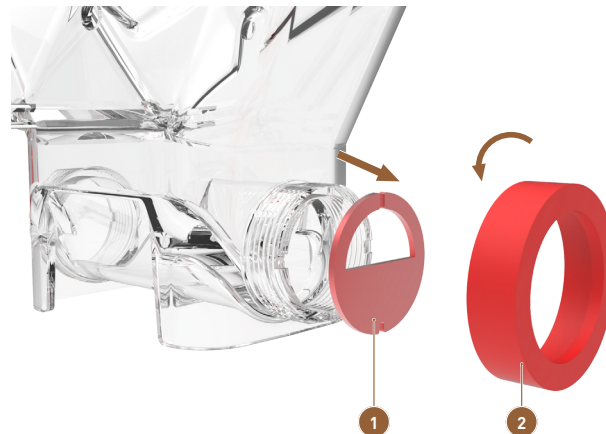

Fig. 213: Removing dosing element

1 Outlet restrictor

2 Cap nut for outlet restrictor

- ☞ Loosen the cap nut by turning it counterclockwise and then pull it off.
 - ☞ Remove the outlet orifice from the powder container.
- NOTICE! When reassembling, make sure that the dosing plate is correctly aligned and seated correctly in the lugs on the dispensing side.**
- ✓ The dosing elements are removed.

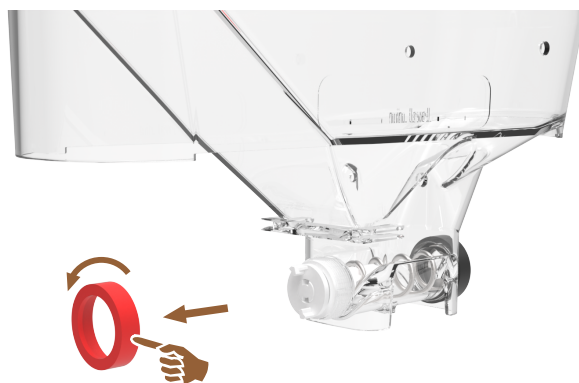

Fig. 214: Removing cap nut on feed side

- ☞ Loosen the cap nut by turning it counterclockwise and then pull it off.
- ✓ The supply unit can be removed.



Fig. 215: Removing supply unit

- ☞ Pull the feed unit out of the powder container.
- ✓ The powder container housing is empty.

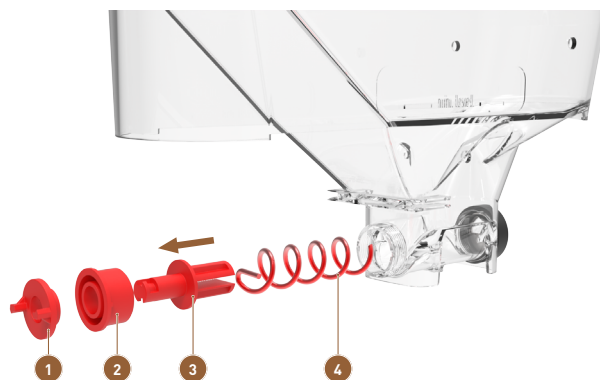

Fig. 216: Disassembling supply unit

- | | |
|-----------------------|-----------------------|
| 1 Driver | 2 Drive flange |
| 3 Screw holder | 4 Dosing screw |

- ☞ Turn the driver 90° to the left and pull it off the drive flange.
- ☞ Pull the drive flange off the screw holder.
- ☞ Pull the dosing screw off the screw holder.
- ✓ The entire powder container is disassembled and can be cleaned.

10.8.13.2 Dismantling Twin powder container

Overview

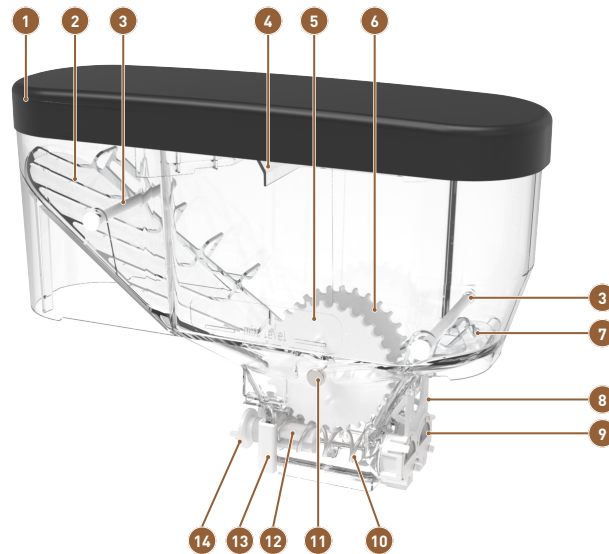

Fig. 217: Parts of the Twin powder container (2x 1 kg)

1 Cover	2 Powder scoop
3 Crossbar or bolt	4 Power filling aid
5 Toothed wheel for powder 1	6 Toothed wheel for powder 2
7 Powder loosening unit	8 Restrictor for Twin powder container
9 Powder container outlet restrictor	10 Twin dosing screw
11 Toothed wheel axis	12 Dosing screw holder
13 Drive holder for dosing screws	14 Driver for drive

Steps: dismantling powder container

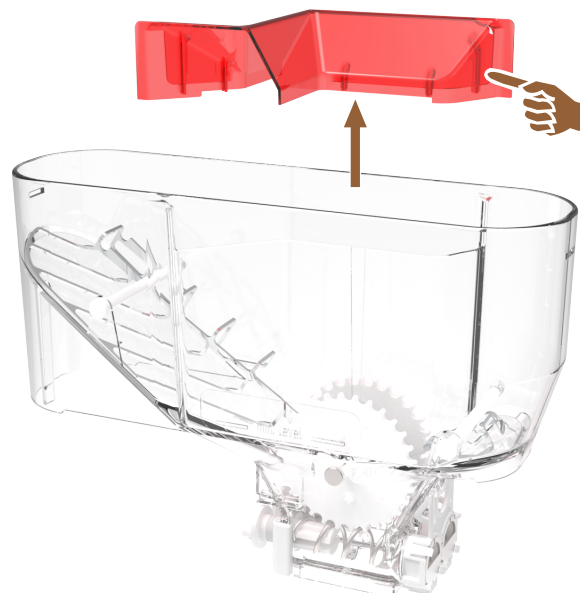

Fig. 218: Removing filling aid

- ☞ Remove the filling aid upwards from the powder container.

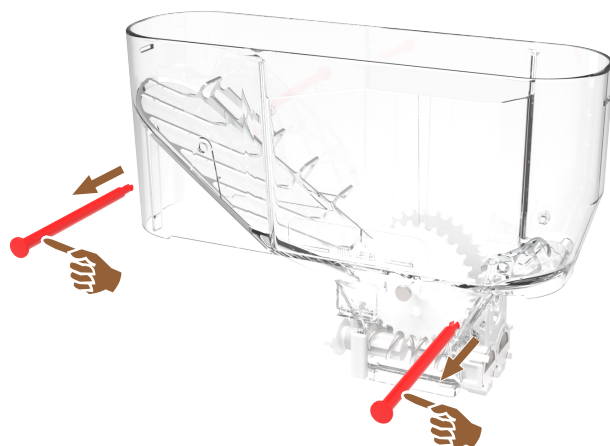

Fig. 219: Removing crossbars

- ☞ Press the locking lugs of the crossbars together and push both crossbars out of the powder container.
- ✓ The powder scoops are accessible.

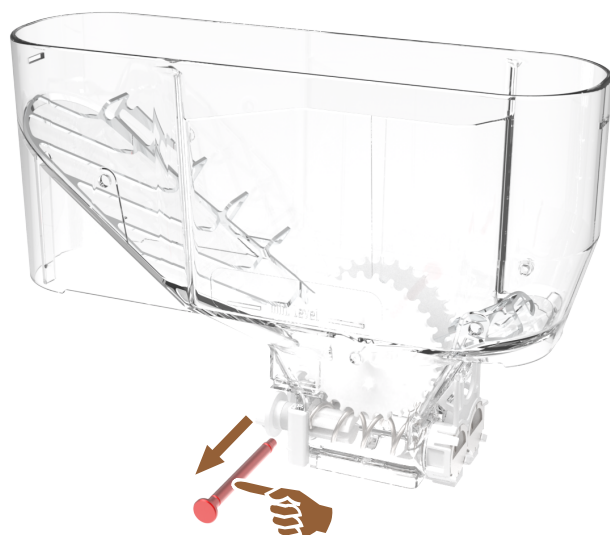

Fig. 220: Removing toothed wheel axis

- ☞ Press the common axle for both toothed wheels out of the powder container.
- ✓ The lower toothed wheels with the powder scoops are free.

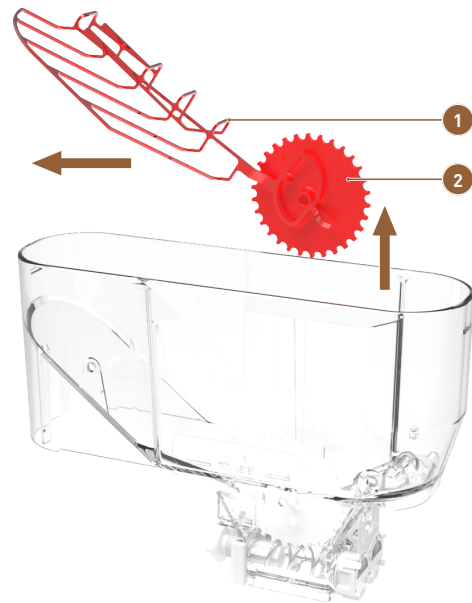

Fig. 221: Removing powder scoop and toothed wheel

1 Powder scoop

2 Right toothed wheel for powder scoop

- ☞ Lift the right toothed wheel out of the powder container with the powder scoop.
- ☞ Remove the powder scoop from the axle of the toothed wheel.
- ✓ Toothed wheel and powder scoop are separated.

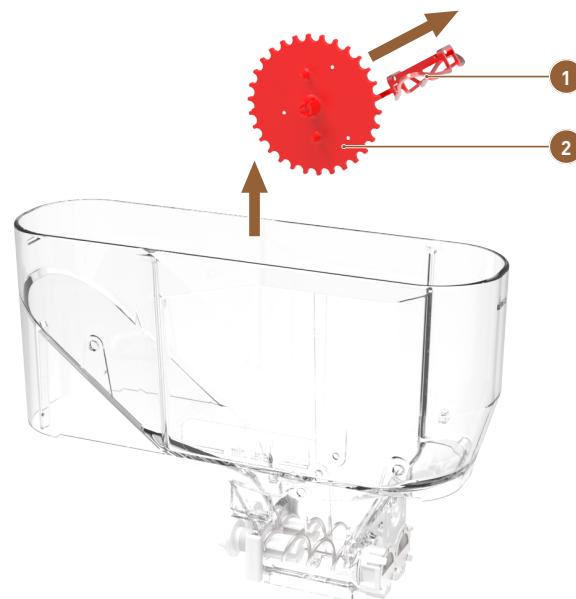

Fig. 222: Removing powder loosening unit

1 Left toothed wheel for loosening powder

2 Metal grid for loosening powder

- ☞ Lift the left toothed wheel out of the powder container with the short metal grid for loosening powder.
- ☞ Take the metal grid for loosening powder off the toothed wheel axis.
- ✓ Toothed wheel and metal grid are separated.



Fig. 223: Removing dosing element

- | | |
|--|--|
| 1 Restrictor with eyelets | 2 Guide groove on powder container |
| 3 Upper locking lugs for outlet restrictor | 4 Lower locking lugs for outlet restrictor |
| 5 Outlet restrictor | 6 |

- ☞ Press the eyelets of the dosing unit apart and pull them off the powder container.
- ☞ Pull the dosing unit horizontally out of the guide groove on the powder container.
 - ✓ The entire dosing unit is detached from the powder container.
- ☞ Press the upper locking lugs away from the outlet orifice.
- ☞ Press the lower locking lugs away from the outlet orifice and remove the outlet orifice.
 - ✓ The dosing unit is separated from the powder container and disassembled.

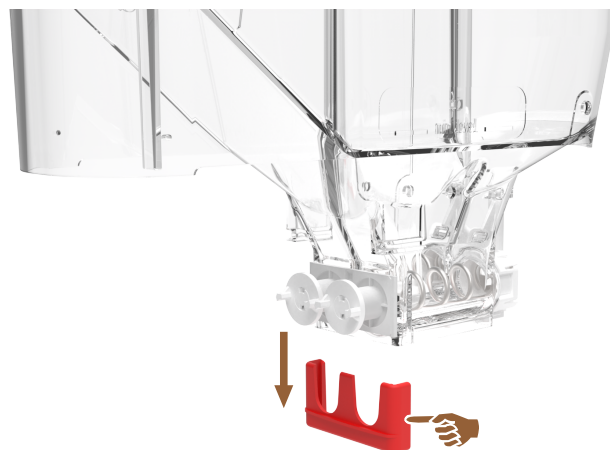

Fig. 224: Remove drive holder

- ☞ Press the bracket for the feed unit downwards away from the powder container.
 - ✓ The supply unit can be removed.



Fig. 225: Removing supply unit

- ☞ Pull the feed unit out of the powder container.

- ✓ The powder container housing is empty.

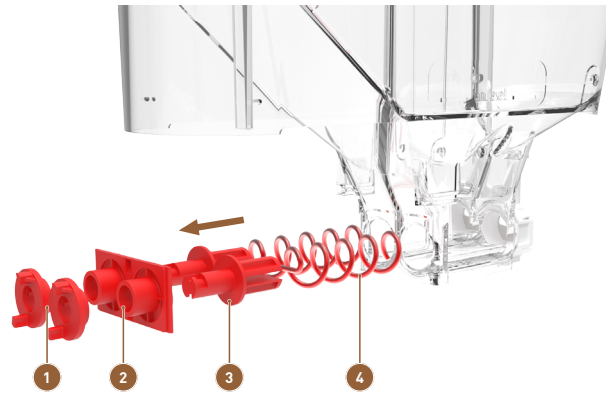

Fig. 226: Disassembling supply unit

1 Driver	2 Drive flange
3 Dosing screw holder	4 Dosing screw

- ☞ Turn both drivers 90° to the left and pull them off the drive flange.
- ☞ Pull the drive flange off the dosing screw holder.
- ☞ Pull the dosing screws off the dosing screw holders.
- ✓ The entire powder container is disassembled and can be cleaned.

10.8.13.3 Assembling powder hopper

- ☞ Reassemble the powder hopper in reverse order.
- ☞ Put the powder container in the machine.
- ☞ Replace the cover and close the closing device, if present.
- ☞ Lock the powder container using the central locking mechanism behind the user panel.
- ✓ The powder container is cleaned and reinserted into the machine.

10.8.14 Cleaning the lower part of the beverage outlet



CAUTION

Risk of scalding due to hot water!

During automatic machine rinsing, hot water runs out of the beverage outlet.

If cleaning is carried out without the display-guided cleaning program:

- ☞ Switch off the machine before cleaning the drip grid, the drip tray or the lower part of the beverage outlet.

If you carry out this cleaning step outside of the display-guided cleaning program:

- ☞ Tap on the **Service menu**  button.
- ✓ The Service menu opens.



Fig. 227: Switch-off button

- ☞ Tap on the Switch-off button.
- ✓ The machine is in Standby mode.

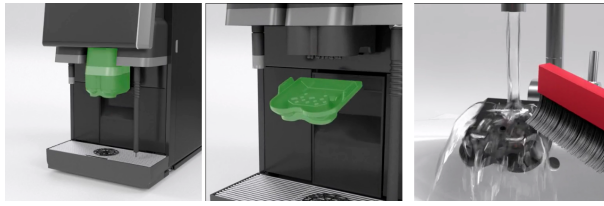

Fig. 228: Beverage outlet bottom cover removal

- ☞ Remove the cover of the beverage outlet at the front by releasing it (push and pull downwards).
- ☞ Clean the beverage outlet with water and a brush.
- ☞ Clean the lower beverage outlet under running water with a brush.
- ☞ Mount the cover to the beverage outlet by inserting it into the rear and clipping it into place at the front.
- ✓ The lower part of the beverage outlet is cleaned.

These steps only apply to cleaning outside of the display-guided cleaning program:

- ☞ Unlock the user panel and slide it upwards.
- ☞ Switch the machine on.
- ☞ Close the user panel by lifting it slightly until it disengages and pressing it down until it engages.

10.8.15 Clean outer surfaces



⚠ CAUTION

Cutting injuries from sharp edges on the housing base!



When cleaning the underside of the machine or the counter beneath the machine (if the machine feet are high), sharp edges on the housing base may cause cutting injuries.

- ☞ Wear gloves when cleaning the underside of the machine and the counter beneath the machine.



NOTE

Damage to the machine surface due to improper cleaning!

Improper cleaning can scratch or otherwise damage the surface of the machine.

- ☞ Use soft cloths when cleaning.
- ☞ Only use mild cleaning products.
- ☞ Do not use strongly alkaline, alcohol-based or degreasing or abrasive cleaners.

- ☞ Tap on the **Service menu**  button.
 - ✓ The Service menu opens.



Fig. 229: Switch-off button

- ☞ Tap on the **Switch-off** button.
 - ✓ The machine is in Standby mode.
- ☞ Wipe the outer surfaces of the machine and the optional accessories with a clean, damp cloth.
- ☞ Unlock the user panel and slide it upwards until it engages.
- ☞ Switch the machine back on using the switch-on button.

- ☞ Slightly lift the user panel and slide it back downwards until it engages.
- ✓ The machine is switched on and ready for use.

See also

- 📄 Clean touch screen [▶ 154]

11 Maintenance



WARNING

Risk of injury due to insufficient qualification!



Improper handling can lead to considerable personal injury and property damage.
Maintenance and safety-related activities may only be carried out by service staff.



WARNING

Health problems caused by heavy machine!

The weight of the machine exceeds the permissible load that a single person is allowed to lift or carry alone. The load of the machine may cause health problems when lifted or carried by a single person.



-  Do not lift or carry the machine alone.
-  Only lift or carry the machine with two people.



CAUTION

Risk of injury due to machine tipping over!

Improper lifting of the machine can cause it to tip. A tipping or falling machine can cause injury.



-  Do not lift the machine alone.
-  Only lift the machine with two people.



CAUTION

Risk of injury due to slipping!

Leaking liquid can lead to a wet floor around the machine. This can lead to injuries from slipping and falling.

-  Dry any spilled liquids on the floor immediately after spills occur.
-  Indicate large quantities of leaked liquid on the floor with a mobile warning sign.

The machine requires regular maintenance. This also includes safety-related activities.

With a few exceptions, the operator is not permitted to carry out maintenance and safety-related activities alone. For this type of maintenance or safety-related work, the service partner authorized by the manufacturer must be commissioned immediately. The service partner carries out all necessary work on the machine.

As soon as the time for maintenance or safety-related work is reached, the machine indicates this on the display. The machine can continue to operate normally.

The time of maintenance depends on various factors, but mostly on the utilization of the machine and the service life of the safety valves if present.

The safety valves must be replaced every two years if present.

11.1 Maintenance intervals



NOTE

Property damage due to maintenance intervals not upheld!

Postponed maintenance can lead to premature wear.

🔧 Have pending maintenance work carried out by service partners as soon as possible.

The maintenance intervals are defined in the separate maintenance regulations.

Safety-relevant components	24 months	48 months	72 months
Hot water boiler	Check (only replace if needed)	Replace	Check (only replace if needed)
Steam boiler	Check (only replace if needed)	Replace	Check (only replace if needed)
Safety valve 12 bar	Replace	Replace	Replace
Safety valve 5 bar	Replace	Replace	Replace

Prerequisites for maintenance:

- 🔧 If maintenance is due, contact the service partner.
- 🔧 Carry out all descaling intervals according to the instructions displayed by the machine.
- 🔧 Carry out descaling one day before maintenance work.

See also

📖 Descaling [▶ 178]

11.2 Performing maintenance and resetting counter

The **Maintenance interval** function is PIN protected (caretaker, machine operator, service technician).

- 🔧 Tap on the **Service menu** ⚙️ button.
 - ✓ The Service menu opens.

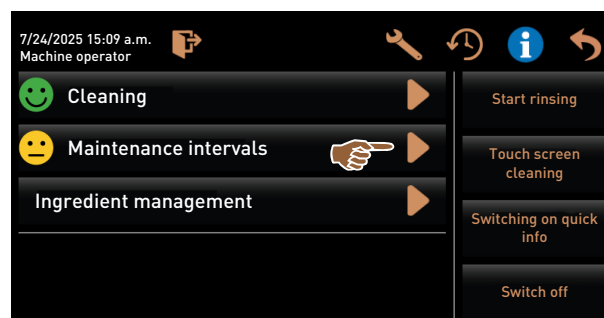

Fig. 230: Calling up maintenance intervals

The **Maintenance intervals** button shows the maintenance status of the machine with a smiley.

- Green smiley: The machine does not have to undergo maintenance.
- Yellow smiley: The machine has to undergo maintenance soon.
- Red smiley: The machine has to undergo maintenance.

- 🔧 Tap on the **Maintenance intervals** button in the Service menu.
 - ✓ The Maintenance intervals screen opens.

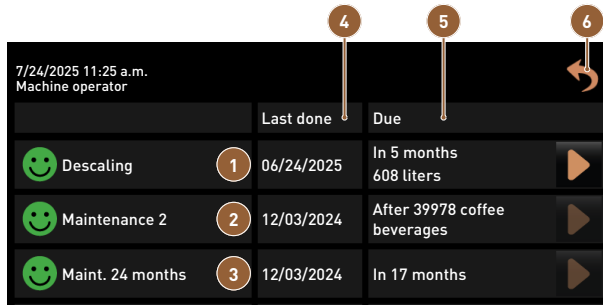

Fig. 231: Maintenance intervals screen

1 Descaling	2 Maintenance 2 by service technician
3 24-month maintenance by service technician	4 Last maintenance performed
5 Maintenance due	6 Back button

The ▶ button is used to start the pending **descaling** process.

The ▶ button displays a query for **maintenance 2** and **24-month maintenance**. The machine must undergo maintenance by a service partner in accordance with the separate maintenance regulations. Once maintenance has been completed, the query can be confirmed. The counter is reset.

In the **Last** column, the date on which the corresponding maintenance work was last carried out is displayed.

The **Due** column shows the time after how many months, beverages or liters the next maintenance work has to be carried out.

The **Back** button takes you back to the Service menu.



Fig. 232: Confirming maintenance

Performing and confirming maintenance

- ☞ Have the pending maintenance work carried out by a service technician.
- ☞ Then tap on the displayed maintenance task (1) or (2) to confirm it.
 - ✓ The dialogue for the corresponding maintenance tasks opens.



Fig. 233: Confirmation dialogue for completed maintenance work (example)

- ☞ Make sure that maintenance has been carried out and completed in accordance with the maintenance concept and maintenance checklist.
- ☞ Confirm the query with .
- ✓ The maintenance work is displayed as completed on the **Maintenance intervals** screen (green smiley).
- ✓ The date in the **Last** column changes to the current date.
- ✓ The date in the **Due** column updates based on the set intervals.

11.3 Replacing external water filter

The external water filter is an equipment variant.

The external water filter must be replaced by an authorized service partner/service technician once the programmed number of liters has been reached.



The **Supplementary Instructions for Water Quality** contain information on recording water values and the use of filter techniques. The supplementary instructions can be requested from the manufacturer or downloaded directly from the download portal.

12 Descaling

Descaling can be carried out independently by the operator.



WARNING

Risk of acid burns!



Acid escapes during the descaling process. Risk of skin irritation and severe eye irritation.



- ☞ Do not touch the descaling product with bare hands and read the enclosed safety data sheet.
- ☞ Wear protective gloves and goggles when descaling.
- ☞ For descaling with ProCare and milk system: Do not remove the milk hoses from the Plug & Clean connections during the descaling process. Wait for the instruction on the display.
- ☞ When descaling with a descaling cartridge: Do not remove the decalcification cartridge during the descaling process. Wait for the instruction on the display.
- ☞ When descaling with a descaling agent with an internal water tank: Do not remove the water tank with cleaning product and the vessel for collecting the cleaning liquid during the descaling process. Wait for the instruction on the display.



CAUTION

Risk of scalding due to hot water!

Hot water flows out of the hot water outlet and beverage outlet during descaling. This creates a risk of scalding.

- ☞ Slide a movable beverage outlet to the lowest dispensing position.
- ☞ Do not reach under the hot water outlet during the descaling process.



CAUTION

Risk of scalding from hot steam!

The steam wand emits hot steam during cleaning and descaling. There is a risk of scalding.

- ☞ Direct the outlet of the steam wand into the drip tray.
- ☞ Do not reach under the steam wand during the cleaning and descaling process.

Duration of descaling

A descaling process takes at least **85 minutes**. The machine is not ready for use during this time.

- ☞ Inform others in good time that the machine will not be ready for use.

Canceled descaling

The machine can only be ready for operation if the descaling process has been completed correctly. A descaling process that has not been fully and correctly completed must be repeated.

12.1 Required descaling material

The following items are required for descaling without ProCare:

- 1x Schaerer Uptime! decalcification cartridge
- 1x Schaerer cleaning container 1 l blue
- 1x Schaerer cover for cleaning container
- Gloves

- Protective goggles

12.2 Uptime! descaling cartridge



NOTE

Property damage due to incorrect descaling cartridge!

The coffee machine may be damaged if descaling cartridges other than those recommended by the machine manufacturer are used. Liability cannot be accepted for damages resulting from the use of other descaling agents, warranty claims become invalid.

- ☞ Only use descaling cartridges recommended by the machine manufacturer.
- ☞ Only use cartridges taken directly out of the packaging.
- ☞ Read the information on the packaging and the safety data sheet carefully before descaling. If no safety data sheet is available, request one from the sales partner.



Fig. 234: Uptime! decalcification cartridge

- Intended use: Descaling of coffee machine with mains water supply
- Scope of descaling: Descaling of boiler including hot water / steam system
- Application interval: Upon instruction

12.3 Checking waste water drainage



NOTE

Property damage due to flooding risk!

A plugged waste water outlet in the drip tray causes overflowing of the drip tray.

Before cleaning and descaling:

- ☞ Check that the waste water outlet is flowing freely.
- ☞ Check the drainage speed of the waste water outlet.

The following utensils are required to check the waste water outlet:

- 1 l water
- Clock with second hand

Checking waste water outlet drainage speed

- ☞ Remove the drip grid from the drip tray.
- ☞ Fill 1 l of water into the drip tray and check the timer at the same time.
- ✓ If the waste water outlet is clear, 1 l of water will drain completely within 30 s.



If 1 l of water does not flow out in the required time of 30 s, the waste water outlet is blocked. Descaling must not be carried out. The waste water outlet must first be repaired by a service technician.

12.4 “Descaling” screen

The following information is displayed on the screen during descaling:

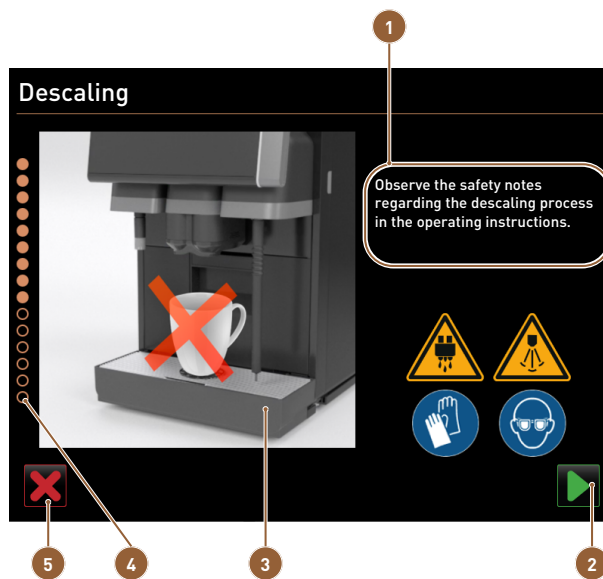

Fig. 235: Descaling screen

1 Area with information or instructions for action	2 Next button
3 Image or animation of the current action	4 Progress screen
5 Cancel button	

The **progress display** shows the progress of the descaling program. Filled circles show steps that have already been completed. Unfilled circles show steps that have not yet been completed.

The descaling program can be canceled at any time using the **Cancel** button. After descaling is aborted, the machine is not ready for use.

Images or animations for the current animation provide visual support for the information and instructions.

Information and instructions are provided in text form for each descaling step.

The **Next** button confirms instructions and takes you to the next step.

12.5 Performing descaling with descaling cartridge

- ☞ A pending descaling process is indicated by a yellow smiley in the Service menu.
- ☞ Tap on the **Service menu** button.
 - ✓ The Service menu opens.

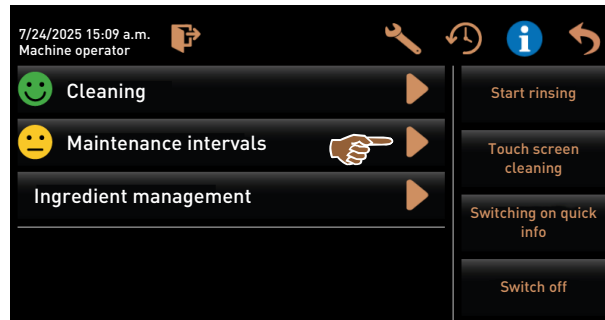

Fig. 236: Selecting maintenance intervals

Displaying maintenance intervals

- ☞ Tap on the **Maintenance intervals** button.
- ✓ All performed and pending maintenance work appears.



Fig. 237: Maintenance intervals: Selecting pending descaling

Carrying out descaling

- ☞ Tap on the **Descaling** button.
- ✓ The descaling program screen opens.

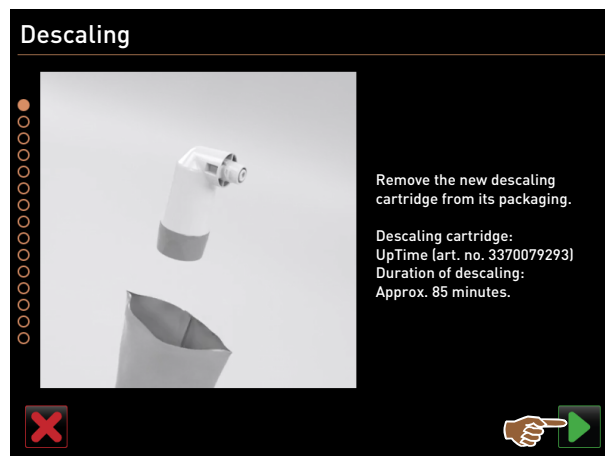

Fig. 238: Unpacking descaling cartridge

- ☞ Remove the Schaefer **Uptime!** descaling cartridge from the packaging.
- ☞ Tap on the ▶ button for the next step.
 - ✓ The instruction for checking the waste water outlet appears.
- ☞ Check if the waste water outlet in the drip tray is clear.
 - The ? button on the display leads to the step-by-step description for a waste water outlet test.
- ☞ Tap on the ▶ button for the next step.
 - ✓ The **Remove grounds container** instruction is displayed.

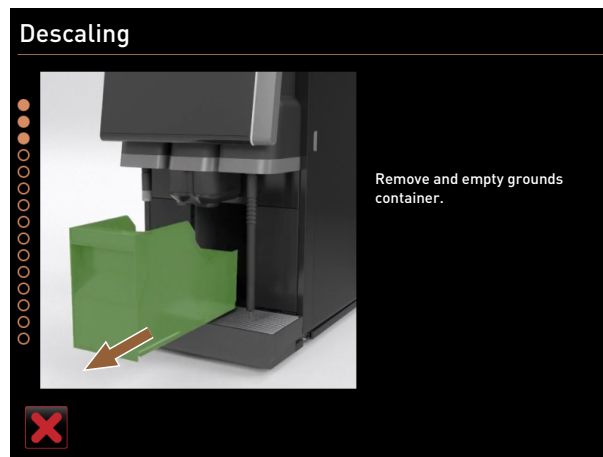

Fig. 239: Removing grounds container

- ☞ Pull the grounds container out of the machine.
- ☞ Empty and clean the grounds container.
- ✓ The **Insert descaling cartridge** instruction is displayed.



Fig. 240: Insert descaling cartridge

- ☞ Follow the steps shown in the animation:
- ☞ Open the cover on the front left.
- ☞ Remove the green sealing cap by turning it to the left.
- ☞ Fit the freshly unpacked decalcification cartridge and turn the descaling cartridge to the right.
- ✓ The descaling cartridge is inserted.
- ✓ The **Insert grounds container** instruction is displayed.

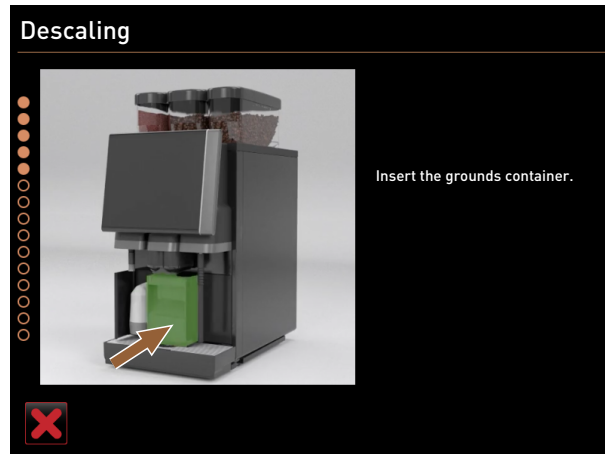

Fig. 241: Insert grounds container screen

- ☞ Push the cleaned grounds container into the machine.
- ✓ The **Remove milk container** (optional) instruction appears.



Fig. 242: Removing milk container



- ☞ Remove the milk container from the cooling unit.
- ☞ If necessary, empty and clean the milk container.
- CAUTION! Health problems due to uncooled milk! Store the milk container with milk in a cool place during descaling.**
- ☞ Tap on the  button for the next step.
- ✓ The **Place cleaning container in cooling unit** instruction is displayed.



Fig. 243: Inserting cleaning container

- ☞ Place the empty cleaning container in the cooling unit.

- ☞ Insert the milk hose into the cover of the cleaning container.
- ☞ Close the door of the cooling unit.
- ☞ Tap on the  button for the next step.
 - ✓ The **Position beverage outlet and steam wand** (optional) instruction appears.

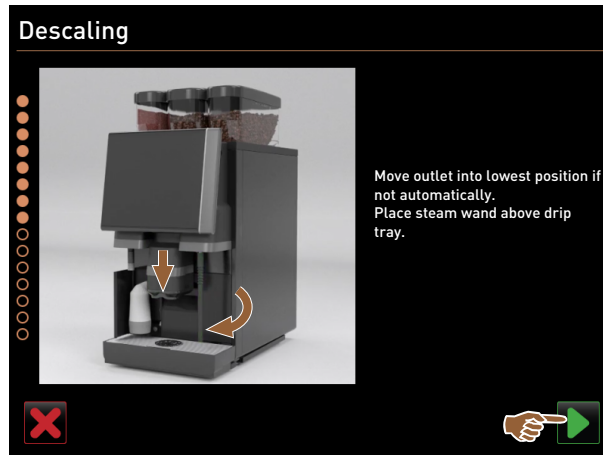

Fig. 244: Positioning beverage outlet and steam wand



- ☞ Move the manual beverage outlet to the lowest position.
- ☞ Point the steam wand (optional) downward vertically into the drip tray.
- ☞ Tap on the  button for the next step.
 - ✓ The **Read safety notes in the operating instructions** instruction appears.
- ☞ Start the descaling process with the  button.
- ✓ The descaling progress is shown in % and takes about 85 min.



Fig. 245: Starting descaling

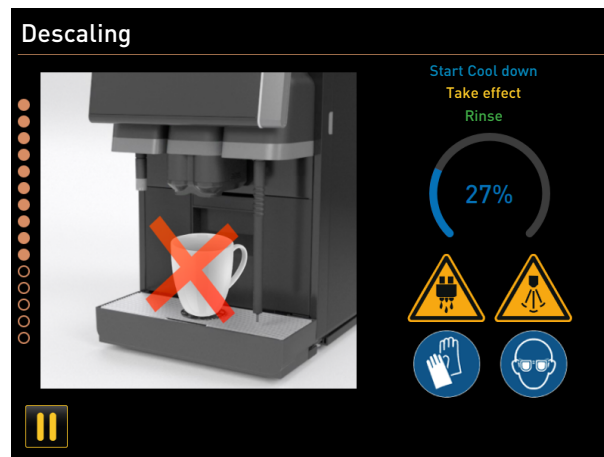

Fig. 246: Progress display for descaling

Progress display status:

- Blue progress display: Machine cooling starts.
- Yellow progress display: Descaling is active.
- Green progress display: Rinsing is active.

You can pause the descaling process with the  button and continue it with the  button.

Completing descaling process

The descaling process is complete when the instruction for removing the descaling cartridge appears.

- ☰ Wait for the instruction on the display before removing the descaling cartridge.



Fig. 247: Removing descaling cartridge

- ☞ Remove the descaling cartridge from the machine.
 - ✓ The **Reattach protective cap** instruction appears.
- ☞ Replace the green protective cap.
- ☞ Close the cover on the front left.
- ☞ Tap on the  button for the next step.
 - ✓ The **Remove cleaning container** instruction is displayed.



Fig. 248: Removing and emptying cleaning container



- ☞ Pull the milk hose out of the cover of the cleaning container.
- ☞ For cooling units with Twin Milk: Pull out both milk hoses.
- ☞ Remove the cleaning container from the cooling unit.
- ☞ Empty the cleaning container.
- ☞ Tap on the  button for the next step.
 - ✓ The **Insert milk container** instruction is displayed.



Fig. 249: Inserting milk container

- ☞ Place the milk container with chilled milk in the cooling unit.
- ☞ Tap on the  button for the next step.
 - ✓ The **Reorder descaling cartridge** instruction is displayed.
 - ✓ The article number is displayed in the user interface.
- ☞ Order a cartridge from your service partner for the next descaling process.
- ☞ Tap on the  button for the next step.
 - ✓ The descaling program closes.
 - ✓ The machine is restarted.
 - ✓ Ready for use status and the user interface are displayed.
 - ✓ The last descaling carried out is displayed in the Service menu under **Maintenance intervals**.

See also

- 📖 [Checking waste water drainage \[▶ 179\]](#)
- 📖 [Descaling \[▶ 178\]](#)

12.6 Disposing of descaling cartridge

The descaling cartridge is made of plastic and is completely emptied and rinsed with water after descaling.

- After proper descaling, the descaling cartridge must be disposed of as plastic waste or together with household waste.
- If descaling has been interrupted, the descaling cartridge must be disposed of as hazardous waste in accordance with local regulations.

12.7 Descaling with ProCare

The ProCare cleaning process takes approx. 85 min. The machine is not ready for use during this time.

The ProCare descaling process must be fully and correctly completed. Repeating the ProCare descaling process is mandatory if descaling is incomplete or was completed incorrectly.

The machine is not ready for use until the descaling process has been completed correctly.

Scheduled descaling

The scheduled descaling process is pre-programmed by the service technician in the presence of the machine operator. The scheduled descaling starts automatically.

Additional descaling

The additional descaling process can be called up and carried out by the machine operator at any time.

- ☰ The red cleaning pouch has been correctly inserted and put into operation.
- ☞ Tap on the **Service menu** button.
 - ✓ The **Service menu** opens.
- ☞ Tap on the **Maintenance intervals** button.
 - ✓ All performed and pending maintenance work appears.
- ☞ Tap on the **Descaling** button.
 - ✓ The descaling program screen opens.
 - ✓ The instruction for checking the waste water outlet appears.
- ☞ Check if the waste water outlet in the drip tray is clear.
 - The **?** button on the display leads to the step-by-step description for a waste water outlet test.
- ☞ Tap on the **▶** button for the next step.
 - ✓ The **Remove grounds container** instruction is displayed.





Fig. 250: Removing grounds container

- ☞ Pull the grounds container out of the machine.
- ☞ Empty and clean the grounds container.
 - ✓ The **Insert grounds container** instruction is displayed.
- ☞ Push the cleaned grounds container into the machine.
 - ✓ The instruction prompting you to connect the milk hoses to the ProCare Plug & Clean connection appears.



Fig. 251: Connecting milk hoses to Plug & Clean

- ☞ Connect the milk hoses to the ProCare Plug & Clean connections.
 - ✓ The instruction to pull down the beverage outlet (if not automatic) and position the steam wand is displayed.
- ☞ Pull down the beverage outlet if not automatic.
- ☞ Point the steam wand downward vertically into the drip tray.
- ☞ Tap on the  button for the next step.
 - ✓ The **Read safety notes in the operating instructions** instruction appears.
- ☞ Read and follow the safety notes.
- ☞ Start the descaling process with the  button.
- ✓ The descaling progress is shown in % and takes about 85 min.

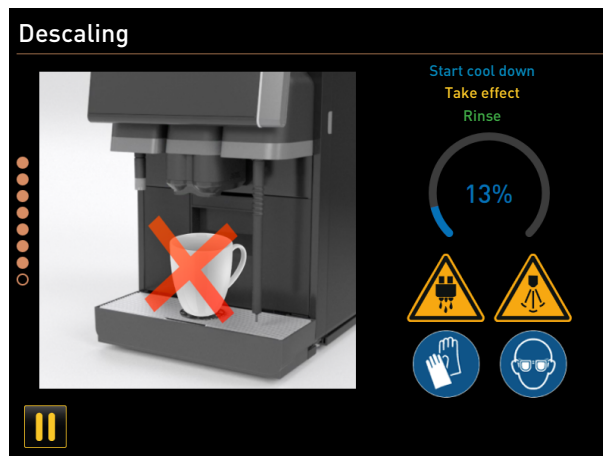

Fig. 252: Progress display for descaling

Progress display status:

- Blue progress display: Machine cooling starts.
- Yellow progress display: Descaling is active.
- Green progress display: Rinsing is active.

You can pause the descaling process with the  button and continue it with the  button.

Completing descaling process

- The instruction prompting you to remove the milk hoses from the ProCare Plug & Clean connection appears.

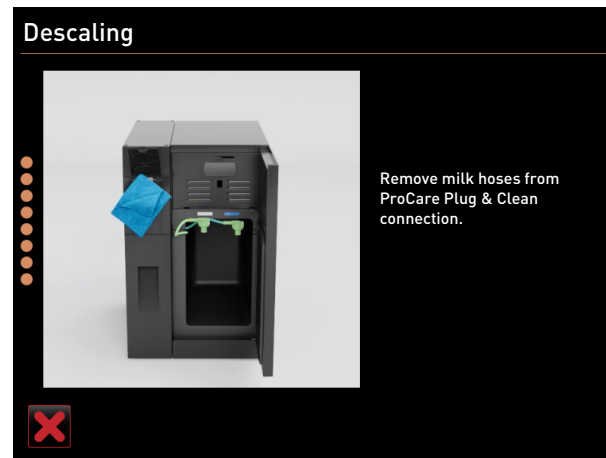

Fig. 253: Removing milk hoses from Plug & Clean

- ☞ Remove the milk hoses from the ProCare Plug & Clean connections.
- ☞ Clean the Plug & Clean connections with a clean, damp cloth.
- ✓ The descaling process is complete and the machine restarts.
- ✓ The boiler heats up.
- ✓ The ready for use status and the user interface are displayed.
- ✓ The last descaling carried out is displayed in the Service menu under Maintenance intervals.

See also

- Descaling [▶ 178]

13 Advanced settings

This chapter contains information about configuring the machine.



WARNING

Risk of injury due to insufficient qualification!

Improper handling can lead to considerable personal injury and property damage.

The following activities may only be carried out by service staff.

13.1 User interface elements

The following graphic elements are used for operation in the advanced settings:

Buttons



The **Restart** button restarts the machine.

A restart is required after the machine configurations have been changed.



The **Activate/Confirm** button confirms the selection, e.g. of an assigned coffee type or a temperature setting.



The **Cancel/Delete** button has the following functions:

- Reset counters
- Canceling beverage dispensing
- Close window/page



The **Confirm** button is used to confirm performed instructions for action.



The **Next** button opens a selection list or takes you to the next programme step.



The **Back** button takes you back to the previous window or the previous page.



The **Save** button saves the parameter settings made.



The **Copy** button copies an already configured beverage as a basis for additional beverage configurations.



The **Add** button adds beverages or beverage steps.

The beverages are taken from the list of available beverages. The additional beverage is automatically added to the list of configured beverages.



The **Beverage step configuration** button takes you to the settings for the beverage configuration with the individual beverage steps.



The **On/Off** switch activates or deactivates a function.

- Lit up green = On
- Matt gray = Off

Other operating elements

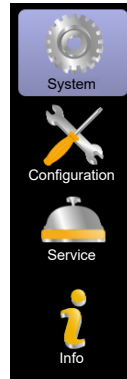

Fig. 254: Machine configuration settings menu

Machine configurations are divided into the following settings:

- System
- Configuration (software)
- Service
- Info

The parameters displayed depend on the authorizations of the selected profile. All settings and configuration options are listed in the **Service technician** profile.



Cup sizes

Fig. 255: Structure tree (statistics)

The **(+)** button expands the structure tree.

The **(-)** collapses the structure tree.



Fig. 256: Input field

A name for a beverage designation, beverage group, ingredient or for the menu cards can be entered in the **input field** using the keyboard that appears.

Tapping the input field opens the keyboard input.



Fig. 257: Virtual keyboard

The virtual keyboard can be used to enter alphanumeric character strings in an input field.

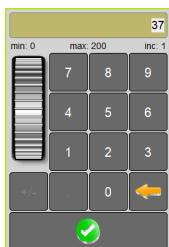

Fig. 258: Entering parameter values

The value of a parameter can be entered in the following ways:

- Setting with setting dial
- Input with keyboard

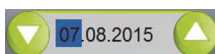

Fig. 259: Factory setting for date and time

The date and time values are set using the **down arrow** or **up arrow** buttons.

13.2 USB interface

In the machine, software updates, data storage or data exchange are performed using a USB stick. The USB port is located behind the operating unit.

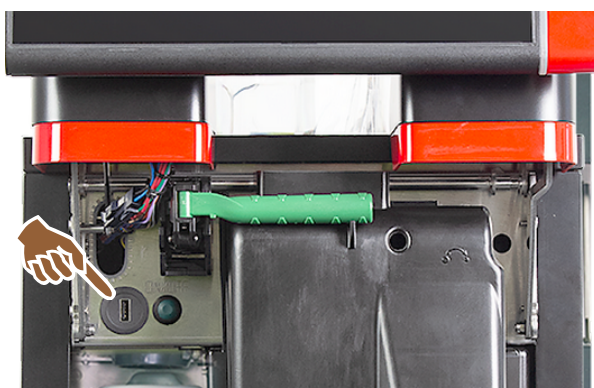

Fig. 260: Position of the USB interface

- 🔑 Unlock the user panel and slide it upwards until it automatically engages.
- ✓ The USB port is located to the left of the On/Off button.

See also



- 📖 Opening and closing the operating unit [▶ 70]

13.3 Profiles and authorizations

Profiles are used to manage different activities with the machine and the authorizations required for them.

13.3.1 Overview of profile authorizations

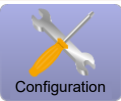
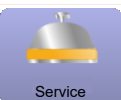
Only the profiles **Machine operator**, **Caretaker** and **Service technician** can manually start cleaning or descaling in the Service menu.

Settings	Parameter	Caretaker	Bookkeeper (reduced)	Head of service	Quality manager	Machine operator
	Grinder / Brewing unit					
	Grounds container capacity	x	-	-	-	-
	Grounds container emptying time	x	-	-	-	-
	Current grounds container counter	x	-	-	-	-
	Center, right grinder calibration value	x	-	-	-	-
	Milk system (milk level monitoring)	x	-	-	-	-
	Milk container					
	Milk 1 hose length from squeeze valve - cooling unit	x	-	-	-	-
	Milk 2 hose length from squeeze valve - cooling unit	x	-	-	-	-
	Milk monitoring configuration	x	-	-	-	-
Flavour Point (flavor level monitoring)	x	-	-	-	-	
	General (language)	x	x	x	x	x
	Time/Date/Timer (Monday to Sunday)	x	-	-	-	-
	Switch-on/off times	x	-	-	-	-
	Menu card (beverage field)	-	x	x	-	-
	Grinder service	x	-	-	-	-
	Import data	x	-	-	-	x
	Reset cleaning	x	-	-	-	-
	Back up database	x	-	-	-	-
	Media manager	x	-	-	-	x
	Show versions	x	x	x	x	x
	Machine counters	x	-	x	-	-
	Beverage statistics	x	x	x	-	-
	Cleaning statistics	x	-	x	x	-
	Maintenance statistics	x	-	-	-	-
	Beverage dispensing statistics	x	x	x	-	-
	Water hardness statistics	x	-	-	-	-
	Machine accounting statistics	x	x	x	-	-
	Beverage accounting statistics	x	x	-	-	-

13.3.2 Caretaker profile

The caretaker is the first point of contact in the event of technical faults. He or she possesses sound technical knowledge and works regularly with the machine.

Except for the service technician, the caretaker has access to the most service functions.

 Functions in the Service menu

In the **Caretaker** profile, the following functions are available for direct selection in the Service menu:

- Start rinsing
- Touch screen cleaning
- Switch quick info on/off
- Switch-off
- Cleaning
- Maintenance intervals
- Ingredient management

 Settings

The following settings can be changed in the **Caretaker** profile:

- System
- Configuration
- Service
- Info

13.3.3 Bookkeeper profile

The **Bookkeeper** and **Bookkeeper reduced** have limited service functions.

 Functions in the Service menu

In the **Bookkeeper** profile, the following functions are available for direct selection in the Service menu:

- Start rinsing
- Touch screen cleaning
- Switch quick info on/off
- Switch on Free vending mode if there is a payment system (bookkeeper)
- Switch-off
- Start maintenance (descaling)
- Ingredient management

 Settings

The following settings can be changed in the **Bookkeeper** profile:

- Configuration
- Info

13.3.4 Chef de service profile

The chef de service is a department or restaurant manager and his/her area of responsibility also includes administrative activities.

The facilities manager has access to some statistics of the machine to get an overview of the type and quantity of beverages served.

The chef de service has limited access to the service functions. He or she has more statistics at its disposal than the quality manager and the machine operator.

Functions in the Service menu

In the **Chef de service** profile, the following functions are available for direct selection in the Service menu:

- Start rinsing
- Touch screen cleaning
- Switch quick info on/off
- Switch-off
- Maintenance intervals
- Ingredient management

Settings

The following settings can be changed in the **Chef de service** profile:

- Configuration
- Info

13.3.5 Quality manager profile

The quality manager is responsible for the quality of the beverages from the machine. To ensure quality, it is particularly important to check the cleaning times.

The quality manager has limited access to the service functions. The quality manager has more statistics at its disposal than the machine operator.

Functions in the Service menu

In the **Quality manager** profile, the following functions are available for direct selection in the Service menu:

- Start rinsing
- Touch screen cleaning
- Switch quick info on/off
- Switch-off
- Maintenance intervals
- Ingredient management

Settings

The following settings can be changed in the **Quality manager** profile:

- Configuration
- Info

13.3.6 Machine Operator profile

The machine operator is the normal operator of the machine and therefore only a few service functions are available to him/her. He/She can set the language and view the machine version in order to pass on the information to a service technician if errors occur.

Functions in the Service menu

In the **Machine operator** profile, the following functions are available for direct selection in the Service menu:

- Start rinsing
- Touch screen cleaning
- Switch quick info on/off
- Switch-off
- Cleaning
- Maintenance intervals
- Ingredient management

Settings

The following settings can be changed in the **Machine operator** profile:

- Configuration
- Info

13.4 Configuring machine

The following chapter contains information on the configuration options for the machine:

- System configuration, e.g. grounds container capacity
- Software configuration, e.g. date and time
- Service settings, e.g. grinder service
- Information, e.g. beverage statistics

13.4.1 Configuring system

You can make the following settings on the System setting screen:

- **Grinder/Brewing unit** system setting
- **Milk system** system setting
- **Flavour Point** system setting (equipment variant)

☞ Tap on the **System**  button.

✓ The **System** setting screen opens.

Grinder/Brewing unit system setting

The grinder/brewing unit setting opens the following menu items for system settings and displays:

- Grounds container: Capacity
- Grounds container: time to empty [s]
- Grounds container: current counter
- Center grinder calibration value (10 s) [g]
- Right grinder calibration value (10 s) [g] (equipment variant)
- Left grinder calibration value (10 s) [g] (equipment variant)

Authorized profiles

- Service technician
- Caretaker

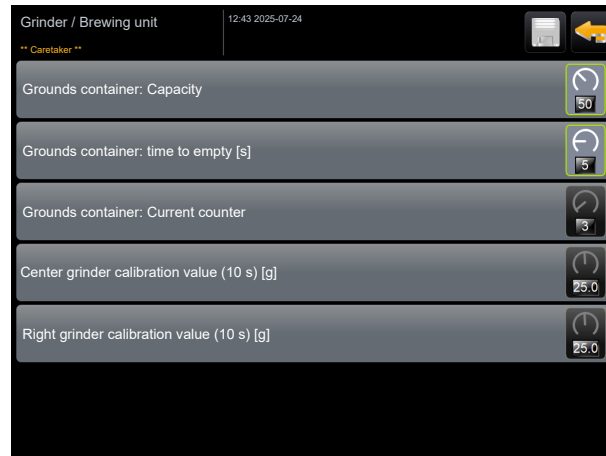

Fig. 261: Settings for the grinder/brewing unit

Configuring grounds container capacity

With this setting, the number of cycles (coffee cakes) until the Empty grounds container message appears is defined.

Setting range	Standard
0 – 150 coffee cakes	60 coffee cakes

- ☞ Default: Set the value to 60 coffee cakes. Do not exceed this value.
 - ✓ The coffee machine blocks the dispensing of coffee beverages after 65 brewing cycles (+ 5) until the grounds container has been emptied.
- ☞ With grounds disposal (equipment variant): Set the value to 0 coffee cakes.
 - ✓ The number of cycles (coffee cakes) is ignored.

Grounds container: Setting time for emptying [s]

This setting defines the period of time until the current grounds container counter is reset to 0 after emptying.

Setting range	Standard
0 – 30 s	5 s

- ☞ Set the value to 5 s.
- ☞ Empty the grounds container when the corresponding instruction is shown in the display. If the grounds container is only pulled out briefly and then pushed back in again immediately, the counter is retained and is not reset.
- ☞ Do not reinsert the emptied grounds container for at least 5 s.
- ✓ The **Current grounds container counter** is reset to 0.

Grounds container: current counter

The display provides information on the brewing cycles executed since the last time the grounds container was emptied. If the preset value for the capacity of the grounds container is reached, the instruction for emptying the grounds container appears.

This menu item is purely a display in the **Caretaker** profile. Settings are not possible.

Center grinder calibration value (10 s) [g]

The calibration value in grams is recorded with this setting for the center grinder during grinder calibration.

Service technicians can change the value.

Setting range	Standard
1.0 – 50.0 g	In line with the calibration performed

- ☞ Start calibration in the **Service – Grinder service** setting.
- ☞ Execute calibration using the assistant.
- ☞ Enter the calculated value in this input field (only in the **Service technician** profile).
- ✓ Grinder calibration for the center grinder is complete.
- ✓ The grind quantity output corresponds to the grind quantity set in the coffee recipe.

The calibration value in grams displayed in this parameter can be changed by service technicians for general adjustment of the coffee beverages from the center grinder without having performed grinder calibration.

Adjusting the calibration value affects all coffee recipes that have been assigned to the center grinder.

Right grinder calibration value (10 s) [g] (equipment variant)

The process is the same as for the center grinder.

Left grinder calibration value (10 s) [g] (equipment variant)

The process is the same as for the center grinder.

Milk system setting

The Milk system setting opens the following menu items for system settings and displays:

- Milk container
- Milk 1 hose length squeeze valve -> cooling cell [cm]
- Milk 2 hose length squeeze valve -> cooling cell [cm]
- Milk level detection

Authorized profiles

- Service technician
- Caretaker

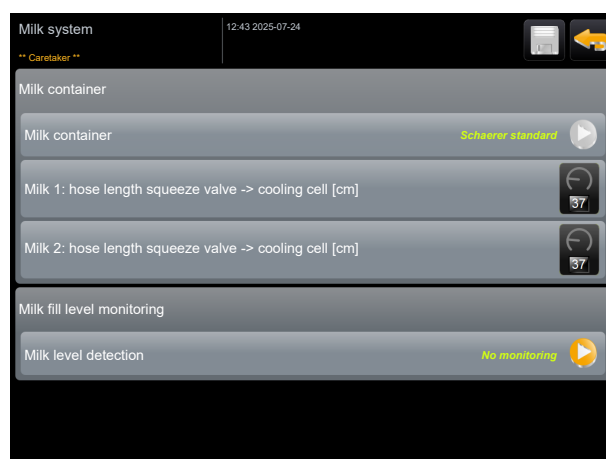

Fig. 262: Settings for the milk system

Milk container

This setting is used to record the milk hose length up to the milk container. The setting refers to the effective milk hose length with or without riser pipe in the milk container.

Service technicians can change the value.

Setting range	Standard
Custom or Schaerer standard (only to be set by service technicians)	Schaerer standard

Custom

- ☞ Select the **Custom** option (only in the **Service technician** profile).
 - ✓ The milk hose length is not recorded automatically.
- ☞ Measure the exact milk hose length from the milk container to the squeeze valve in the machine and record the value calculated for **Milk 1 hose length from squeeze valve -> cooling cell [cm]**.

Schaerer standard

- ☞ Select the **Schaerer standard** option (only in the **Service technician** profile).
 - ✓ The milk hose length is automatically detected.
 - ✓ The standard setting of *37 cm* in the following parameter does not require any additional adaptation.

See below the description for the **Milk 1 hose length from squeeze valve -> cooling cell [cm]** parameter.

Milk 1 hose length squeeze valve -> cooling cell [cm]

This setting is used to record the milk hose dimension from the squeeze valve to the cooling cell for the external milk hose.

Service technicians can change the value.

Setting range	Standard
0 – 200 cm (only to be set by service technicians)	37 cm (with the Schaerer standard option)

If the **Custom** option is selected in the previous **Milk container** parameter, the exact milk hose length can be entered in the **Service technician** profile.

For service technicians

- ☞ Measure the milk hose length from squeeze valve in the machine up to the milk container in the cooling device.
- ☞ Record the calculated value for the **Milk 1 hose length from squeeze valve -> cooling cell [cm]** parameter.
 - ✓ The system now knows the milk hose length.
 - ✓ The correct milk quantity is periodically exchanged for the **rinsing interval of external milk hose**.

With the standard equipment, the **Schaerer standard** option is selected in the **Milk container** parameter. This setting corresponds to the correct milk hose length of *37 cm*.

The following milk systems require the Custom option:

- Cooling unit left of the coffee machine
- Cooling unit with Twin Milk
- Under-counter cooling unit
- Under-machine cooling unit
- All optional accessories, e.g. Cup & Cool and Centre Milk

Milk 2 hose length squeeze valve -> cooling cell [cm]

This setting is used to record the milk hose dimension from the squeeze valve to the cooling cell for the second milk hose for the **Twin Milk**.

Service technicians can change the value.

Setting range	Standard
0 – 200 cm (only to be set by service technicians)	37 cm (with the Schaerer standard option)

The process corresponds to that for the **Milk 1 hose length from squeeze valve -> cooling cell [cm]**.

Milk level detection

This setting defines the fill level monitor behavior for the milk container.

Setting range	Standard
No monitoring	No monitoring
Warning	
Disable beverage dispensing	

No monitoring option

Milk monitoring is configured, but is not used.

Warning option

If a low milk level is detected, a message appears on the display. The dispensing of additional milk beverages is possible.

Disable beverage dispensing option

If a low milk level is detected, a message appears on the display. The dispensing of milk beverages is blocked.

Activate milk system

These settings determine how the milk system is activated.

Setting range	Standard
Activate milk system after cleaning:	Ask
<ul style="list-style-type: none"> ▪ Ask ▪ Activate automatically 	
Activate milk system at machine start:	No action
<ul style="list-style-type: none"> ▪ No action ▪ Ask if deactivated ▪ Activate automatically 	
Fill up milk system at first milk beverage (only for machines with BestFoam):	Not activated
<ul style="list-style-type: none"> ▪ Not activated ▪ Enabled 	

Flavour Point system setting (equipment variant)

The Flavour Point setting opens the following **Syrup level monitoring** menu item.

Syrup level monitoring

Authorized profiles

- Service technician
- Caretaker

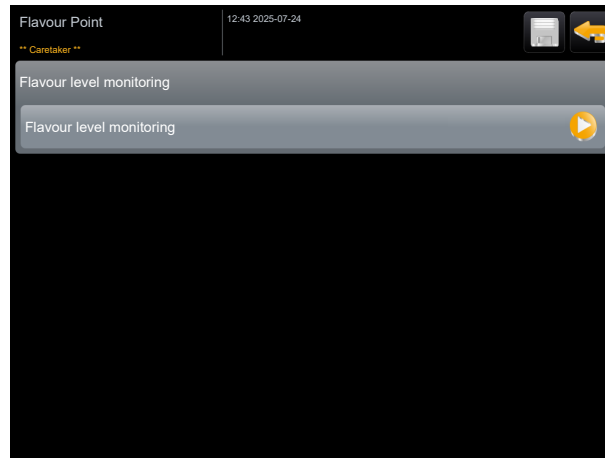

Fig. 263: Settings for Flavour Point

Flavour point fill level monitoring

This setting defines the fill level monitor behavior for Flavour Point syrup bottles.

Setting range	Standard
No monitoring	No monitoring
Warning	
Disable beverage dispensing	

No monitoring option

Syrup monitoring is configured, but is not used.

Warning option

If a low fill level is detected in the syrup bottle, a message appears on the display. Other beverages containing aromas can be dispensed.

Disable beverage dispensing option

If the fill level in the syrup bottle is low, a message appears on the display. The dispensing of flavored beverages is blocked.

13.4.2 Configuring software

Calling up software settings

In the configuration settings on the left, tap on the **Configuration** category.

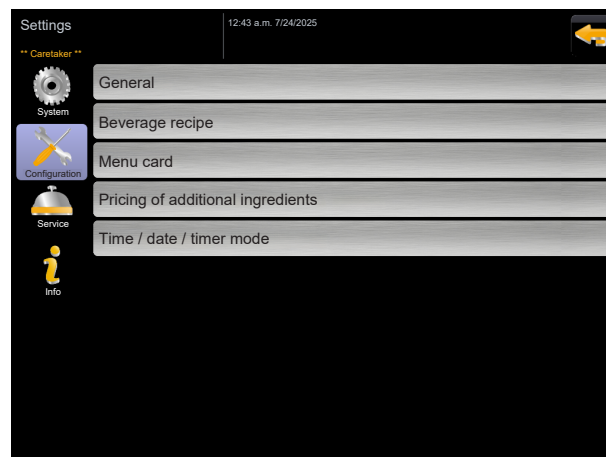

Fig. 264: Configuring software

To select the desired setting:

- **General:** Configuring language
- **Time/Date/Timer mode:** Display date, time and time zone, configure switch-on/off time

Configuring language

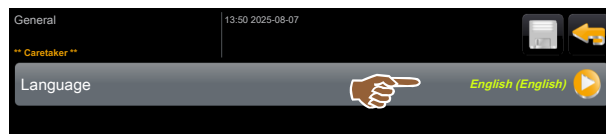

Fig. 265: Configuring language

- ☞ Tap on the button next to the set language.
 - ✓ The menu for the language selection appears.
- ☞ Select the desired language.
- ☞ Save the setting and load the new settings into the machine with .
- ☞ Go back with and restart the machine with .
- ✓ All display messages and parameter designations appear in the activated language.

Displaying date, time and time zone

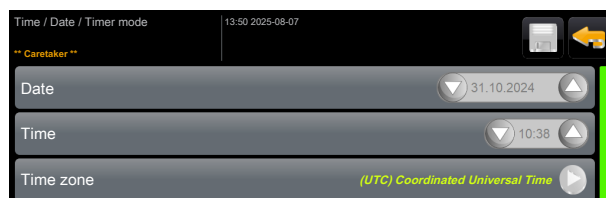

Fig. 266: Displaying date, time and time zone

This menu displays information on the date, time and time zone. The settings could not be configured.

The time zone is selected by the service technician during the commissioning program. When the time zone is set, the time and date are automatically adopted from the selected zone.

Configuring switch-on/switch-off time

- ☞ In the **Time / Date / Timer mode** menu, select the **Schedule for timer mode** button.
- ☞ Activate the switch-on/switch-off time for the desired day of the week using the button.
 - ✓ The dialog for adding a switch-on time or switch-off time appears.

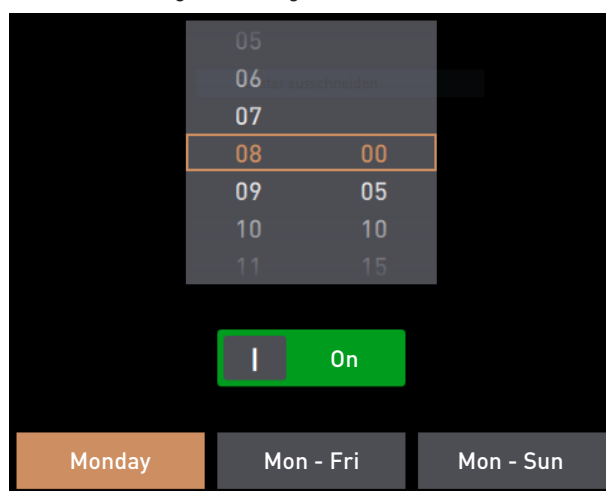

Fig. 267: Dialog for adding a switch-on time or switch-off time

- ☞ Set the time.

- ☞ Activate the switch-on time by sliding the I button to the left (On, green) or the switch-off time by sliding the I button to the right (Off, red).
- ☞ Select the weekdays for which the switch-on time or switch-off time should be activated by activating the corresponding button (e.g. Mon – Fri).

The system automatically displays the corresponding time format (24 h or 12 h a.m./p.m.) depending on the selected time zone.

Adjusting beverage prices

Setting of beverage price with or without payment system





- ☞ Select the **Configuration – Menu card** setting.
 - ✓ The main beverage selection is displayed.
- ☞ Variant: Use the arrows to navigate to the right to additional beverages.
- ☞ Select the  button to the right of the desired beverage group.
 - ✓ The **menu group** is displayed and the beverages in the menu group are listed.
- ☞ Select the  button to the right of the beverage for which you want to set a beverage price.
 - ✓ The **Menu card item** screen for the desired beverage is displayed with all the cup sizes configured for the beverage.
- ☞ Select the  button next to the desired cup size.
 - ✓ The **Edit menu card item** screen appears.
- ☞ Select the price button you want to set.
- ☞ Set the price by turning the setting dial.



Fig. 268: Beverage price button with setting dial

- ☞ Save the price with the  button.
- ☞ When all prices have been set, save the settings with the  button.
- ☞ Repeat the steps for all beverages that require a price adjustment.
- ✓ The beverage prices are set.

See also

- 📄 Saving changes and loading them into the machine [▶ 220]

13.4.3 Configuring service settings

You can make the following settings on the Service setting screen:

- **Grinder service** setting
- **Back up database** service setting
- **Reset descaling counter** service setting
- **Reset descaling** service setting
- **Reset cleaning** service setting

- ☞ Tap on the **Service**  button.
- ✓ The **Service** setting screen opens.

13.4.3.1 Grinder service with manual grinding level adjustment



WARNING

Risk of injury due to insufficient qualification!

Improper handling can lead to considerable personal injury and property damage.
The following activities may only be carried out by service staff.

The Grinder service setting starts the following display-guided service functions on the grinder after confirmation:

- Changing grinding disks
- Adjusting grinding level
- Calibrate grinder

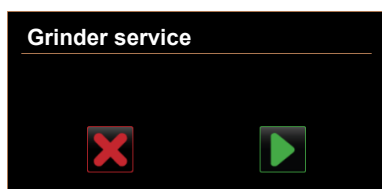

Fig. 269: Starting grinder service

- ☞ The machine is equipped with manual grinding level adjustment.
- ☞ Tap on the **Service** → **Grinder service** setting.
 - ✓ The confirmation dialog opens.
- ☞ Confirm with .
 - ✓ The service functions for the grinder are available.
- ☞ Open the tab for the desired grinder (left, right, center).



Fig. 270: Grinder service screen

Changing grinding disks



DANGER

Risk of electrocution!



Danger to life due to improper handling of electrical appliances.

- ☞ Always disconnect the power supply before carrying out maintenance work.



WARNING

Risk of crushing and cutting injuries from rotating grinding discs!



There is danger of crushing and cutting injuries due to rotating grinding discs in the grinder.

- ☞ Never reach into the bean hopper when the machine is switched on.
- ☞ Switch off the machine and disconnect the power plug before performing any work on the grinder.

The following steps are required to replace the grinding disks:

- ☞ Switch off the machine and disconnect it from the power supply.
- ☞ Remove the manual grinding level adjustment and install new grinding disks.
- ☞ Close the empty grinder by hand until there is noticeable resistance (disk on disk).
- ☞ Open the grinder 45° counterclockwise.
- ☞ Reassemble the manual grinding level adjustment.
- ☞ Switch the machine back on and navigate to the **Grinder service** screen.
- ☞ Tap on the **Confirm change of grinding disks** button.
- ☞ Confirm the installation steps on the **Confirm change of grinding disks** screen with the  button.
- ✓ The preparation steps for adjusting the grinding level are displayed.

Adjusting grinding level

- ☞ Continue the setting steps after **Changing grinding disks** or tap on the **Adjust grinding level** button directly in the grinder service.
- ☞ The preparation steps for adjusting the grinding level are displayed. Empty and clean the grounds container and reinsert it.
- ☞ Confirm that the grounds container is inserted with the  button.
- ☞ Set the grinding level manually.

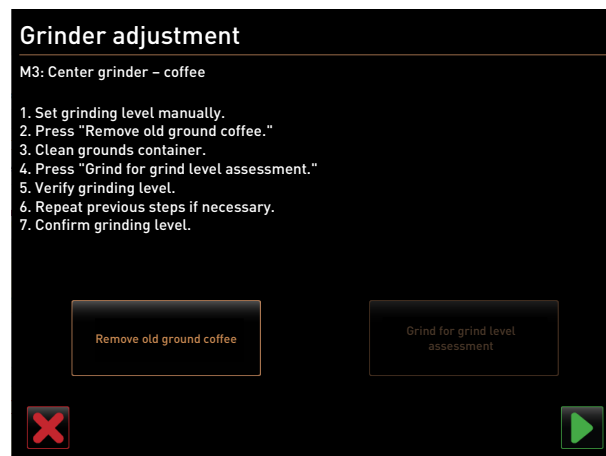

Fig. 271: Grinding level adjustment: Removing old ground coffee

- ☞ Tap on the **Remove old ground coffee** button.
- ✓ The old ground coffee is removed.

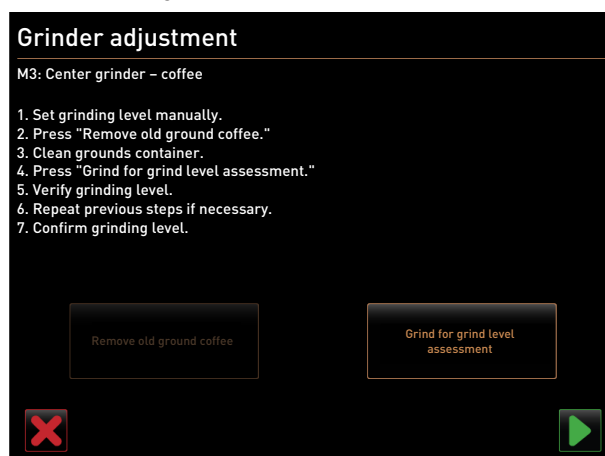



Fig. 272: Adjust grinding level: grind for grind level assessment

- ✓ The **Grind for grind level assessment** button becomes active.
- ☞ Clean the grounds container again.
- ☞ Tap on the **Grind for grind level assessment** button.
- ✓ A grind is performed.
- ☞ Check the grinding level and repeat the steps for grinding level adjustment if necessary or confirm the set grinding level with the  button.
- ✓ Preparation for calibrating the grinder appears.

Calibrate grinder

Calibration is required in the following cases:

- ▣ The machine is new.
- ▣ The operating time has been more than a year.
- ▣ The grinding level is changed.
- ▣ The grinder is opened.
- ▣ The grinding disks are changed.
- ▣ The type of coffee has been changed.
- ☞ Continue the settings steps after **grinding level adjustment** or tap directly on the **Grinder calibration** button in the grinder service.
 - ✓ The preparation steps for calibration are displayed.
- ☞ Empty and clean the grounds container and reinsert it.
- ☞ Confirm that the grounds container is inserted with the  button.
 - ✓ Reference grinding starts.

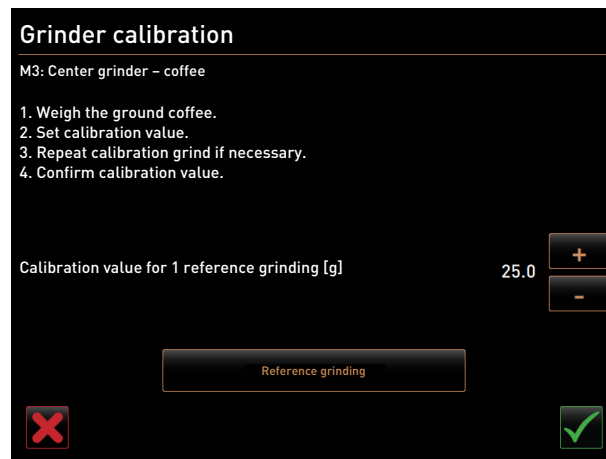



Fig. 273: Calibrate grinder

- ☞ Weigh the ground coffee of the reference grind.
- ☞ Set the calibration value (determined weight of ground coffee) using the **Plus** or **Minus** button.
- ☞ If needed, start additional reference grinding with the **Reference grinding** button.
- ☞ If several reference grinding operations are performed, always weigh the entire resulting quantity of ground coffee and enter the amount as a reference value.
 - ✓ The machine automatically detects all triggered grinds and calculates the correct grind quantity itself.
- ☞ Confirm calibration of the grinder with the  button.
- ✓ The **Grinder service** screen opens.
- ✓ The set grinder is ready for use.

13.4.3.2 Grinder service with electric grinding level adjustment



WARNING

Risk of injury due to insufficient qualification!

Improper handling can lead to considerable personal injury and property damage.

The following activities may only be carried out by service staff.

The **Grinder service** setting starts the following display-guided service functions on the grinder after confirmation:

- Changing grinding disks
- Adjusting grinding level
- Grinder initialization
- Calibrate grinder

The grinder service for electric grinding level adjustment also requires grinder initialization as well as grinder adjustment via the grind level motors.

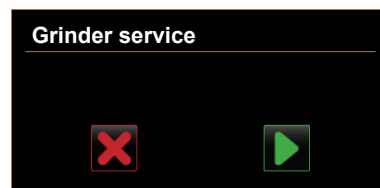

Fig. 274: Starting grinder service

- ☞ The machine is equipped with electric grinding level adjustment.
- ☞ Tap on the **Service** → **Grinder service** setting.

- ✓ The confirmation dialog opens.
- ☞ Confirm with .
- ✓ The service functions for the grinder are available.
- ☞ Open the tab for the desired grinder (left, right, center).



Fig. 275: Grinder service screen

Changing grinding disks



DANGER

Risk of electrocution!



Danger to life due to improper handling of electrical appliances.

- ☞ Always disconnect the power supply before carrying out maintenance work.



WARNING

Risk of crushing and cutting injuries from rotating grinding discs!



There is danger of crushing and cutting injuries due to rotating grinding discs in the grinder.

- ☞ Never reach into the bean hopper when the machine is switched on.
- ☞ Switch off the machine and disconnect the power plug before performing any work on the grinder.

The following steps are required to replace the grinding disks:

- ☞ Switch off the machine and disconnect it from the power supply.
- ☞ Remove the grinder level motor and install new grinding disks.
- ☞ Close the empty grinder by hand until there is noticeable resistance (disk on disk).
- ☞ Open the grinder 45° counterclockwise.
- ☞ Reassemble the grinding level motor.
- ☞ Switch the machine back on and navigate to the Grinder service screen.
- ☞ Tap on the Confirm change of grinding disks button.
- ☞ Confirm the installation steps on the Confirm change of grinding disks screen with the  button.
- ✓ The preparation steps for adjusting the grinding level are displayed.

Adjusting grinding level

- ☞ Continue the setting steps after Changing grinding disks or tap on the Adjust grinding level button directly in the grinder service.
 - ✓ The preparation steps for adjusting the grinding level are displayed.
- ☞ Empty and clean the grounds container and reinsert it.
- ☞ Confirm that the grounds container is inserted with the  button.

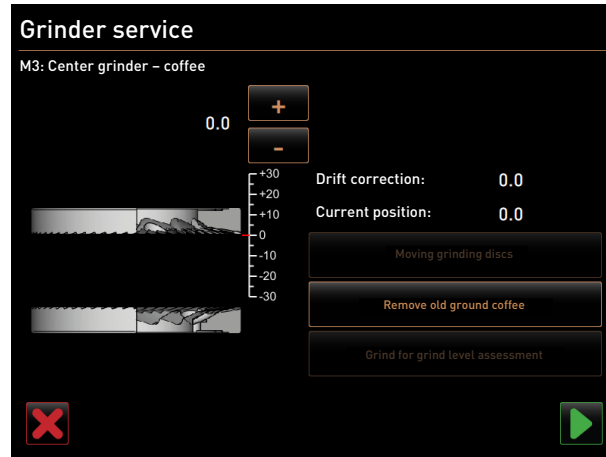

Fig. 276: Grinding level adjustment: Removing old ground coffee

- ☞ Tap on the Remove old ground coffee button.
 - ✓ The old ground coffee is removed.
 - ✓ The Grind for grind level assessment button becomes active.

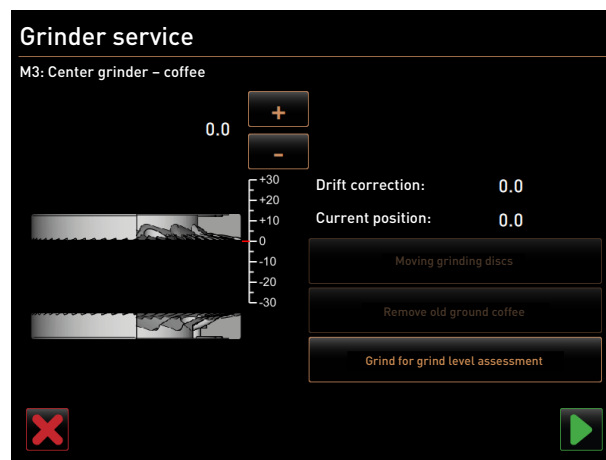

Fig. 277: Adjust grinding level: grind for grind level assessment

- ☞ Clean the grounds container again.
- ☞ Tap on the Grind for grind level assessment button.
 - ✓ A grind is performed.



Fig. 278: Adjust grinding level: move grinding discs

- ☞ Adjust the grinding level result with the Plus = coarser or Minus = finer button.
- ☞ Make grinding level adjustments in small ± 1 steps.
- ☞ Use the Move grinding disks button to set the grinding disk to the previously set position.
- ☞ Check the grinding level and repeat the steps for grinding level adjustment if necessary or confirm the set grinding level with the button.
- ✓ Preparation for calibrating the grinder appears.

Calibrate grinder

Calibration is required in the following cases:

- The machine is new.
- The operating time has been more than a year.
- The grinding level is changed.
- The grinder is opened.
- The grinding disks are changed.
- The type of coffee has been changed.

Calibrate grinder

Calibration is required in the following cases:

- ☞ The machine is new.
- ☞ The operating time has been more than a year.
- ☞ The grinding level is changed.
- ☞ The grinder is opened.
- ☞ The grinding disks are changed.
- ☞ The type of coffee has been changed.
- ☞ Continue the settings steps after **grinding level adjustment** or tap directly on the **Grinder calibration** button in the grinder service.
 - ✓ The preparation steps for calibration are displayed.
- ☞ Empty and clean the grounds container and reinsert it.
- ☞ Confirm that the grounds container is inserted with the button.
 - ✓ Reference grinding starts.

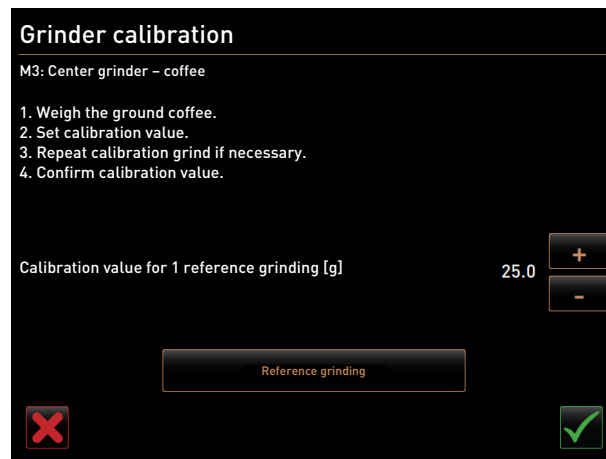

Fig. 279: Calibrate grinder

- ☞ Weigh the ground coffee of the reference grind.
- ☞ Set the calibration value (determined weight of ground coffee) using the **Plus** or **Minus** button.
- ☞ If needed, start additional reference grinding with the **Reference grinding** button.
- ☞ If several reference grinding operations are performed, always weigh the entire resulting quantity of ground coffee and enter the amount as a reference value.
 - ✓ The machine automatically detects all triggered grinds and calculates the correct grind quantity itself.
- ☞ Confirm calibration of the grinder with the button.
- ✓ The **Grinder service** screen opens.
- ✓ The set grinder is ready for use.

Grinder initialization

The grinder must be initialized in the following cases:

- After a malfunction
- After the grinding disks have been replaced, electric grind level adjustment must be initialized.

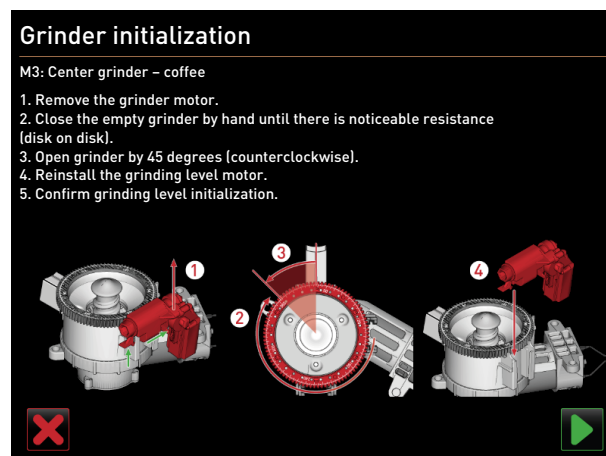

Fig. 280: Grinder initialization

- ☞ Follow the displayed instructions.
- ☞ Remove the grinder level motor and install new grinding disks.
- ☞ Close the empty grinder by hand until there is noticeable resistance (disk on disk).
- ☞ Open the grinder 45° counterclockwise.
- ☞ Reassemble the grinding level motor.
- ☞ Confirm the grinder initialization installation steps with the button.

13.4.3.3 Backing up database



NOTE

Property damage due to data loss!

The touch screen contains an SD memory card for storing the machine data.

- ☞ Back up the database on a USB data carrier before carrying out an update.
- ☞ Back up the database on a USB data carrier before replacing the touch screen.
- ☞ Insert the previously used SD memory card into the new touch screen. This ensures it is ready for use immediately.



Fig. 281: Position of the USB interface

- ☞ Lift the user panel.
- ☞ Insert the USB data carrier into the USB interface.
- ☞ Tap on the **Service -> Back up database** setting.
 - ✓ The machine database is saved to the USB stick.
 - ✓ The saved database version is compatible with the installed machine software version.
- ☞ Remove the USB data carrier when the **Data backup complete** message appears on the display.
- ☞ Close the user panel.

The database is saved on the USB data carrier under `Schaerer/SCA3/backup/database/sca3db.db3_<yyyymmdd_hhmmss>`.

The database is automatically saved periodically every 5 minutes to the SD memory card inserted in the touch screen. It is also saved directly in the system at the same time.

With a **downgrade**, the database version saved on the USB data carrier is again compatible with the older machine software.

NOTICE! The manufacturer generally does not recommend software downgrades. These should only be performed in the event of serious problems or safety-related issues, if recommended by a technical information notice.

The following data is stored on the USB data carrier:

- Machine number
- Beverage recipes
- Hardware configuration
- All counter levels

13.4.3.4 Reset descaling counters



NOTE

Property damage due to skipped descaling processes!

Failure to perform descaling can lead to damage and faults.

- ☞ Carry out descaling operations which are not performed automatically because the counter has been reset as soon as possible and start them manually.

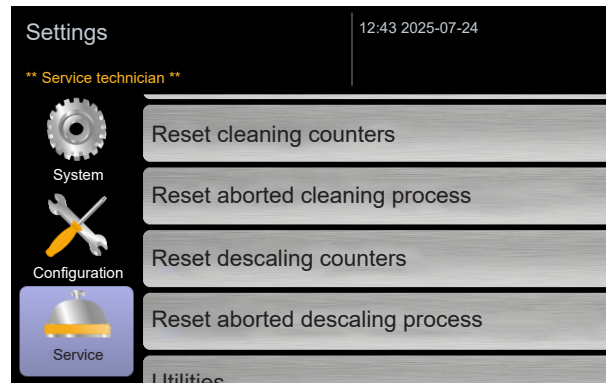

Fig. 282: Buttons for resetting

The parameter deactivates a pending descaling process.

- ☞ Tap on the **Service -> Reset descaling counter** setting.
- ☞ Confirm that the process with the button.
- ✓ The descaling counter is reset and any pending descaling process is deleted.
- ✓ The next automatic descaling process takes place according to the configuration in the **System - Maintenance** setting.

13.4.3.5 Reset descaling/cleaning

A cleaning or descaling program can be interrupted using the button. A power failure also leads to interruption of any cleaning or descaling operation that is in progress.

After a canceled cleaning or descaling process, the status of the machine remains in **Cleaning** or **Descaling** mode. In order to leave the mode, it is necessary to reset the cleaning or descaling flag.

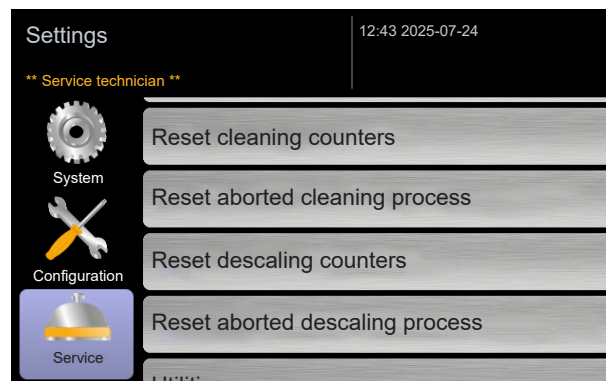

Fig. 283: Buttons for resetting

- ☞ Tap on the **Service -> Reset aborted descaling/cleaning process** setting.
- ☞ Confirm that the process with the button.
 - ✓ The cleaning flag an descaling flag is reset.
 - ✓ An interrupted cleaning or descaling process is reset.
 - ✓ Any pending descaling operation is deleted.

- ✓ The next automatic cleaning or descaling process will only take place according to the configuration in the **System – Cleaning** and **System – Maintenance** settings.

☞ It is absolutely essential to restart cleaning or descaling right away.

13.4.4 Calling up information



Fig. 284: Button for Info menu

The **Info** button opens a menu containing various information.



This information must be passed on to a service technician when reporting an error.

Setting > Info – Show versions

- Authorized profiles:
- Caretaker
 - Head of service, Quality manager
 - Machine operator
 - Bookkeeper
 - Bookkeeper reduced

Function:	Shows information about the installed versions of the machine software.
Setting range:	No setting possible
Standard:	–

Name	Version
Touch panel software	SOUL_5.48.1.cc77217_Sim (Created: 2024-12-10 21:49)
Power section software	0.0
Database version	2124
BSP version	N/A
MAC address	28:00:AF:B7:B2:11
Qt version	5.6.3
SQLite version	3.8.10.2
Software SCA3	Copyright 2017 Schaerer Ltd., Switzerland. All rights reserved.
Show license information	Show license information
Export license information	Export license information to USB

Fig. 285: Versions

The following information can be read off:

- Touch panel software version
- Power unit software version
- Database version
- BSP accounting system version
- Mac address version
- Qt version (source code)
- Qt license version
- SQLite version
- Copyright software SCS

Setting > Info – Machine counter

Authorized profiles:	<ul style="list-style-type: none"> ▪ Caretaker ▪ Head of service
Function:	Shows an overview of beverage counters according to the ingredient they contain.
Setting range:	No setting possible
Standard:	–

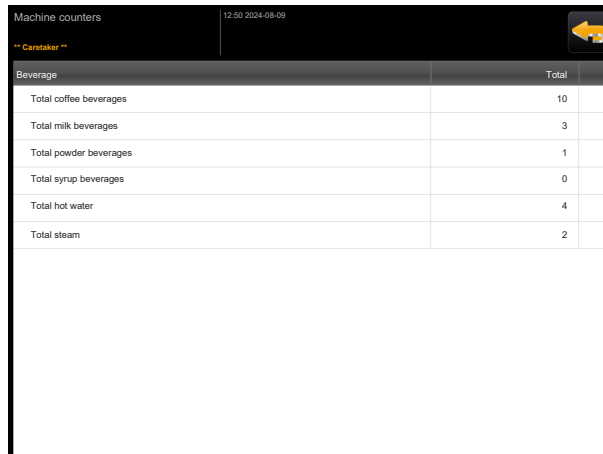

The screenshot shows a mobile application interface titled 'Machine counters' with a timestamp of 12:50 2024-08-09 and a user profile 'Caretaker'. Below the header is a table with two columns: 'Beverage' and 'Total'. The table contains the following data:

Beverage	Total
Total coffee beverages	10
Total milk beverages	3
Total powder beverages	1
Total syrup beverages	0
Total hot water	4
Total steam	2

Fig. 286: Machine counters

Example of ingredients with a chociatto beverage:

- 1. ingredient = coffee
- 2. ingredient = fresh milk or topping
- 3. ingredient = choco

The following information can be read off:

- Total coffee beverages
- Total milk beverages
- Total powder beverages
- Total hot water
- Total steam

All beverages added to the menu cards are listed.

Setting > Info – Beverage statistics

Authorized profiles:	<ul style="list-style-type: none"> ▪ Caretaker ▪ Head of service ▪ Bookkeeper ▪ Bookkeeper reduced
Function:	Shows information about the dispensed beverages.
Setting range:	Resetting the counter levels (individual or total)
Standard:	Custom

Beverage	Beverage count
- Espresso	4
Medium Single	4
+ Espresso	---
- Cappuccino	---
Medium Single	---
- Cappuccino	---
Small Single	---
Medium Single	---
Large Single	---
- Flat white	1
Medium Single	1
- Chocciato	---
Medium Single	---

Fig. 287: Beverage statistics

Resetting individual counters

- ☞ Tap on the **X** button for the corresponding beverage in the right column.
- ✓ The beverage counter for the selected beverage is set to zero.

Resetting all counters

- ☞ Tap on the large **X** button at the top of the screen.
- ✓ All listed beverage counters are reset to zero.

Setting > Info – Cleaning statistics	
Authorized profiles:	<ul style="list-style-type: none"> ▪ Caretaker ▪ Head of service ▪ Quality manager
Function:	Shows information about performed cleaning work.
Setting range:	No setting possible
Standard:	–

Date / Time	Profile	System	Event
2024-06-25 13:10	Machine operator	Plug&Clean system	Done
2024-06-24 09:40	Service technician	Coffee system	Done
2024-06-24 09:17	Service technician	Steam boiler rinsing	Reset aborted
2024-06-24 09:17	Service technician	Coffee system	Reset timestamps
2024-06-24 09:17	Service technician	Steam boiler rinsing	Reset timestamps
2024-06-24 09:17	Service technician	Plug&Clean system	Reset timestamps
2024-06-24 09:17	Service technician	powder system	Reset timestamps
2024-06-24 09:17	Service technician	Milk system	Reset timestamps
2024-06-21 17:43	Service technician	powder system	Reset aborted
2024-06-21 17:42	Service technician	Coffee system	Reset timestamps
2024-06-21 17:42	Service technician	Steam boiler rinsing	Reset timestamps
2024-06-21 17:42	Service technician	Milk system	Reset timestamps
2024-06-21 17:42	Service technician	powder system	Reset timestamps

Fig. 288: Cleaning statistics

The following information can be read off:

- Date and time
- Profile
- System

▪ Event

Performed, cancelled and reset cleaning operations are displayed in the **Event** column.

Setting > Info – Maintenance statistics

Authorized profiles:	Caretaker
Function:	Shows information about performed maintenance (descaling).
Setting range:	No setting possible
Standard:	–

Date / Time	Profile	Maintenance intervals	Event
2024-06-25 13:10	Service technician	Descaling	Reset counters
2024-06-24 09:40	Service technician	Coffee system	Reset counters
2024-06-24 09:17	Service technician	Steam boiler rinsing	Reset aborted
2024-06-21 17:43	Service technician	Coffee system	Reset aborted
2024-06-21 09:09	Service technician	Steam boiler rinsing	Reset counters
2024-06-21 07:57	Service technician	Plug&Clean system	Reset counters

Fig. 289: Maintenance statistics

The following information is listed:

- Date and time
- Profile
- System
- Event

Performed, cancelled and reset descaling processes are displayed in the **Event** column.

Setting > Info – Beverage dispensing statistics

Authorized profiles:	<ul style="list-style-type: none"> ▪ Caretaker ▪ Head of service ▪ Bookkeeper ▪ Bookkeeper reduced
Function:	Shows information on all beverage dispensed with the contained beverage data.
Setting range:	The button deletes all counter levels.
Standard:	–

Beverage	Date / Time
Espresso	2024-06-25 10:13:49
Cup size	Medium Single
Aborted	Yes
Duration	23.0 s
Extraction time	0.0 s
Beverage modified	No
Hot milk	2024-06-24 09:19:12
Beverage	2024-06-24 08:18:40
Cup size	Medium Single
Aborted	Yes
Duration	17.6 s
Extraction time	0.0 s
Beverage modified	No
Steam	2024-06-24 08:08:36

Fig. 290: Beverage dispensing statistics

The following information can be read for each type of beverage:

- Cup sizes
- Canceled dispensing processes
- Output time
- Extraction time
- Beverage modified

In the **Date/Time** column, the date on which the beverage was dispensed is entered, including the time. The values, such the cup size, for the various dispensed beverage options are also listed.

Setting > Info – Water hardness statistics

Authorized profiles:	Caretaker
Function:	Shows information about the water hardness settings made to date.
Setting range:	No setting possible
Standard:	–

Date / Time	Water hardness [°dKH]
2024-06-25 13:10	12
2024-06-24 09:40	9

Fig. 291: Water hardness statistics

The following information can be read off:

- Date and time
- Water hardness

Each adjustment to the water hardness is listed in a new entry.

Settings > Info – Machine accounting statistics

Authorized profiles:	▪ Caretaker
----------------------	-------------

Settings > Info – Machine accounting statistics	
	<ul style="list-style-type: none"> ▪ Bookkeeper ▪ Bookkeeper reduced
Function:	Provides information on the number of beverages dispensed with or without a sale and the total of these beverage prices.
Setting range:	Since last reset/Since initialisation
Standard:	–

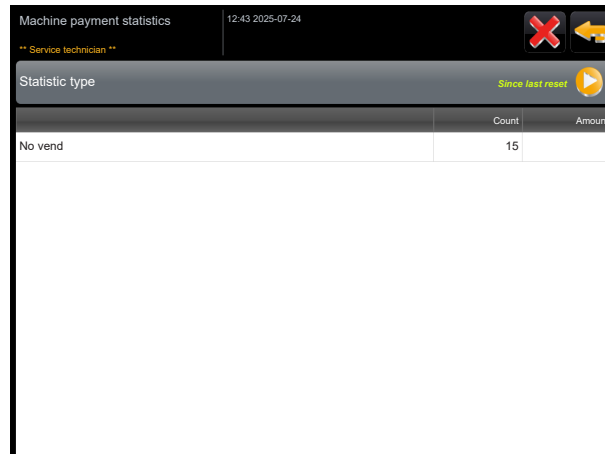





Fig. 292: Machine payment statistics

Since last reset

The **Since last reset** statistics can be deleted. This makes it possible to allow counters to run for a specific time.

- ☞ Open the dropdown list with the  button.
- ☞ Select the **Since last reset** statistic.
- ☞ Tap on .
- P An instruction for confirmation appears.
- ☞ Confirm with .
- ✓ The **Since last reset** statistic is deleted.

Since initialization

The statistics with the **Since initialisation** setting cannot be deleted. **Initialisation** means **since commissioning**.

Settings > Info – Beverage accounting statistics	
Authorized profiles:	<ul style="list-style-type: none"> ▪ Caretaker ▪ Bookkeeper ▪ Bookkeeper reduced
Function:	Provides information about all dispensed beverages, their configuration, the number of beverages and their price. Depending on the default setting, the user statistics show the entries Since the last reset or as complete statistics Since initialisation (commissioning).
Setting range:	Since last reset/Since initialisation
Standard:	–

Statistic type	Vend type
+ Cappuccino	1
+ Espresso	2
+ Steam	4
+ Flat white	1
+ Hot milk	1
+ Ristretto	1
+ Coffee	1

Fig. 293: Beverage accounting statistics

The following sales types are available:

- All
- No sale (all beverage without payment are listed.)

Since last reset

The **Since last reset** statistics can be deleted. This makes it possible to allow counters to run for a specific time.

- ☞ Open the dropdown list with the button.
- ☞ Select the desired statistic and the sales type.
- ☞ Select the **Since last reset** statistic.
 - ✓ The selected statistic with sales type appears.
- ☞ Tap on .
 - ✓ An instruction for confirmation appears.
- ☞ Confirm with .
- ✓ The **Since last reset** statistic is deleted.

Since initialization

The statistics with the **Since initialisation** setting cannot be deleted. **Initialisation** means **since commissioning**.

13.4.5 Saving changes and loading them into the machine

To save and load changes to the settings:

- ☞ Save the selection with .
- ☞ Exit the parameter and the setting with .
- ☞ Load the changes to the setting/parameter into the machine with .
- ✓ The machine restarts.

14 Troubleshooting

This chapter contains information about remedying problems and faults in the machine.

14.1 Type of fault display

A distinction can be made between the following error messages:

- Display via the functional lighting
- Messages in the display

14.2 Meaning of the functional lighting

The machine is equipped with functional lighting as standard. In addition to messages on the display, error messages are indicated by illuminated LED color strips on the machine.

The different colors have the following meanings:

- **White:** The machine is ready for use.
- **Orange:** Action is required soon (e.g. refilling, cleaning).
- **Red:** Machine error (e.g. grinder blocked, water flow error)

14.3 Notifications on the display

The following messages on the display can be distinguished:

- Simple error message
- Specific error message
- Error message in the Service menu

Simple error message

- ▣ **Simple error message** is activated in the user interface for **Display notification mode**.
- ▣ In the event of an error message, the machine remains out of operation until the service staff acknowledges the message.
- ▣ The **Inform service staff** instruction is displayed.
- ▣ The error message cannot be acknowledged.
- ☞ Inform the service staffs.

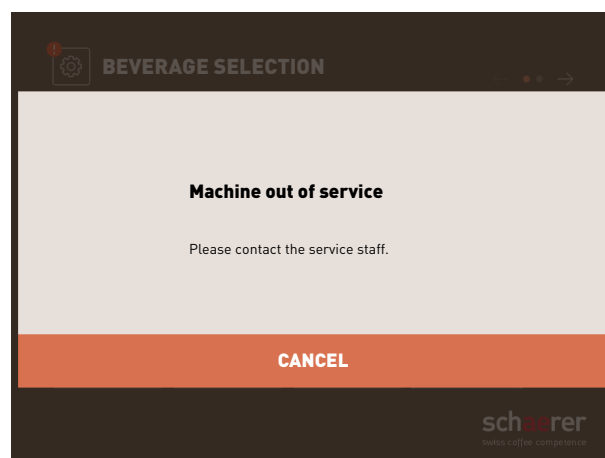

Fig. 294: Simple error message

Specific error message

- **Specific error message** is activated in the user interface for **Display notification mode**.
- In the event of an error message, the machine is briefly out of operation.
- **Restart** or **Inform service technician** instruction appears.
- Error messages can be partially acknowledged.
- ☞ Depending on error type: Befolgen Sie die Handlungsaufforderung und quittieren Sie die Fehlermeldung oder tippen Sie **OK** für einen Neustart.
 - ✓ The pending error is acknowledged or the machine restarts.
 - ✓ The machine is ready for use again.
- ☞ If the error message cannot be acknowledged, inform the service technician.

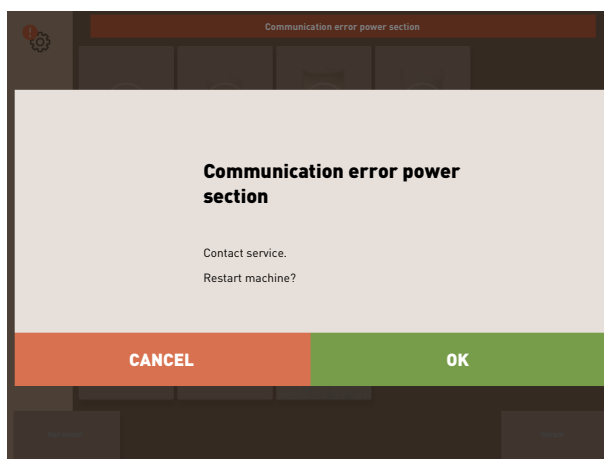

Fig. 295: Screen with error message



Fig. 296: Area with error message

Error message in the Service menu

In addition to the error messages in the user interface, the error messages are displayed in the Service menu.

Service menu button

The **Service menu** is opened with the Service menu button.



Fig. 297: Service menu button with messages

In the user interface, the **Service menu** button provides information about pending information or error messages:

- **Without color code:** No messages are pending in the Service menu.
- **Orange:** Information is pending in the Service menu.
- **Red:** Error messages or instructions for action are pending in the Service menu.

Calling up error message in the Service menu

- ☞ Tap on the **Service menu** button.
 - ✓ The Service menu opens and all pending error messages are listed.
- ☞ Open the error message with the  button.

- ☞ Carry out the displayed instruction for action and acknowledge any errors with **OK**.
- ☞ If the error message cannot be acknowledged, inform the service technician.

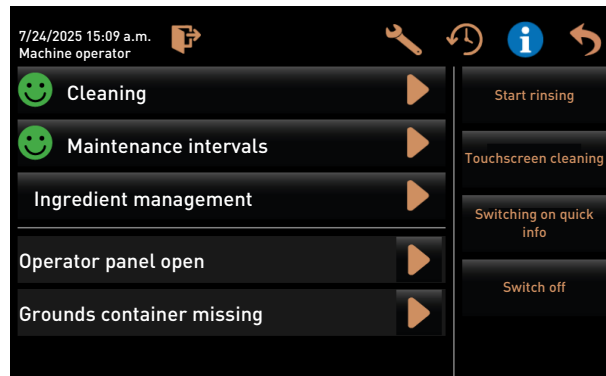

Fig. 298: Service menu with error message

14.4 Faults with display messages

In the case of faults with a display message, a distinction is made between the following categories:

- Fault
- Error
- Instruction
- Note

14.4.1 “Fault” display message

■ The following display messages are highlighted in red in the control system.



⚠ WARNING

Risk of infection from contamination!



Contamination and milk residues in the milk container can lead to infections. Infections can trigger health problems.

- ☞ Clean the milk container and cover before each filling.
- ☞ Wear protective gloves while cleaning.



⚠ CAUTION

Risk of crushing due to moving components!

The beverage outlet and operating unit can be moved manually. The grinder and the brewing unit move during operation. There is a risk of crushing when handling moving components.

- ☞ Only touch the beverage outlet using the provided handles.
- ☞ Always push the operating unit up or down with both hands.
- ☞ Never reach into the bean hopper or the opening of the brewing unit when the machine is switched on.

Display message	Cause	Remedy
Milk empty	The milk level in the milk container is empty or too low.	<ul style="list-style-type: none"> ☞ Fill the milk container immediately. ☞ Remove the container for fresh milk. ☞ Clean the container thoroughly.

Display message	Cause	Remedy
Flavour Point (syrup system) 1 – 4 empty	The syrup level in bottles 1 – 4 is empty or too low.	<ul style="list-style-type: none"> ☞ Fill the container with fresh pre-cooled milk ± 5 °C (41 °F) and put it back into the machine. ☞ Start the Flavour 1 – 4 process in the Service menu. ☞ Carry out the steps shown on the display. ☞ Remove and clean the hose. ☞ Reconnect the hose and activate the syrup pump with the Start pump button.
Grounds container full	The grounds container contains approx. 60 – 70 coffee cakes.	<ul style="list-style-type: none"> ☞ Empty the grounds container. ☞ Rinse out the grounds container and wipe it dry. ☞ Reinsert the grounds container.
Inserting grounds container	<p>The grounds container is missing.</p> <p>The grounds container has not been fully inserted into the machine.</p>	<ul style="list-style-type: none"> ☞ Correctly reinsert the grounds container into the cooling unit. ☞ Correctly reinsert the grounds container into the cooling unit.
Fill external drinking water tank (equipment variant)	The fill level of the external drinking water tank (equipment variant) is too low.	<ul style="list-style-type: none"> ☞ Remove the fill level sensor from the drinking water tank. ☞ Rinse out the drinking water tank with clean water and fill it. ☞ Reinsert the fill level sensor.
Empty waste water tank (equipment variant)	The fill level of the external waste water tank has been reached.	<ul style="list-style-type: none"> ☞ Remove the fill level sensor from the waste water tank. ☞ Empty the waste water tank. ☞ Rinse out the waste water tank. ☞ Reinsert the fill level sensor.
Center grinder (standard), right grinder (equipment variant) overloaded or blocked	An excessively high current value (>8 A) was measured over a defined period of time. The machine tries to restart grinding five times, then the Left or right grinder overloaded message appears. If a beverage is requested again in this state and the problems persist, the message changes to Grinder centre or right / blocked . Beverage dispensing is blocked.	<ul style="list-style-type: none"> ☞ Switch the machine off. ☞ Check the grinder for blockages and remove any foreign objects. ☞ Restart the machine. ☞ If the error is displayed again, the malfunction persists: Contact the service partner.
Fill with beans (center grinder empty)	The center bean hopper is empty.	☞ Refill beans.
Fill with beans (right grinder empty)	The right bean hopper is empty.	☞ Refill beans.
Fill ground coffee in manual inlet	No ground coffee was poured into the manual inlet.	<ul style="list-style-type: none"> ☞ Open the cover of the manual inlet in the centre bean hopper. ☞ Refill ground coffee. ☞ Close the cover of the manual inlet.
Fill choco or milk powder into 1. container (1. powder container empty)	The first powder container is empty.	☞ Fill the first powder container.
Fill choco or milk powder into 2. container (2. powder container empty)	The second powder container is empty.	☞ Fill the second powder container.
Tea hot water boiler or coffee overtemperature	<p>The water supply is interrupted.</p> <p>The machine has overheated.</p>	<ul style="list-style-type: none"> ☞ Check the level of the external/internal drinking water tank (equipment variant) and the condition of the mains water supply. ☞ Disconnect machine from the mains and let it cool off.

Display message	Cause	Remedy
	The SSR is defective. The excess temperature switch has triggered.	☞ Contact your service partner if the malfunction persists.
Steam boiler excess temperature	The water supply is interrupted. The steam system is clogged. The machine has overheated. The SSR is defective. The excess temperature switch has triggered.	☞ Check the level of the external/internal drinking water tank (equipment variant) and the condition of the mains water supply. ☞ Check and clean the beverage outlet and the steam system. ☞ Disconnect machine from the mains and let it cool off. ☞ Contact your service partner.
Hot water temperature too low, steam boiler temperature too low	The heating phase is still running. There is an error when heating up.	☞ Wait until the machine has heated up. ☞ Disconnect the machine from the power supply. ☞ Reconnect and switch on.
HW boiler heating time-out, steam boiler heating time-out	Although the heater is switched on, the set temperature was not reached within 5 min.	☞ Contact your service partner if the malfunction persists.
Hot water boiler NTC short-circuited, steam boiler NTC short-circuited	The main board does not detect any resistance. A maximum temperature (approx. 150 °C or 302 °F) is measured. Beverage dispensing is blocked.	☞ Contact your service partner if the malfunction persists.
Hot water boiler NTC interrupted, steam boiler NTC interrupted	The temperature sensor is interrupted. A minimum temperature sensor is measured.	☞ Contact your service partner if the malfunction persists.
Brewing unit overcurrent	Overcurrent was detected on the motor of the brewing unit.	☞ Contact your service partner if the malfunction persists.
Brewing unit closed current	Even when the brewing unit is not in operation, it must consume a minimal amount of current. If this is not the case, there is a fault. This may be caused by the brewing unit, the power board or the wiring.	☞ Check the brewing unit for blockages. ☞ Contact your service partner if the malfunction persists.
Inserting decalcification cartridge	The descaling product required for the descaling process is missing.	☞ Insert the decalcification cartridge. ☞ Remove the cartridge after descaling and when an instruction appears on the display.
Brewing unit time-out	The brewing unit does not have a home position switch. The position of the brewing cylinder is detected by measuring the current value. The following peak values are detected: upper and lower position. The following time-out is defined: If no current peak is detected within 10 s of the brewing unit being moved, Brewing unit time-out is displayed.	☞ Contact your service partner if the malfunction persists.
Water flow error	During dispensing of a coffee product, the flow meter performs less than the defined number of minimum revolutions. A blockage or partial blockage somewhere in the entire water system is likely.	☞ Check the level of the drinking water tank and the condition of the mains water supply. ☞ Check the internal or external drinking water tank. (Saturation of the filter reduces the water flow.)

Display message	Cause	Remedy
		<ul style="list-style-type: none"> ☞ Check whether the upper plunger is blocked or partially congested. ☞ Check the grinding level. If the grinder setting is too fine, this can inhibit or completely block the water flow. Check the grinding level. ☞ Contact your service partner if the malfunction persists.
Steam supply error	The level sensor detects a low level in the steam boiler. An attempt is made to fill the boiler. However, no water was detected by the level probe within 60 s. The filling process is canceled. The dispensing of beverages that require steam is blocked.	<ul style="list-style-type: none"> ☞ Contact your service partner if the malfunction persists.
Modbus processing error BP	Communication error between power unit and touch screen	<ul style="list-style-type: none"> ☞ Contact your service partner if the malfunction persists.
Modbus processing error MR	Communication error between cooling unit and touch screen	<ul style="list-style-type: none"> ☞ Check the wiring of the cooling unit and machine. ☞ Contact your service partner if the malfunction persists.
Payment system error	Communication error between payment system and touch screen	<ul style="list-style-type: none"> ☞ Restart the machine. ☞ Contact your service partner if the malfunction persists.
Machine out of service	Setting in Self-service mode if no beverages can be dispensed for various reasons.	<ul style="list-style-type: none"> ☞ Set the Configuration – Timer operation parameter setting accordingly. ☞ Check products such as coffee beans, milk, choco powder or milk powder. ☞ Check the temperature sensor in the cooling unit. ☞ Carry out the pending cleaning or descaling process. ☞ Contact your service partner if the malfunction persists.
Communication errors (various)	Communication error between software and various modules, such as the HCU power section, Flavour Point, brewing unit, manometer, etc.	<ul style="list-style-type: none"> ☞ Restart the machine. ☞ Contact your service partner if the malfunction persists.

14.4.2 “Error” display message

■ The following display messages are stored in yellow in the control system.

**WARNING****Risk of infection due to bacteria!**

Improper care and cleaning can make the dispensing of beverages hazardous in terms of food hygiene.

- ☞ Wear protective gloves while cleaning.
- ☞ Wash your hand thoroughly before and after cleaning.
- ☞ Clean the machine daily.
- ☞ For machines with milk system: Clean the milk container before each refill and after the end of dispensing.
- ☞ When cleaning the milk system with cleaning powder: Never add cleaning products to the milk container; always use the blue cleaning container.
- ☞ Never add cleaning products to the drinking water tank (internal/external).
- ☞ Never mix cleaning products.
- ☞ Store cleaning products separately from coffee, milk and automatic coffee machine powder (if available).
- ☞ Do not use abrasive cleaners, brushes or metal cleaning instruments.
- ☞ Do not touch any parts that come into contact with beverages after cleaning.
- ☞ Observe the dosing and safety notes on the cleaning product and follow them.

**CAUTION****Risk of crushing due to moving components!**

The beverage outlet and operating unit can be moved manually. The grinder and the brewing unit move during operation. There is a risk of crushing when handling moving components.

- ☞ Only touch the beverage outlet using the provided handles.
- ☞ Always push the operating unit up or down with both hands.
- ☞ Never reach into the bean hopper or the opening of the brewing unit when the machine is switched on.

Display message	Cause	Remedy
Brewing unit encoder error	The brewing unit motor encoder was not detected during machine initialization.	<ul style="list-style-type: none"> ☞ Restart the machine. ☞ Contact your service partner if the error persists.
Error in electric grinding level adjustment for center, left or right	The motor of the electric grinding level adjustment is running incorrectly.	<ul style="list-style-type: none"> ☞ Cancel the grinding level adjustment. ☞ Restart the machine. ☞ Contact your service partner if the error persists.
Machine configuration error	There is a discrepancy between the software and machine hardware.	<ul style="list-style-type: none"> ☞ Restart the hardware detection. ☞ Restart the machine. ☞ Contact your service partner if the error persists.
Steam wand temperature sensor interruption	The steam wand temperature sensor is not closed.	<ul style="list-style-type: none"> ☞ Restart the machine. ☞ Contact your service partner if the error persists.
Steam wand temperature sensor short circuit	The steam wand temperature sensor is defective.	<ul style="list-style-type: none"> ☞ Restart the machine. ☞ Contact your service partner if the error persists.
Reset descaling/cleaning	Cleaning/Descaling was interrupted/not fully completed.	<ul style="list-style-type: none"> ☞ Carry out cleaning/descaling in the Service menu.

Display message	Cause	Remedy
		☞ Acknowledge cleaning/descaling in the Service menu.
Milk level low	The fill level in the milk container is too low.	☞ Remove the milk container. ☞ Clean the milk container thoroughly. ☞ Fill the milk container with fresh pre-cooled milk (3 – 5 °C or 37.4 – 41 °F) and put it back into the machine.
Grounds container full soon	The grounds container will soon contain approx. 60 – 70 coffee cakes.	☞ Empty the grounds container when convenient.
Close user panel	The user panel is open or has not been fully closed.	☞ Press the user panel down until it clicks into place.
External drinking water tank soon empty (equipment variant)	The fill level of the external drinking water tank (equipment variant) is too low.	☞ Empty the drinking water when convenient.

14.4.3 “Instruction” display message

The following display messages are stored in white in the control system.



⚠ CAUTION

Risk of crushing due to moving components!

The beverage outlet and operating unit can be moved manually. The grinder and the brewing unit move during operation. There is a risk of crushing when handling moving components.

- ☞ Only touch the beverage outlet using the provided handles.
- ☞ Always push the operating unit up or down with both hands.
- ☞ Never reach into the bean hopper or the opening of the brewing unit when the machine is switched on.

Display message	Cause	Remedy
Insert grounds container	The grounds container is missing or has not been fully inserted into the machine.	☞ Correctly insert the grounds container into the machine.
Close user panel	The user panel is open or has not been fully closed.	☞ Press the user panel down until it clicks into place.
Fill external drinking water tank (equipment variant)	The fill level of the external drinking water tank is too low.	☞ Remove the fill level monitor from the external drinking water tank. ☞ Rinse out the external drinking water tank with clean water and fill it. ☞ Reinsert the fill level monitor.
Empty waste water tank (equipment variant)	The fill level of the external waste water tank has been reached.	☞ Remove the fill level monitor from the external waste water tank. ☞ Rinse out the external waste water tank with clean water and fill it. ☞ Reinsert the fill level monitor.
Fill with beans (center grinder empty)	The center bean hopper is empty.	☞ Fill the bean hopper.
Fill with beans (right grinder empty)	The right bean hopper is empty.	☞ Fill the bean hopper.
Fill ground coffee in manual inlet	No ground coffee was poured into the manual inlet.	☞ Open the manual inlet in the center bean hopper. ☞ Fill with ground coffee. ☞ Close the manual inlet.

Display message	Cause	Remedy
Fill choco or milk powder into 1st container (1st powder container empty)	The 1st powder container is empty.	☞ Refill the first powder container.
Insert decalcification cartridge	The descaling process requires the descaling product from the decalcification cartridge.	☞ Insert the decalcification cartridge. ☞ Remove the decalcification cartridge after descaling and when an instruction appears on the display.

14.4.4 “Note” display message

■ The following display messages are stored in blue in the control system.

Display message	Cause	Remedy
Caution: A blocked waste water outlet can cause flooding.	There are coffee ground residues in the waste water.	☞ Check the waste water outlet and the drip tray for blockages and clean them.
Wait until the payment system is fully initialized.	Initialization is in progress.	☞ Wait until initialization of the payment system is complete.
Wait until telemetry connection is established or contact service.	The Coffee Link display is pending.	☞ Restart the telemetry system. ☞ If the fault persists, contact your service partner.

14.5 Malfunctions without display messages



DANGER

Danger to life due to defective or non-original connection cable!

If the connection cable is defective or not original, there is a risk of electrocution and fire.

- ☞ Only use original connection cables. The country-specific original connection cable is available from the service partner.
- ☞ Connection cables that can be plugged in at both ends can be replaced by the customer.
- ☞ Have permanently connected connection cables replaced by a service technician.



WARNING



Risk of infection due to bacteria!

Improper care and cleaning can make the dispensing of beverages hazardous in terms of food hygiene.

- Wear protective gloves while cleaning.
- Wash your hand thoroughly before and after cleaning.
- Clean the machine daily.
- For machines with milk system: Clean the milk container before each refill and after the end of dispensing.
- When cleaning the milk system with cleaning powder: Never add cleaning products to the milk container; always use the blue cleaning container.
- Never add cleaning products to the drinking water tank (internal/external).
- Never mix cleaning products.
- Store cleaning products separately from coffee, milk and automatic coffee machine powder (if available).
- Do not use abrasive cleaners, brushes or metal cleaning instruments.
- Do not touch any parts that come into contact with beverages after cleaning.
- Observe the dosing and safety notes on the cleaning product and follow them.

Fault	Cause	Remedy
The display is dark.	The machine is not connected to the power supply.	<ul style="list-style-type: none"> Connect the machine to the power supply. If the fault persists, contact your service partner.
	The machine is not switched on.	<ul style="list-style-type: none"> Switch the machine on. If the fault persists, contact your service partner.
There are no beverages with milk available.	The milk container is empty.	<ul style="list-style-type: none"> Refill the milk container. If the fault persists, contact your service partner.
	The milk system is clogged.	<ul style="list-style-type: none"> Clean daily. If the fault persists, contact your service partner.
	The milk system is incorrectly deactivated.	<ul style="list-style-type: none"> Check the cable connection from the machine control cable to the cooling unit. Activate the milk system. If the fault persists, contact your service partner.
There are no beverages with milk foam available.	The milk container is empty.	<ul style="list-style-type: none"> Refill the milk container. If the fault persists, contact your service partner.
	The milk system is clogged.	<ul style="list-style-type: none"> Clean daily. If the fault persists, contact your service partner.
	The milk system is incorrectly deactivated.	<ul style="list-style-type: none"> Check the cable connection from the machine control cable to the cooling unit. Activate the milk system.

Fault	Cause	Remedy
There are no beverages with syrup (Flavour Point) available.	The syrup bottle is empty.	<ul style="list-style-type: none"> ☞ Clean daily. ☞ If the fault persists, contact your service partner.
	The Flavour Point system is clogged.	<ul style="list-style-type: none"> ☞ Fill the syrup bottle. ☞ If the fault persists, contact your service partner.
	The Flavour Point system is incorrectly deactivated.	<ul style="list-style-type: none"> ☞ Clean daily. ☞ If the fault persists, contact your service partner. <ul style="list-style-type: none"> ☞ Check the cable connection from the machine control cable to the Flavour Point. ☞ Clean daily. ☞ If the fault persists, contact your service partner.

15 Disassembly



WARNING

Risk of injury due to insufficient qualification!

Improper handling can lead to considerable personal injury and property damage.



The following activities may only be carried out by specialist staff.



WARNING

Health problems caused by heavy machine!

The weight of the machine exceeds the permissible load that a single person is allowed to lift or carry alone. The load of the machine may cause health problems when lifted or carried by a single person.



-  Do not lift or carry the machine alone.
-  Only lift or carry the machine with two people.



CAUTION



Risk of injury due to machine tipping over!

Improper lifting of the machine can cause it to tip. A tipping or falling machine can cause injury.

-  Do not lift the machine alone.
-  Only lift the machine with two people.

After the period of use

After the machine has reached the end of its service life

-  Empty the machine.
-  Disassemble the machine.
-  Dispose of the machine in an environmentally-friendly manner.

16 Disposal

The device is subject to the Regulation on Electrical and Electronic Waste WEEE 2012/19/EU and must not be disposed of with household waste.

We ensure and guarantee compliance with the traceability requirements set out in Regulation (EC) No. 1935/2004 as well as manufacture according to good manufacturing practice as set out in Regulation (EC) No. 2023/2006.



The machine must be disposed of properly in accordance with local and legal regulations.

☞ Contact your service partner for this purpose.

If no return or disposal agreement has been made, disassembled components must be recycled.

- ☞ Scrap the metal.
- ☞ Recycle the plastic elements.
- ☞ Dispose of the remaining components sorted according to material properties.
- ☞ Dispose of operating materials and cleaning products in line with local regulations and the respective manufacturer instructions.

List of figures

Fig. 1	Type plate	22
Fig. 2	Machine overview.....	26
Fig. 3	Functional lighting	27
Fig. 4	Connections of coffee machine and additional unit	28
Fig. 5	Overview of external operating elements	29
Fig. 6	Machine operating elements.....	29
Fig. 7	Bean hoppers with integrated manual inlet.....	30
Fig. 8	Overview: user interface	30
Fig. 9	Overview: operating functions on the interface	31
Fig. 10	Schaerer Coffee Soul with 10-inch display	31
Fig. 11	Schaerer Coffee Soul with 12-inch display	32
Fig. 12	Automatic height-adjustable beverage outlet.....	32
Fig. 13	Steam wand	33
Fig. 14	Hot water outlet	34
Fig. 15	Beverage dispensing: Hot additional water (red), coffee beverage (brown)	34
Fig. 16	Equipment with second grinder and powder system.....	35
Fig. 17	Powder system	35
Fig. 18	Operating elements on mixing cup for powder or topping system	36
Fig. 19	Twin powder system	36
Fig. 20	Operating elements on the Flavour Point	37
Fig. 21	Right/Left side cooling unit	37
Fig. 22	Overview of the side cooling unit.....	38
Fig. 23	Side cooling unit for Centre Milk (CM)	38
Fig. 24	Under-counter cooling unit	39
Fig. 25	Under-machine cooling unit.....	39
Fig. 26	Under-machine cooling unit overview.....	40
Fig. 27	CAN connections.....	40
Fig. 28	Cup & Cool	41
Fig. 29	Cup & Cool front side with open cooling unit.....	41
Fig. 30	Back [Cup & Cool].....	42
Fig. 31	Lockable bean hoppers	42
Fig. 32	Easy access operating unit.....	43
Fig. 33	Decor elements.....	43
Fig. 34	External waste water and drinking water tank	44
Fig. 35	Under-counter grounds disposal	44
Fig. 36	Machine feet.....	45
Fig. 37	Cup positioning aid	45
Fig. 38	cup warmer	46
Fig. 39	Overview of cup warmer	46
Fig. 40	ProCare overview.....	47
Fig. 41	Drawer with pouches	48
Fig. 42	Accessories included in delivery	53

Fig. 43	External drinking and waste water tank	57
Fig. 44	Assemble drip tray.....	57
Fig. 45	Inserting milk hose into squeeze valve (Single Milk).....	58
Fig. 46	Inserting milk hoses into squeeze valves (Twin Milk).....	58
Fig. 47	Fastening ProCare unit to machine	59
Fig. 48	Assignment of hose connections.....	60
Fig. 49	Setting hose length for ProCare unit	60
Fig. 50	Milk hose in cooling unit.....	61
Fig. 51	Cable connections.....	61
Fig. 52	CAN bus connections from the machine to optional accessories (example displays).....	62
Fig. 53	Flavour Point SOUL hose connection.....	63
Fig. 54	Labeling example for hose connections from syrup bottle to syrup pump.....	64
Fig. 55	Bean hoppers and powder containers with maximum fill level	66
Fig. 56	Bean hoppers and powder containers with maximum fill level	67
Fig. 57	External drinking water tank.....	67
Fig. 58	Filling side cooling unit.....	68
Fig. 59	Filling Cup & Cool / UM-CU / UC-CU	69
Fig. 60	Filling Flavour Point.....	69
Fig. 61	Opening operating unit	70
Fig. 62	Operating unit closed and opened.....	71
Fig. 63	Unlocking bean hoppers and powder containers	72
Fig. 64	Pulling out drawer with collecting tray	73
Fig. 65	Removing cleaning pouches.....	73
Fig. 66	Inserting drawer	74
Fig. 67	ProCare BLUE example: changing cleaning pouch.....	74
Fig. 68	Display of the remaining content	75
Fig. 69	Switching on machine.....	76
Fig. 70	Switching on Flavour Point.....	77
Fig. 71	Positioning beverage outlet.....	79
Fig. 72	Functions in Guest mode	81
Fig. 73	Functions in Staff mode.....	82
Fig. 74	Functions in Frequent user mode	84
Fig. 75	Guest and Frequent user mode: Scrolling to beverage.....	85
Fig. 76	Staff mode: Direction selection of beverage group	86
Fig. 77	Beverage preselection in the left menu	86
Fig. 78	Beverage types.....	87
Fig. 79	Guest mode: Determining beverage modification sequentially.....	87
Fig. 80	Selection of beverage	88
Fig. 81	Selection of beverage size	88
Fig. 82	Selection of coffee type.....	88
Fig. 83	Selection of ingredients.....	88
Fig. 84	Direct beverage modification in Staff mode.....	89
Fig. 85	Direct beverage modification in Frequent user mode	89
Fig. 86	Beverage modification screen.....	90
Fig. 87	Screen showing list of preselected beverages [Staff mode with milk]	91
Fig. 88	Dispensing additional beverage	91

Fig. 89	Positioning cup/mug animation is shown in the display.....	93
Fig. 90	Button for payment.....	93
Fig. 91	Instruction for payment.....	94
Fig. 92	Beverage ready for dispensing.....	94
Fig. 93	Guest and Frequent user mode: Canceling beverage dispensing.....	95
Fig. 94	Progress (Staff mode).....	95
Fig. 95	Display of Beverage dispensing completed.....	96
Fig. 96	Guest mode and Frequent user mode: canceling beverage dispensing.....	96
Fig. 97	Staff mode: canceling beverage dispensing.....	97
Fig. 98	Instruction for adding ground coffee.....	98
Fig. 99	Navigation in Guest mode with arrow buttons.....	99
Fig. 100	Types of display of the beverage buttons.....	100
Fig. 101	Small and extra large beverage display.....	100
Fig. 102	Simple error message.....	101
Fig. 103	Specific error message screen.....	101
Fig. 104	Service menu button with messages.....	102
Fig. 105	Screen for functions in the Service menu.....	103
Fig. 106	Quick info.....	103
Fig. 107	Not logged in button.....	104
Fig. 108	Profiles dialog.....	104
Fig. 109	Not logged in button.....	105
Fig. 110	Cleaning button.....	106
Fig. 111	Maintenance overdue.....	106
Fig. 112	Ingredient management button.....	106
Fig. 113	Activate milk system.....	106
Fig. 114	Bottle change.....	107
Fig. 115	Start pump.....	107
Fig. 116	Error message buttons.....	107
Fig. 117	Back to user interface.....	108
Fig. 118	Calling up system information.....	108
Fig. 119	Calling up beverage dispensing history.....	108
Fig. 120	Beverage dispensing history dialog.....	109
Fig. 121	Calling up settings.....	109
Fig. 122	Start rinsing button.....	109
Fig. 123	Touch screen cleaning button.....	110
Fig. 124	Switch on quick info button.....	110
Fig. 125	Activate Free vending mode button.....	110
Fig. 126	Switch-off button.....	110
Fig. 127	Emptying grounds container.....	111
Fig. 128	External waste water tank.....	112
Fig. 129	Start rinsing button.....	113
Fig. 130	Switch-off button.....	113
Fig. 131	Time window for cleaning.....	119
Fig. 132	Start rinsing button.....	122
Fig. 133	Cleaning button.....	123
Fig. 134	Screen with selection of cleaning types.....	123

Fig. 135	The Service menu button with pending cleaning	124
Fig. 136	Opening scheduled cleaning.....	124
Fig. 137	Dialog for cleaning according to cleaning schedule	124
Fig. 138	Start dialogue for cleaning programme.....	125
Fig. 139	Removing grounds container	125
Fig. 140	Reinserting grounds container.....	126
Fig. 141	Removing beverage outlet cover	126
Fig. 142	Inserting cleaning tablet.....	127
Fig. 143	Milkpure powder cleaning powder in sachet	127
Fig. 144	Cleaning milk container (optional)	127
Fig. 145	Pouring cleaning product into cleaning container.....	128
Fig. 146	Lifting operating panel.....	128
Fig. 147	Pulling out mixing cup	129
Fig. 148	Cleaning mixing cup	129
Fig. 149	Inserting mixing cup	129
Fig. 150	Progress screen for cleaning	130
Fig. 151	Removing cleaning container	130
Fig. 152	Activate milk system.....	131
Fig. 153	Inserting milk container	131
Fig. 154	Milk system is switched on.....	132
Fig. 155	The Service menu button with pending cleaning	132
Fig. 156	Opening scheduled cleaning.....	132
Fig. 157	Dialog for cleaning according to cleaning schedule	133
Fig. 158	Connecting milk hoses to Plug&Clean connections	133
Fig. 159	Start dialogue for cleaning programme.....	134
Fig. 160	Removing grounds container	134
Fig. 161	Reinserting grounds container.....	135
Fig. 162	Removing beverage outlet cover	135
Fig. 163	Lifting operating panel.....	136
Fig. 164	Pulling out mixing cup	136
Fig. 165	Cleaning mixing cup	136
Fig. 166	Inserting mixing cup	137
Fig. 167	Progress screen for cleaning	137
Fig. 168	Removing milk hoses from Plug & Clean connections.....	138
Fig. 169	Inserting milk container	138
Fig. 170	Milk system is switched on.....	139
Fig. 171	Additional cleaning button.....	139
Fig. 172	Dialog for additional cleaning without ProCare.....	140
Fig. 173	Dialogue for additional cleaning with ProCare	140
Fig. 174	Plug & Clean dialog	141
Fig. 175	Removing milk hoses from Plug & Clean connections.....	141
Fig. 176	Inserting milk container	141
Fig. 177	Milk system is switched on.....	142
Fig. 178	Screen with selection of cleaning types	143
Fig. 179	Place cleaning container under the hot water outlet dialog	143
Fig. 180	Filling cleaning container with hot water.....	143

Fig. 181	Drain hoses	144
Fig. 182	Connecting cleaning container to Flavour Point	144
Fig. 183	Flavour Point cleaning process is running	144
Fig. 184	Removing cleaning container again	145
Fig. 185	Filling of syrup hoses	145
Fig. 186	Call up of cleaning settings	146
Fig. 187	Screen with the cleaning settings	147
Fig. 188	Cleaning task schedule	147
Fig. 189	Creating cleaning task	148
Fig. 190	Selecting settings for cleaning task	148
Fig. 191	Selecting time for cleaning	149
Fig. 192	Remove grounds container dialog	150
Fig. 193	Cleaning brewing chamber	151
Fig. 194	Cleaning drip tray and drip grid	152
Fig. 195	Cleaning milk container	153
Fig. 196	Cleaning cooling unit	153
Fig. 197	Defrosting cooling unit	154
Fig. 198	Touch screen cleaning button	155
Fig. 199	Wiping milk remains off	156
Fig. 200	Rotating steam wand to the front	156
Fig. 201	Supersteam steam wand (left), Powersteam steam wand (right)	157
Fig. 202	Steam probe	157
Fig. 203	Supersteam steam wand end position (left), Powersteam steam wand end position (right)	158
Fig. 204	External drinking water tank	159
Fig. 205	External waste water tank	160
Fig. 206	Clean bean hoppers	161
Fig. 207	Switch-off button	161
Fig. 208	Parts of the standard powder container (2 kg)	163
Fig. 209	Removing pin for upper toothed wheel	163
Fig. 210	Removing powder loosening unit	164
Fig. 211	Removing lower axle	164
Fig. 212	Removing powder scoop	165
Fig. 213	Removing dosing element	165
Fig. 214	Removing cap nut on feed side	166
Fig. 215	Removing supply unit	166
Fig. 216	Disassembling supply unit	166
Fig. 217	Parts of the Twin powder container (2x 1 kg)	167
Fig. 218	Removing filling aid	167
Fig. 219	Removing crossbars	168
Fig. 220	Removing toothed wheel axis	168
Fig. 221	Removing powder scoop and toothed wheel	169
Fig. 222	Removing powder loosening unit	169
Fig. 223	Removing dosing element	170
Fig. 224	Remove drive holder	170
Fig. 225	Removing supply unit	170
Fig. 226	Disassembling supply unit	171

Fig. 227	Switch-off button	171
Fig. 228	Beverage outlet bottom cover removal.....	172
Fig. 229	Switch-off button	172
Fig. 230	Calling up maintenance intervals.....	175
Fig. 231	Maintenance intervals screen	176
Fig. 232	Confirming maintenance	176
Fig. 233	Confirmation dialogue for completed maintenance work (example).....	176
Fig. 234	Uptime! decalcification cartridge	179
Fig. 235	Descaling screen	180
Fig. 236	Selecting maintenance intervals	181
Fig. 237	Maintenance intervals: Selecting pending descaling	181
Fig. 238	Unpacking descaling cartridge.....	181
Fig. 239	Removing grounds container	182
Fig. 240	Insert descaling cartridge	182
Fig. 241	Insert grounds container screen.....	183
Fig. 242	Removing milk container.....	183
Fig. 243	Inserting cleaning container.....	183
Fig. 244	Positioning beverage outlet and steam wand	184
Fig. 245	Starting descaling.....	184
Fig. 246	Progress display for descaling.....	185
Fig. 247	Removing descaling cartridge.....	185
Fig. 248	Removing and emptying cleaning container	186
Fig. 249	Inserting milk container	186
Fig. 250	Removing grounds container	187
Fig. 251	Connecting milk hoses to Plug & Clean.....	188
Fig. 252	Progress display for descaling	188
Fig. 253	Removing milk hoses from Plug & Clean	189
Fig. 254	Machine configuration settings menu.....	191
Fig. 255	Structure tree (statistics)	191
Fig. 256	Input field	191
Fig. 257	Virtual keyboard.....	192
Fig. 258	Entering parameter values.....	192
Fig. 259	Factory setting for date and time	192
Fig. 260	Position of the USB interface	192
Fig. 261	Settings for the grinder/brewing unit.....	197
Fig. 262	Settings for the milk system.....	198
Fig. 263	Settings for Flavour Point.....	201
Fig. 264	Configuring software	201
Fig. 265	Configuring language	202
Fig. 266	Displaying date, time and time zone	202
Fig. 267	Dialog for adding a switch-on time or switch-off time	202
Fig. 268	Beverage price button with setting dial	203
Fig. 269	Starting grinder service.....	204
Fig. 270	Grinder service screen	204
Fig. 271	Grinding level adjustment: Removing old ground coffee.....	205
Fig. 272	Adjust grinding level: grind for grind level assessment.....	206

Fig. 273	Calibrate grinder.....	207
Fig. 274	Starting grinder service.....	207
Fig. 275	Grinder service screen.....	208
Fig. 276	Grinding level adjustment: Removing old ground coffee.....	209
Fig. 277	Adjust grinding level: grind for grind level assessment.....	209
Fig. 278	Adjust grinding level: move grinding discs.....	210
Fig. 279	Calibrate grinder.....	211
Fig. 280	Grinder initialization.....	211
Fig. 281	Position of the USB interface.....	212
Fig. 282	Buttons for resetting.....	213
Fig. 283	Buttons for resetting.....	213
Fig. 284	Button for Info menu.....	214
Fig. 285	Versions.....	214
Fig. 286	Machine counters.....	215
Fig. 287	Beverage statistics.....	216
Fig. 288	Cleaning statistics.....	216
Fig. 289	Maintenance statistics.....	217
Fig. 290	Beverage dispensing statistics.....	218
Fig. 291	Water hardness statistics.....	218
Fig. 292	Machine payment statistics.....	219
Fig. 293	Beverage accounting statistics.....	220
Fig. 294	Simple error message.....	221
Fig. 295	Screen with error message.....	222
Fig. 296	Area with error message.....	222
Fig. 297	Service menu button with messages.....	222
Fig. 298	Service menu with error message.....	223

