

# SOUL

## Operating instructions



## Legal notice

**Published by**

Schaerer AG, P.O. Box 336, Niedermattstrasse 3b, CH-4528 Zuchwil

**Edition**

09.2024

**Concept and editorial department**

Schaerer AG, P.O. Box 336, Niedermattstrasse 3b, CH-4528 Zuchwil

**Copyright ©**

Schaerer AG, P.O. Box 336, Niedermattstrasse 3b, CH-4528 Zuchwil

This document is protected by copyright. All rights are reserved. The reproduction, distribution or transmission of this document, as well as the transmission via electronic systems or translation into another language, are not permitted without the written consent of Schaerer AG. This applies to both the entire document and individual excerpts thereof. The contents of the document are based on the most current data available at the time of printing. Schaerer AG reserves the right to make changes at any time without further notice. All images, figures and display messages in this manual are only shown by way of example. Due to the wide variety of possible options, each individual machine may differ from the devices depicted herein. Schaerer AG is only liable for the contents of the original German document.

# Table of Contents

1	Safety.....	8
1.1	Signs and symbols.....	8
1.1.1	Safety notes.....	8
1.1.2	Warning symbols used.....	8
1.1.3	Prohibition symbols used.....	9
1.2	Intended use.....	9
1.3	Foreseeable misuse.....	9
1.4	Operator responsibilities.....	10
1.5	Staff requirements.....	10
1.6	Residual risks.....	11
1.6.1	Risk of electrocution.....	11
1.6.2	Danger from cleaning products.....	11
1.6.3	Danger from allergies.....	12
1.6.4	Danger from batteries.....	12
1.6.5	Danger from heat.....	14
1.6.6	Danger from mechanics.....	14
1.7	Danger of property damage.....	15
2	Technical data.....	16
2.1	Beverage types and output.....	16
2.2	Machine data.....	17
2.3	On-site mains connection.....	18
2.4	Water connection values.....	19
2.5	Ambient conditions.....	20
2.6	Serial plate.....	20
3	Compliance information.....	22
3.1	Manufacturer's address.....	22
3.2	Applied standards.....	22
4	Product description.....	24
4.1	Overview.....	24
4.2	Connections and interfaces.....	25
4.3	Operating elements.....	26
4.3.1	Machine operating elements.....	26
4.3.2	Machine operating elements.....	27
4.3.3	Bean hoppers with integrated manual inlet.....	27
4.3.4	User interface.....	28
4.4	Equipment variants.....	30
4.4.1	Schaerer Coffee Soul with 10-inch display.....	30
4.4.2	Schaerer Coffee Soul with 12-inch display.....	31
4.4.3	Ambient light with function.....	32
4.4.4	Automatic height-adjustable beverage outlet (AHA).....	33
4.4.5	Drip tray with operating unit.....	33
4.4.6	Steam wand.....	34
4.4.7	Hot water outlet.....	35
4.4.8	Additional water for preparing americanos.....	35
4.4.9	Brewing accelerator.....	36
4.4.10	Lockable bean hoppers.....	36
4.4.11	Additional grinders.....	37

4.4.12	Powder system 2000 g (choco or topping).....	37
4.4.13	Mixing cup for powder or topping system.....	38
4.4.14	Twin powder system.....	38
4.4.15	Décor elements.....	39
4.4.16	External waste water / drinking water tank monitored.....	39
4.4.17	Under-counter grounds disposal.....	40
4.4.18	Machine feet.....	41
4.4.19	Cup positioning aid.....	42
4.4.20	Best Foam™ (fresh milk system).....	42
4.4.21	Hot & Cold (cold beverages).....	43
4.4.22	Schaerer Coffee Link (data exchange).....	43
4.4.23	Payment systems.....	43
4.4.24	Flavour Point.....	44
4.4.25	Operating elements on the Flavour Point.....	45
4.4.26	SOUL with side cooling unit.....	45
4.4.27	Side cooling unit for Centre Milk (CM).....	46
4.4.28	Under-machine cooling unit.....	47
4.4.29	Under-counter cooling unit (UC).....	47
4.4.30	Cooling unit operating elements.....	48
4.4.31	Cup warmer.....	48
4.4.32	Cup & Cool.....	49
4.4.33	Cup & Cool, cup warmer operating elements.....	50
4.4.34	ProCare overview.....	51
5	Transport.....	53
5.1	Scope of delivery and accessories.....	53
5.2	Transport conditions.....	53
6	Installation and commissioning.....	55
6.1	Unpacking.....	55
6.1.1	Unpacking machine.....	55
6.1.2	Unpacking accessories.....	55
6.2	Setup.....	56
6.2.1	Installation conditions.....	56
6.2.2	Climatic conditions.....	56
6.3	Installation.....	56
6.3.1	Connecting power supply.....	57
6.3.2	Connecting water supply.....	58
6.3.3	Assembling drip tray.....	60
6.3.4	Connecting ProCare unit.....	60
6.3.5	Connecting milk system.....	63
6.4	Installing optional accessories.....	64
6.4.1	Connecting optional accessories to power supply.....	64
6.4.2	Establishing communication connection (CAN bus).....	65
6.4.3	Connecting 4-fold Flavour Point UC (syrup module) (option).....	65
6.5	Display-guided commissioning.....	66
7	Setup and adjustment.....	68
7.1	Converting milk system to the left.....	68
7.1.1	Required components and tools.....	68
7.1.2	Required conversion steps.....	68
7.1.3	Preparation.....	68

7.1.4	Converting side strip openings.....	69
7.1.5	Laying milk hoses in the machine to the left.....	70
7.1.6	Assembling right housing and left milk hose guide.....	71
<b>8</b>	<b>Operation.....</b>	<b>75</b>
8.1	Recurring additional tasks.....	75
8.1.1	Filling bean hopper.....	75
8.1.2	Filling powder container.....	75
8.1.3	Refilling water.....	76
8.1.4	Filling BestFoam™ milk system.....	77
8.1.5	Filling the Flavour Point (optional) or changing bottles.....	78
8.1.6	Opening and closing user panel.....	79
8.1.7	Removing bean hoppers and powder container.....	80
8.1.8	Inserting ProCare cleaning bags.....	81
8.2	Switching on.....	84
8.2.1	Check before switching on.....	84
8.2.2	Switching on machine.....	85
8.2.3	Switching on Cup & Cool/cup warmer (option).....	86
8.2.4	Switching on side cooling unit (optional).....	86
8.2.5	Switching on under-counter or under-machine cooling unit (optional).....	87
8.2.6	Switching on the Flavour Point (optional).....	88
8.3	Positioning beverage outlet.....	88
8.4	Operating modes.....	89
8.4.1	Functions of operating mode.....	89
8.4.2	Guest mode.....	90
8.4.3	Staff mode.....	92
8.4.4	Frequent user mode.....	94
8.5	Beverage supply.....	96
8.5.1	Selecting beverage.....	96
8.5.2	Modifying beverage.....	98
8.5.3	Preselecting double beverage.....	100
8.5.4	Dispensing preselected beverages multiple times.....	101
8.5.5	Preselecting decaffeinated coffee.....	102
8.5.6	Barista preselection.....	103
8.5.7	Positioning cup/mug.....	103
8.5.8	Paying for beverage.....	104
8.5.9	Dispensing beverage.....	104
8.5.10	Progress display for beverage dispensing.....	105
8.5.11	Completion of beverage.....	106
8.5.12	Cancelling beverage dispensing.....	106
8.6	Using manual inlet.....	107
8.7	Generic functions of the user interface.....	108
8.7.1	Navigation in the interface.....	108
8.7.2	Display of beverages.....	109
8.7.3	Pending error message or instruction for action.....	110
8.7.4	Error messages (simple).....	110
8.7.5	Error messages (specific).....	111
8.8	Service menu.....	111
8.8.1	Service menu button.....	111
8.8.2	Service menu overview.....	112
8.8.3	Quick info.....	113

8.8.4	Profiles (log in / log out).....	114
8.8.5	Scope of functions.....	116
8.9	Emptying.....	123
8.9.1	Emptying grounds container.....	123
8.9.2	Emptying external waste water tank.....	124
8.10	Switch-off.....	125
8.10.1	Switching machine to standby.....	125
8.10.2	Lengthy downtimes (more than 1 week).....	126
8.10.3	Switching off optional accessories.....	126
9	<b>Cleaning.....</b>	<b>128</b>
9.1	Cleaning requirements and conditions.....	128
9.2	Cleaning products.....	128
9.3	Cleaning levels.....	130
9.4	Cleaning intervals.....	131
9.5	Machine rinsing.....	133
9.5.1	Automatic switch on/off rinsing.....	133
9.5.2	Configured rinsing processes.....	133
9.5.3	Manual rinsing processes (service menu).....	134
9.6	Display-guided cleaning.....	134
9.6.1	Required tools.....	135
9.6.2	Starting scheduled cleaning.....	136
9.6.3	Starting scheduled cleaning with ProCare.....	146
9.6.4	Additional cleaning.....	153
9.6.5	ProCare: Cleaning (Plug&Clean) milk hose piece.....	155
9.6.6	Display-guided cleaning: Flavour Point (option).....	156
9.7	Cleaning schedule.....	161
9.7.1	Calling up cleaning schedule.....	161
9.7.2	Setting cleaning times.....	162
9.8	Manual cleaning.....	164
9.8.1	Cleaning grounds container.....	164
9.8.2	Cleaning brewing chamber.....	165
9.8.3	Cleaning drip tray and drip grid.....	166
9.8.4	Cleaning milk container.....	166
9.8.5	Cleaning cooling unit (optional).....	167
9.8.6	Defrosting cooling unit (optional).....	168
9.8.7	Cleaning touch screen.....	168
9.8.8	Cleaning steam wand (optional).....	169
9.8.9	Cleaning external drinking water tank.....	170
9.8.10	Cleaning external waste water tank.....	170
9.8.11	Cleaning optional accessories.....	171
9.8.12	Cleaning bean hoppers.....	171
9.8.13	Cleaning lower beverage outlet.....	172
9.8.14	Cleaning powder container (option).....	173
9.8.15	Cleaning outer surfaces.....	183
10	<b>Maintenance.....</b>	<b>184</b>
10.1	Maintenance work.....	184
10.1.1	Maintenance intervals.....	184
10.1.2	Having maintenance work done and resetting counter.....	184
10.1.3	Replacing external water filter (optional).....	186
10.2	Descaling.....	187

10.2.1	Required descaling material.....	187
10.2.2	Uptime! decalcification cartridge.....	188
10.2.3	Disposing of decalcification cartridge.....	194
10.2.4	Decalcifying with ProCare.....	194
11	Programming.....	195
11.1	Navigation elements.....	195
11.2	USB interface.....	199
11.3	Profiles and authorisations.....	199
11.3.1	Caretaker profile.....	199
11.3.2	Bookkeeper profile.....	200
11.3.3	Facilities manager profile.....	201
11.3.4	Quality manager profile.....	201
11.3.5	Machine operator profile.....	202
11.4	Machine configuration.....	202
11.4.1	"System" settings.....	202
11.4.2	"Configuration" settings.....	207
11.4.3	"Service" settings.....	210
11.4.4	"Info" settings.....	220
11.4.5	Saving changes and loading them into the machine.....	227
12	Troubleshooting.....	228
12.1	Meaning of the functional lighting.....	228
12.2	Messages in display.....	228
12.3	Faults with display messages.....	230
12.3.1	"Malfunction" display message.....	230
12.3.2	"Fault" display message.....	234
12.3.3	"Instruction" display message.....	235
12.3.4	"Note" display message.....	236
13	Disassembly.....	238
14	Disposal.....	239

# 1 Safety

## 1.1 Signs and symbols

### 1.1.1 Safety notes



#### DANGER

**An imminently dangerous situation that may result in death or serious injury.**

The measures described for preventing this danger must be adhered to without fail.



#### WARNING

**A generally dangerous situation that may result in serious injury.**

The measures described for preventing this danger must be adhered to without fail.



#### CAUTION

**A generally dangerous situation that may result in minor injury.**

The measures described for preventing this danger must be adhered to without fail.









#### ADVICE

**There is a situation that may result in damage to the machine.**

The measures described for preventing this danger must be adhered to without fail.

### 1.1.2 Warning symbols used

Symbols for danger and rules can appear both in the operating instructions and on the machine.

Charac- ters	Type of danger	Charac- ters	Type of danger
	Warning of hot fluids		Warning of hot surface
	Warning of hot steam		Warning of dangerous electrical voltage
	Warning of poisonous substances		Warning of hand injuries

### 1.1.3 Prohibition symbols used

Charac- ters	Significance	Charac- ters	Significance
	Read documentation!		Wear safety gloves!
	Wear safety goggles!		Wash your hands!
	Disconnect the power plug!		

## 1.2 Intended use

The machine is designed to dispense coffee beverages, hot water, milk and powder beverages (topping & chocolate) and flavours (syrup) in different versions and combinations into cups, mugs, glasses or jugs.

The bean hoppers may only be filled with coffee beans, the powder container only with choco powder, the milk container only with milk and the manual inlet only with ground coffee.

This machine is intended for commercial use in hotels, restaurants and similar establishments. The machine can be installed at self-service locations and operated without supervision. The machine can be used in businesses, offices and other similar work environments, hotels, motels and bed and breakfast establishments and can be operated by non-experts and customers.

Use for these purposes is subject to these operating instructions. In legal terms, any other use is not an intended use. The manufacturer accepts no liability for damage resulting from unintended use.

The machine can be used by children aged 8 and up and by persons with limited physical, sensory or mental capabilities or a lack of experience and/or knowledge, provided they are supervised or have been instructed about the safe use of the machine and understand the potential hazards resulting from said use. Children must not play with the machine. Children must also not be allowed to perform cleaning procedures or user maintenance without supervision. Only have cleaning and user maintenance done by persons who have knowledge of and practical experience with the device, particularly when it comes to service and hygiene.



Use is subject to the **General Terms and Conditions** of Schaerer AG and these operating instructions. In legal terms, any other use is not an intended use. The manufacturer accepts no liability for damage resulting from unintended use.

## 1.3 Foreseeable misuse

Any use of the machine beyond its intended use or in a different manner is considered misuse and can lead to dangerous situations. Improper handling of the machine can lead to injuries.

- ▶ Read the operating instructions carefully before use.
- ▶ Only allow qualified service staff access to the service area of the machine and optional accessories.
- ▶ Only have cleaning and user maintenance done by persons who have knowledge of and practical experience with the machine, particularly when it comes to service and hygiene.
- ▶ Have the machine supervised by trained staff in Self-service mode and in operation by staff so that they are available to the user for questions and to ensure compliance with the cleaning and maintenance measures.
- ▶ Use only insufficiently cooled milk.

- ▶ Only use the optional steam wand to foam milk.
- ▶ Never modify the safety devices of the machine.
- ▶ Only use the machine if it is working properly and is not damaged.
- ▶ Only pour coffee beans into the bean hoppers.
- ▶ Only pour coffee machine powder into the powder container.
- ▶ Only pour milk into the milk container.
- ▶ Only pour ground coffee into the manual inlet or insert a cleaning tablet during cleaning.

## 1.4 Operator responsibilities

The operating company must ensure that the machine undergoes regular maintenance and that the safety devices are checked regularly by a Schaerer AG service partner, a representative thereof, or other authorised persons. Schaerer AG must be notified in writing of any defects within 30 days! For hidden defects, this period is extended to 12 months from the date of installation (work report, handover report), but no later than 18 months after the product leaves the factory in Zuchwil.

Damaged or defective safety-relevant parts such as safety valves, safety thermostats, boilers etc. must be replaced and not be repaired under any circumstances.

The operator is responsible for compliance with the maintenance regulations.

## 1.5 Staff requirements



### WARNING

#### **Risk of injury due to insufficient qualification!**

Improper handling can lead to personal injury and property damage.  
All work may only be carried out by qualified staff.

Only people who can be expected to carry out their work reliably are authorised to work as staff. Persons whose ability to react is impaired, e.g. by drugs, alcohol or medication, are not authorised to work as staff.

When selecting staff, the age and occupation-specific regulations applicable at the place of use must be observed.

The following qualifications are specified in the operating instructions for various areas of activity:

#### **Instructed person**

Has been instructed by the operator about the tasks assigned to him/her and the possible dangers in the event of improper behaviour.

#### **Specialist staff**

Is considered to be someone who is able to do the work given to him/her and independently identify and prevent possible dangers as a result of his/her specialist training, knowledge and experience, as well as his/her knowledge of the relevant stipulations.

#### **Service staff**

Is a qualified person who has been specially trained by the manufacturer or operator for service tasks.

#### **Qualified electrician**

Is considered to be someone who is able to do work on electrical system and independently identify and prevent possible dangers as a result of his/her specialist training, knowledge and experience, as well as his/her knowledge of the relevant standards and stipulations. The qualified electrician is trained for the specific location where he/she is working and knows the relevant standards and regulations.

## 1.6 Residual risks

Maximum safety is one of the most important features of Schaerer AG products. The effectiveness of the safety devices can only be ensured if the chapter containing precautions to avoid injury and danger to health are adhered to.



These safety notes can be requested from Schaerer AG or downloaded directly from the Media Pool on the website ([schaerer.com/member](https://www.schaerer.com/member)).

### 1.6.1 Risk of electrocution



**DANGER**

#### **Risk of death due to electrocution!**



Improper handling of electrical equipment can result in electrocution. There is a risk of death.

- ▶ Only have work on electrical systems performed by qualified electricians.
- ▶ Connect the device to a secured circuit.
- ▶ Route the connection via a residual current circuit breaker.
- ▶ Observe the relevant guidelines on low voltage and country-specific and local safety regulations and laws.
- ▶ Earth the connection in line with the regulations and secure it against electric shock.
- ▶ Make sure that the mains voltage corresponds to the specifications on the serial plate of the device.
- ▶ Never touch energised parts.
- ▶ Before carrying out service work, always switch off the main switch and disconnect the machine from the mains power supply.
- ▶ Make sure that all poles of the device can be disconnected from the mains power supply. Disconnected connections must be visible from the site of the device at all times, and a locking device must be used to ensure they stay disconnected.
- ▶ Only have the connection cable replaced by qualified service staff.

### 1.6.2 Danger from cleaning products



Before using cleaning products, read the information on the cleaning product packaging carefully. If it is missing, the safety data sheet can be requested from the sales company (see cleaning product packaging).

**WARNING****Danger of poisoning from cleaning products!**

There is a risk of poisoning if cleaning products are ingested.

- ▶ Keep the cleaning products out of reach of children and unauthorised persons.
- ▶ Do not ingest cleaning products.
- ▶ Never mix cleaning products with other chemicals.
- ▶ Only use the cleaning and descaling products for the intended purpose (see label).
- ▶ Do not eat or drink while using the cleaning products.
- ▶ While using the cleaning products, make sure that there is good ventilation and air circulation around you.
- ▶ Wear safety gloves when handling cleaning products.
- ▶ Wash your hands thoroughly after handling cleaning products.

**Emergency information:** Contact the cleaning product manufacturer (see cleaning product label) for the telephone number of the emergency information centre (Toxicological Information Centre). If your country does not have this type of institution, contact the following organisation:

Swiss Toxicological Information Centre

International calls +4144 251 51 51

Calls from Switzerland 145

Internet [www.toxi.ch](http://www.toxi.ch)

### 1.6.3 Danger from allergies

**CAUTION****Health hazard due to additives!**

Beverages containing additives or traces of additives may trigger allergies. There is a risk to health.

- ▶ In self-service operation: Observe the information sign attached to the machine. The information sign contains information about any additives used which could trigger an allergic reaction.
- ▶ When operated by staff: Inform the staff that any additional products may cause allergies.

### 1.6.4 Danger from batteries

**CAUTION****Health problems due to contaminated water!**

Improper handling of water can cause health problems.

- ▶ Make sure that the water is free of dirt and bacteria.
- ▶ Do not connect the machine to pure reverse osmosis water or other aggressive types of water.
- ▶ Make sure that the carbonate hardness is between 4 and 6 °dKH or 8 and 12 °fKH.
- ▶ Make sure that the total hardness is higher than the carbonate hardness.
- ▶ Do not exceed the maximum chlorine content of 50 mg per litre.
- ▶ Make sure that the pH value is between 6.5 and 7 (pH-neutral).

**CAUTION****Health problems due to contaminated coffee!**

Improper handling of coffee can cause health problems.

- ▶ Check the packaging for damage before opening.
- ▶ Do not add more coffee beans than will be needed for one day.
- ▶ Close the bean hopper lid immediately after filling.
- ▶ Store coffee in a cool, dry, dark place.
- ▶ Store coffee separately from cleaning products.
- ▶ Use up the oldest products first ("first in, first out" principle).
- ▶ Use coffee before the expiry date.
- ▶ Always reseal packages properly after opening to ensure that the contents remain fresh and are protected from contamination.

**CAUTION****Health problems due to contaminated/incorrect milk!**

Improper handling of milk can cause health problems.

- ▶ Do not use raw milk.
- ▶ Only use pasteurised or UHT milk.
- ▶ Use only homogenised milk.
- ▶ Use pre-cooled milk with a temperature sensor between 3 °C (37,4 °F) and 5 °C (41 °F).
- ▶ When working with milk, wear protective gloves.
- ▶ Use milk directly from the original packaging.
- ▶ Never refill milk. Always clean the container thoroughly before filling.
- ▶ Check the packaging for damage before opening.
- ▶ Do not add more milk than will be needed for one day.
- ▶ Close the milk container cover and cooling unit (internal and external) immediately after filling.
- ▶ Store milk in a dry and dark place at a maximum temperature of 7 °C (44,6 °F).
- ▶ Store milk separately from cleaning products.
- ▶ Use up the oldest products first ("first in, first out" principle).
- ▶ Use milk before the expiry date.
- ▶ Always reseal packages properly after opening to ensure that the contents remain fresh and are protected from contamination.

**CAUTION****Health problems due to coffee machine powder!**

Improper use of coffee machine powder can be hazardous to health.

- ▶ Check the packaging for damage before opening.
- ▶ Do not add more coffee machine powder than will be needed for one day.
- ▶ Close the powder container lid immediately after filling.
- ▶ Store coffee machine powder in a cool, dry, dark place.
- ▶ Store coffee machine powder separately from cleaning products.
- ▶ Use up the oldest products first ("first in, first out" principle).
- ▶ Use coffee machine powder before the expiry date.
- ▶ Always reseal packages properly after opening to ensure that the contents remain fresh and are protected from contamination.

### 1.6.5 Danger from heat



#### CAUTION

##### Scalding danger due to hot fluids!

There is a risk of scalding in the area where beverages, hot water and steam are dispensed.

- ▶ Never reach under the dispensing points while the machine is dispensing or during cleaning.



#### CAUTION

##### Hot surface!

The dispensing points and the brewing unit may be hot.

- ▶ Never touch hot machine parts.
- ▶ Do not touch any part of the beverage outlet except the grips provided for this purpose.
- ▶ Only clean the brewing unit when the machine has cooled down.

### 1.6.6 Danger from mechanics



#### CAUTION

##### Danger of crushing caused by moving components!

The beverage outlet and the user panel can be moved manually. During operation, the grinders and the brewing unit move. When working with moving components, there is a risk of fingers or hands becoming trapped.

- ▶ Do not touch any part of the beverage outlet except the grips provided for this purpose.
- ▶ Always push the user panel up or down using both hands.
- ▶ While the machine is switched on, never reach into the bean hoppers or into the opening of the brewing unit.

## 1.7 Danger of property damage



### ADVICE

#### Material damage due to improper handling of the machine!

Improper handling of the machine can lead to property damage or contamination.

- ▶ For water with a carbonate hardness above 6 °dKH, install a limescale filter. Otherwise damage may occur due to calcification.
- ▶ Do not operate the machine if the water supply is blocked. Otherwise, the boilers will not be re-filled and the pump will run dry.
- ▶ Schaerer AG recommends installing a water stop valve on the manufacturer side in the water connection to prevent water damage in case of hose breakage.
- ▶ After extended downtime (for instance company holidays), the machine must be cleaned before it is put back into operation.
- ▶ Protect the machine from weather elements (frost, moisture, etc.).
- ▶ In the event of malfunctions, observe the information in the **Troubleshooting** chapter and call in a qualified service technician if necessary.
- ▶ Only use original Schaerer AG spare parts.
- ▶ Report any noticeable damage or leaks immediately to an authorised service partner and have any affected parts replaced or repaired.
- ▶ Never spray the machine with water or clean it with a steam cleaner.
- ▶ Do not install the machine on a surface where a water jet might be used.
- ▶ When using caramelised coffee (flavoured coffee), clean the brewing unit twice daily.
- ▶ Only fill the bean hoppers with coffee beans, the powder containers with coffee machine powder, the milk containers with milk and the manual inlet with ground coffee (or cleaning tabs during cleaning).
- ▶ Never use freeze-dried coffee. This causes the brewing unit to stick.
- ▶ If the machine and/or auxiliary equipment is transported at temperatures below 10°C, store the machine and/or auxiliary equipment at room temperature for three hours before connecting the machine and/or auxiliary equipment to the power supply and switching them on. Otherwise condensation may cause short circuits or damage electrical components.
- ▶ Always use the new hose set supplied with the machine (drinking water/waste water hose). Never use old hose sets.

## 2 Technical data

### 2.1 Beverage types and output

The machine not intended for continuous dispensing of beverages for more than 45 minutes.

Depending on the machine variant and options, the following beverages can be prepared:

Max. beverage output per hour		
Espresso 50 – 60 ml	Approx. 180 cups	
Coffee 120 ml	Approx. 180 cups	
Recommended daily output		
Espresso 50 – 60 ml	Approx. 250 cups	
Coffee 120 ml	Approx. 250 cups	
Available beverages	Standard	Option
Espresso	x	
Coffee	x	
Coffee/café crème	x	
Mug (250 ml)		x
Pot (500 ml)		x
Americano <sup>AC</sup> .		x
White americano <sup>**</sup> . <sup>**</sup> . <sup>AC</sup> .		x
Latte (light/dark) <sup>*</sup> . <sup>**</sup>		x
Cappuccino <sup>*</sup> . <sup>**</sup>		x
Latte macchiato <sup>*</sup> . <sup>**</sup>		x
Espresso macchiato <sup>*</sup> . <sup>**</sup>		x
Chociatto <sup>***</sup>		x
Hot chocolate <sup>***</sup>		x
Flat white <sup>*</sup>		x
Hot milk <sup>*</sup>		x
Hot milk foam <sup>*</sup>		x
Cold milk <sup>*</sup>		x
Cold milk foam <sup>*</sup> . <sup>**</sup>		x
Best Foam™ milk foam <sup>*</sup>		x

Available beverages	Standard	Option
Hot water / External hot water	x	x
Steam		x
Powder beverages / Instant beverages		
Liquor / Coffee		x

Recommended machine equipment:

- \* With fresh milk
- \*\* With fresh milk and / or topping (milk powder)
- \*\*\* With choco
- AC Brewing accelerator
- AW Additional water

## 2.2 Machine data

Boiler nominal power*	Steam boiler	Hot water boiler
	3000 W	3000 W

\* For special equipment, see serial plate. The values specified here apply to the standard equipment.

Operating temperature	Steam boiler	Hot water boiler
Minimum operating temperature (T min.)	10 °C (50 °F)	10 °C (50 °F)
Maximum operating temperature (T max.)	192 °C (377.6 °F)	192 °C (377.6 °F)
Operating temperature	127 °C (261 °F)	95 °C (203 °F)

Overpressure	Steam boiler	Hot water boiler
Working pressure	0.25 MPa (36.26 psi)	0.8 MPa (116.03 psi)
Permissible operating overpressure (p max.)	0.5 MPa (72.52 psi)	1.2 MPa (174.04 psi)
Test overpressure	2.4 MPa (348.09 psi)	2.4 MPa (348.09 psi)

Capacities	
Drinking water capacity	Mains water supply
Bean hopper capacity	Approx. 1200#g each
Grounds container capacity	60 – 70 coffee cakes

External dimensions

Width of machine	330 mm (12.99")
Width with side cooling unit	723 mm (28.46")
Height including bean hopper and key	761 mm (29.96")
Depth	600 mm (23.62")

Weight

Empty weight	Approx. 55 kg (121 lbs)*
--------------	--------------------------

\* For special equipment, see serial plate. The values specified here apply to the standard equipment.

Noise level

Continuous sound pressure level	< 70 dB(A)*
---------------------------------	-------------

\* The A-weighted sound level (slow) and Lpa (pulses) at the operating personnel workstation is below 70 dB (A) in every operating mode.

## 2.3 On-site mains connection



The machine can be operated both on a 50 Hz mains and on a 60 Hz mains.

Mains	Connection values			On-site fuse	Connection cable Wire cross-section
1L, N, PE	220 – 240 V AC	50/60 Hz	2000 – 2400 W <sup>1)</sup>	10 – 13 A	3 x 1 mm <sup>2</sup> 3 x 17 AWG
1L, N, PE	220 – 240 V AC	50/60 Hz	3000 – 3600 W <sup>2)</sup>	16 – 30 A	3 x 1.5 mm <sup>2</sup> 3 x 15 AWG
1L, N, PE	220 – 240 V AC	50/60 Hz	6000 – 7000 W <sup>3)</sup>	30 A	3 x 4 mm <sup>2</sup> 3 x 11 AWG
2L, PE	200 V AC	60 Hz	2000 W <sup>1)</sup>	10 – 30 A	3 x 1 mm <sup>2</sup> 3 x 17 AWG
2L, PE	200 V AC	60 Hz	3000 W <sup>2)</sup>	16 – 30 A	3 x 1.5 mm <sup>2</sup> 3 x 15 AWG
2L, PE	200 V AC	60 Hz	6000 W <sup>3)</sup>	30 A	3 x 4 mm <sup>2</sup> 3 x 11 AWG
2L, PE	208 – 240 V AC	60 Hz	1900 – 2400 W <sup>1)</sup>	10 – 30 A	3 x 1 mm <sup>2</sup> 3 x 17 AWG

Mains	Connection values			On-site fuse	Connection cable Wire cross-section
2L, PE	208 – 240 V AC	60 Hz	2800 – 3600 W <sup>2)</sup>	15 – 30 A	3 x 1.5 mm <sup>2</sup> 3 x 15 AWG
2L, PE	208 – 240 V AC	60 Hz	5100 – 7000 W <sup>3)</sup>	30 A	3 x 4 mm <sup>2</sup> 3 x 11 AWG
2L, PE	200 V AC	50/60 Hz	1800 W <sup>1)</sup>	15 – 25 A	3 x 2 mm <sup>2</sup> 3 x 14 AWG
2L, PE	200 V AC	50/60 Hz	2600 W <sup>2)</sup>	15 – 25 A	3 x 2 mm <sup>2</sup> 3 x 14 AWG
3L, PE	200 V AC	60 Hz	5700 – 8700 W <sup>4)</sup>	25 – 30 A	4 x 2.5 mm <sup>2</sup> 3 x 13 AWG
3L, PE	208 – 240 V AC	60 Hz	5100 – 6400 W <sup>3)</sup>	25 – 30 A	4 x 2.5 mm <sup>2</sup> 3 x 13 AWG
3L, PE	208 – 240 V AC	60 Hz	7700 – 10300 W <sup>4)</sup>	25 – 30 A	4 x 2.5 mm <sup>2</sup> 3 x 13 AWG
3L, PE	200 V AC	50/60 Hz	4700 W <sup>3)</sup>	25 A	4 x 2.5 mm <sup>2</sup> 3 x 13 AWG
3L, PE	200 V AC	50/60 Hz	6900 W <sup>4)</sup>	25 A	4 x 2.5 mm <sup>2</sup> 3 x 13 AWG
3L, N, PE	380 – 415 V	50/60 Hz	5700 – 6400 W <sup>3)</sup>	16 – 30 A	5 x 1.5 mm <sup>2</sup> 3 x 15 AWG
3L, N, PE	380 – 415 V	50/60 Hz	8700 – 10300 W <sup>4)</sup>	16 – 30 A	5 x 1.5 mm <sup>2</sup> 3 x 15 AWG

- 1) Equipment 1 or 2 boiler with 2 kW (serial heating)
- 2) Equipment 1 or 2 boiler with 3 kW (serial heating)
- 3) Equipment 2 boiler with 3 kW (simultaneous heating)
- 4) Equipment 3 boiler with 3 kW (simultaneous heating)

## 2.4 Water connection values

Water pressure	Minimum:	0.1 MPa (14.50 psi)
	Maximum:	1.0 MPa (145.04 psi)
Water inlet temperature	Minimum:	10 °C (50 °F)
	Maximum:	30 °C (86 °F)

Water quality

Chlorine content	Maximum:	Please observe the local regulations on the maximum permitted chlorine content.
pH value	Minimum:	6.5
	Maximum:	7
Carbonate hardness (German)	Minimum:	4 °dKH
	Maximum:	6 °dKH
Carbonate hardness (French)	Minimum:	8 °fKH
	Maximum:	12 °fKH
Total hardness		> Carbonate hardness

## 2.5 Ambient conditions

Ambient temperature	Minimum:	+10 °C (50 °F)
	Maximum:	+40 °C (104 °F)
Relative humidity	Maximum:	80% RH
Height above sea level	Maximum:	2500 m (8202 ft)

## 2.6 Serial plate

Type designation	Model
SOUL 10 (SOUL)	No model versions
SOUL 12 (SOUL)	No model versions

<b>schaerer</b> <i>made in Switzerland</i>	<b>UK</b> <b>CA</b>			
<b>Designation</b>	<b>coffee machine</b>			
<b>Manufacturer</b>	Schaerer AG, Niedermattstr.3b 4528 Zuchwil, <b>Switzerland</b>			
<b>Type</b>	<b>SOUL</b>			
Nominal pressure	1.05 MPa (10.5 bar)			
main pressure	0.1 – 1.0 MPa (1-10 bar)			
Electrical Ratings	<b>380 – 415 V 3N~ (3L-N-PE)</b> <b>5700 – 6400 W 50Hz</b>			
fuse on site	<b>16 – 30 A</b> , cable min. <b>5x 1,5mm<sup>2</sup></b>			
SCIP UUID	d187db2d-934c-44a1-a2cc-ad4cb7c86335			
Article No.	040195-XXXXXXXX			
<b>Serial No.</b>	<b>2139651189</b>			

Figure: Serial plate

The serial plate is located on the front of the machine behind the right cover.

To read the data from the serial plate:

1. Pull the grounds drawer out of the machine.
2. Unfold the right cover section next to the grounds container.

In the event of a fault or warranty claim, please provide the following data from the serial plate (examples):

- Machine type
- Nominal power > e.g. 2900 ... 3400 W
- Nominal voltage > e.g. 220 ... 240 V
- Fuse value on site > e.g. 16 A
- Serial number > [YYKW XXXXXX] > e.g. 2001 XXXXXX



Another serial plate is located on the back behind the lower cover plate.

## 3 Compliance information

### 3.1 Manufacturer's address

Manufacturer	Documentation specialist
Schaerer AG P.O. Box 336 Niedermattstrasse 3b CH-4528 Zuchwil T +41 32 681 62 00 F +41 32 681 64 04 info@schaerer.com www.schaerer.com	Schaerer AG Director of R&D GBU PCM P.O. Box 336 Niedermattstrasse 3b CH-4528 Zuchwil

### 3.2 Applied standards

Schaerer AG declares herewith that this machine complies with all relevant stipulations of the specified directives. In case of any modifications of the devices that have not been approved by Schaerer, this declaration is rendered invalid. The following harmonised standards have been applied. A **DNV GL – Business Assurance** quality management system certified in accordance with ISO 9001:2015, ISO 14001:2015 and ISO 45001:2018 is used to ensure proper adherence to the requirements. Schaerer AG assumes sole responsibility for issuing this declaration of conformity.

The object of the declaration described above fulfils the requirements of directive 2011/65/EC of the European Parliament and Council from June 8, 2011 for limiting the use of certain hazardous substances in electric and electronic devices.

For CE conformity	
MD 2006/42/EC <ul style="list-style-type: none"> <li>EN 60335-1:2020-08 +A11 +AC</li> <li>EN 60335-2-75:2010-11 +A1 +A11 +A12 +A2</li> <li>EN 62233:2008</li> </ul>	EMC Directive 2014/30/EU <ul style="list-style-type: none"> <li>EN 55014-1:2018-08 +A1 +A2</li> <li>EN 55014-2:2016-01 +A1 +A2 +AC</li> <li>EN 55014-2:2016-01 +A1 +A2 +AC</li> <li>EN 61000-3-11:2021-03</li> </ul>
RoHS Directive 2011/65/EU <ul style="list-style-type: none"> <li>EN IEC 63000:2019-05</li> </ul>	RED 2014/53/EU <ul style="list-style-type: none"> <li>EN 301 489-1 V2.1.1:2017</li> <li>EN 301 489-7 V1.3.1:2005</li> <li>EN 301 489-24 V1.5.1:2010</li> </ul>
For compliance with European directives and ordinances	
WEEE Directive 2012/19/EU	POP Ordinance 2019/1021
For the EU Chemicals Regulation	
REACH Ordinance 1907/2006/EC	

## International (CB)

## Safety

- IEC 60335-1:2020-08
- IEC 60335-2-75
- BS EN 62233:2008

## EMC

- CISPR 14-1
- CISPR 14-2
- IEC 61000-3-2
- IEC 61000-3-11

CB	Scheme > International system for mutual recognition of test reports and certificates
CE	Requirements of harmonisation legislation of the European Community
CISPR	Special International Committee on Radio Interference
EC/EU	The European Community is part of the European Union consisting of EG/CFSP/PJCCM
EMC	Electromagnetic compatibility
IEC	International conformity assessment system for electrotechnical equipment and components
MD	Machinery Directive (European Parliament and Council)
POP	Regulation (EU) on persistent organic pollutants
REACH	EU chemicals regulation for "Registration, Evaluation, Authorisation and Restriction of Chemicals"
RED	European approval guidelines for radio equipment and receivers (radio communication)
RoHS	Restriction of hazardous materials
WEEE	Waste of Electrical and Electronic Equipment

## 4 Product description

### 4.1 Overview



Figure: Machine overview

- |   |  |   |                                    |
|---|--|---|------------------------------------|
| 1 | Bean hoppers and powder container (type and number depends on configuration) | 6 | Area with inner operating elements |
| 2 | User panel with touch screen 10"/12"   | 7 | Hot water dispensing (option)      |
| 3 | Dispensing area with beverage outlet and optional hot water/steam outlet     | 8 | Steam wand (option)                |
| 4 | Machine drip tray with cup positioning aid                                   | 9 | User panel closing device          |
| 5 | User panel swivelled upwards   |   |                                    |

## 4.2 Connections and interfaces

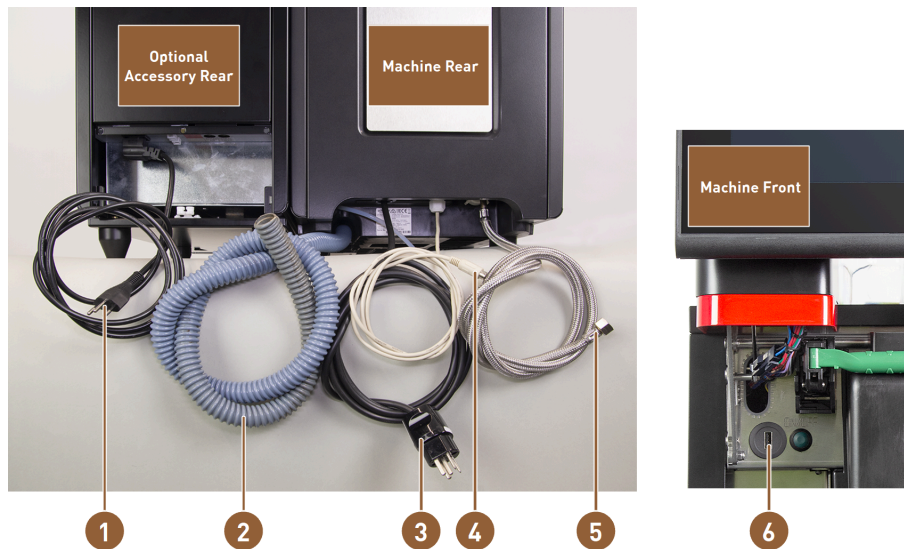

Figure: Connections for coffee machine with side cooling unit

- |  |  |
|--|--|
| <p>1 Power cable with cold device plug and country-specific mains plug for optional accessory</p> <p>2 Waste water outlet hose <math>\varnothing</math> 20 mm for siphon or external waste water tank; the hose may vary depending on the country.</p> <p>3 Power cable with plug or fixed connection with main switch; the plug may vary from country to country.</p> | <p>4 Interface cable for communication of the coffee machine with the optional accessories</p> <p>5 Mains water supply 3/8" or connection to the optional external drinking water tank</p> <p>6 USB port and communication interface</p> |
|--|--|

The serial plate provides information about the maximum required fuse and the minimum required cross-section.



See 2.3 "On-site mains connection"  
See 6.3 "Installation"

## 4.3 Operating elements

### 4.3.1 Machine operating elements



Figure: Overview of external operating elements

- |   |  |   |   |
|---|--|---|---|
| 1 | Manual inlet for ground coffee, cleaning tab   | 5 | Grounds container                       |
| 2 | Touch screen   | 6 | Cup positioning aid for one or two cups |
| 3 | User panel, can be pushed upwards  | 7 | Drip tray with drip grid                |
| 4 | Beverage outlet, manual up/down movement or optional automatic height adjustment (AHA) |   |   |

### 4.3.2 Machine operating elements

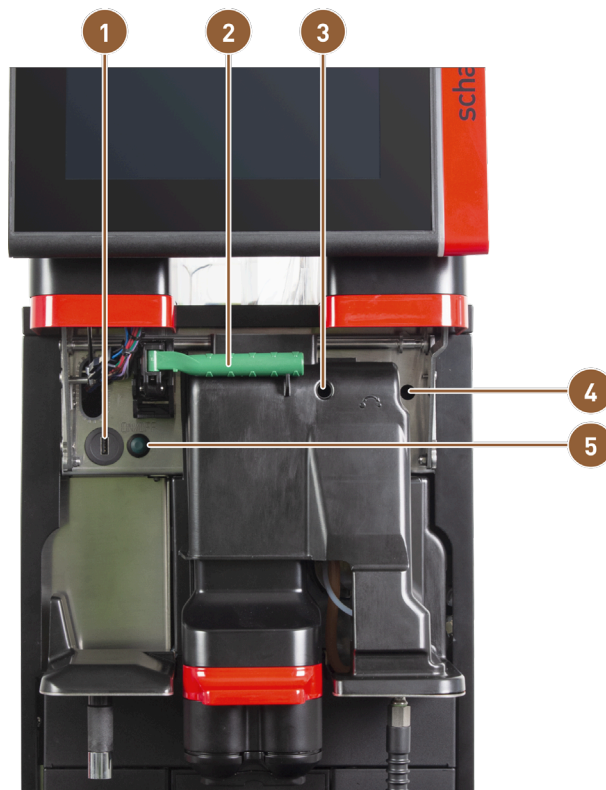

Figure: Machine operating elements

- |  |   |
|--|---|
| <ul style="list-style-type: none"> <li>1 USB connection</li> <li>2 Release lever for bean hoppers and powder containers</li> <li>3 Manual grinding level adjustment for centre grinder (standard equipment)</li> </ul> | <ul style="list-style-type: none"> <li>4 Manual grinding level adjustment for optionally available right grinder</li> <li>5 Machine ON/OFF button (press and hold for 4 s to switch off)</li> </ul> |
|--|---|

If the machine is equipped with the optional **automatic grinding level adjustment** function, the adjustment devices for manual grinding level adjustment are not available. In this case, the coffee machine automatically regulates the grinding level according to the brewing time of a reference beverage. The reference beverage is parametrised by the service technician.

### 4.3.3 Bean hoppers with integrated manual inlet



Bean hopper and powder container lids are available with a closing device as an option.

The centre bean hopper with integrated manual inlet comes as standard. The opening for the Coffeepure cleaning tab inlet is the same as the manual inlet.



Figure: Bean hoppers with integrated manual inlet

- 1 Centre bean hopper
- 2 Manual inlet for ground coffee (e.g. decaffeinated coffee)
- 3 Cleaning tab insert (Coffeepure tab)

#### 4.3.4 User interface



Figure: User interface: Overview

- 1 User interface for beverage selection in Self-service mode
- 2 User interface in Staff mode
- 3 User interface with selection via beverage groups
- 4 Navigation to the next or previous screen
- 5 Dispensing of hot water or steam
- 6 Beverage button with symbol or text only
- 7 Access to Service menu

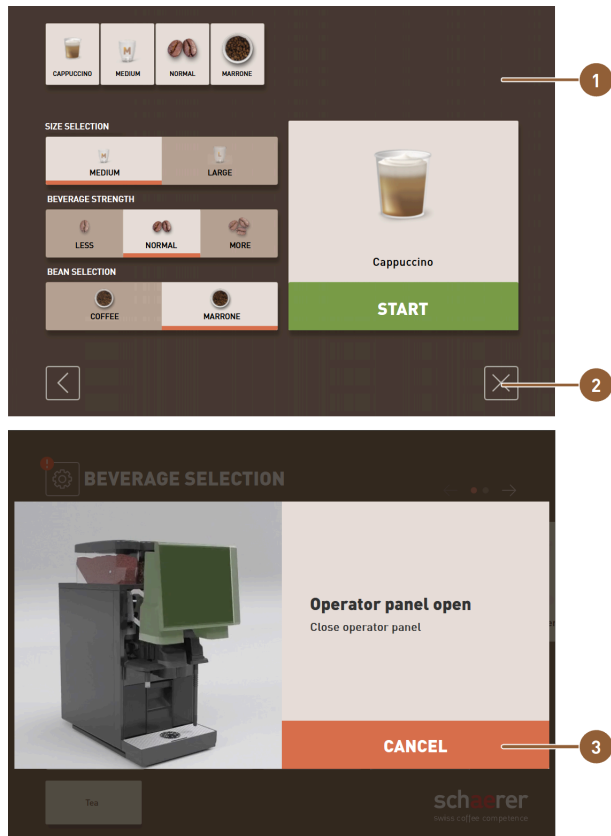

Figure: Overview: Operating functions on the interface

- 1 Beverage option selection
- 2 Button [X]: Back or cancel

- 3 Error messages or instructions for action

## 4.4 Equipment variants

### 4.4.1 Schaerer Coffee Soul with 10-inch display



Figure: Schaerer Coffee Soul with 10-inch display

The standard version of the Schaerer Coffee Soul with the 10-inch display is equipped with décor elements according to the configuration and a 10-inch touch screen.

Various options can be configured while ordering the machine.

#### 4.4.2 Schaerer Coffee Soul with 12-inch display



Figure: Schaerer Coffee Soul with 12-inch display

The standard version of the Schaerer Coffee Soul with the 12-inch display is equipped with chrome front elements, décor elements according to the configuration and a 12-inch touch screen.

Various options can be configured while ordering the machine.

### 4.4.3 Ambient light with function

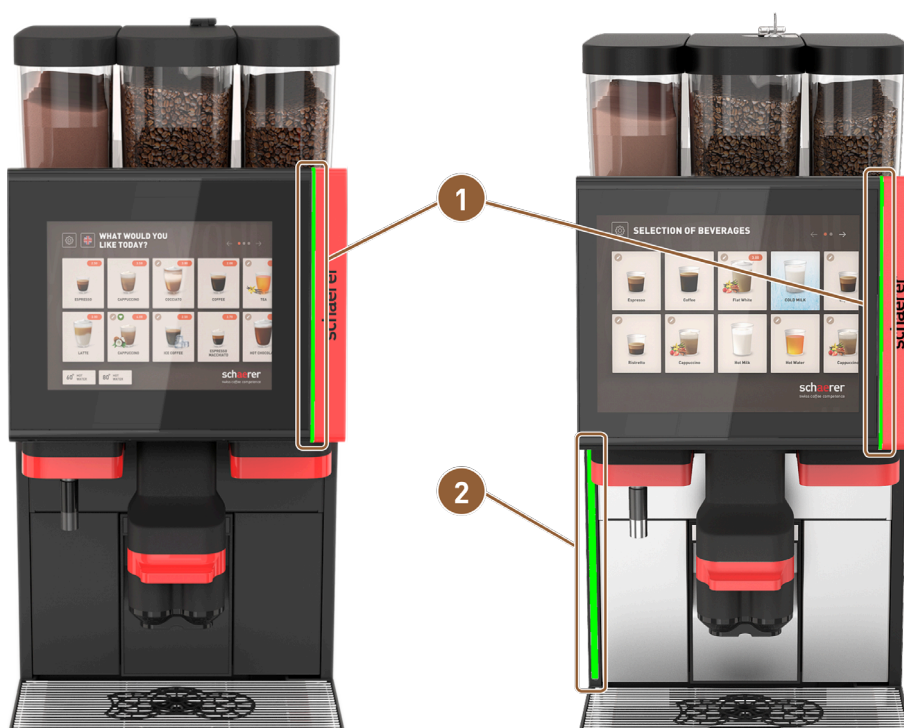

Figure: Ambient light with function

- 1 Lighting right of display (10" display and 12" display)      2 Lighting on left machine side (12" display only)

The ambient light to the right of the display **(1)** on both machine versions and on the entire left-hand side of the machine **(2)** on the SOUL with 12-inch display can be colour-coded and also provides information on the operating status of the machine.

#### 4.4.4 Automatic height-adjustable beverage outlet (AHA)



Figure: Automatically height-adjustable beverage outlet

With the **AHA** option, the optimum height of the beverage outlet is automatically adjusted to the selected beverage. The **AHA** option cannot be retrofitted.



#### 4.4.5 Drip tray with operating unit



The drip tray collects spilled beverages, drops and the cleaning water. The drip tray must be connected to a waste water hose during installation, which is either led into an external waste water tank or connected directly to the waste water connection.

The machine is equipped with an additional operating unit on the front that enables navigation on the screen.



Figure: Drip tray with operating unit

Button	Behaviour
	Navigates to the left in the menu.
	Navigates to the right in the menu.

Button	Behaviour
	Confirms the selection.
	Deletes the last input. Press and hold to return to the main menu.

#### 4.4.6 Steam wand



Figure: Steam wand

The machine can optionally be equipped with a steam wand. The steam wand function allows for separate manual milk heating and barista-style milk foaming.

The steam wand is mounted to the right of the beverage outlet.

The **steam wand** option cannot be retrofitted.

The following steam wand versions are possible:

Designation	Description
Powersteam	The steam outlet is started and stopped manually.
Autosteam	The steam outlet is started manually and stopped automatically by a temperature sensor when a programmable target temperature is reached.
Supersteam	The steam outlet is started manually and stopped automatically by a temperature sensor when a programmable target temperature is reached. In addition to the steam, air is blown in through an air pump.

#### 4.4.7 Hot water outlet



Figure: Hot water outlet

The separate hot water outlet enables manual dispensing to the left of the beverage outlet.

The **hot water outlet** option cannot be retrofitted.

#### 4.4.8 Additional water for preparing americanos



Figure: Additional water

In addition to dispensing coffee, hot water (additional water) can be dispensed into the cup through the beverage outlet.

This option suited to preparing **americanos**.

The sequence of coffee and additional water is defined in the beverage configuration.

The **additional water** option cannot be retrofitted.

#### 4.4.9 Brewing accelerator



Figure: Brewing accelerator

The **brewing accelerator** allows for more efficient dispensing of large beverages (e.g. americanos) with improved beverage quality. An additional quantity of hot water is guided into the coffee outlet after the brewing unit.

The **brewing accelerator** option cannot be retrofitted.

#### 4.4.10 Lockable bean hoppers



Figure: Lockable bean hoppers

Lockable bean hoppers can be supplied as an option. The bean hoppers can also be ordered with a closing device.

#### 4.4.11 Additional grinders



Figure: Equipment with second grinder and powder system

The machine can optionally be equipped with up to three grinders and three bean hoppers.

When equipped with two grinders, an additional bean hopper is available on the right. An optional powder container is always placed on the left-hand side. A second grinder can be used to process a second coffee bean type.

When equipped with three grinders, an additional bean hopper is installed on the left instead of the powder container.

The **second or third grinder** option cannot be retrofitted.

Bean hopper variants:

- Standard bean hopper 1200 g
- Extended bean hopper 2000 g
- Shortened bean hopper 700 g

#### 4.4.12 Powder system 2000 g (choco or topping)



Figure: Powder system

Choco and/or topping powder can be used with a **powder system** to the left of the standard centre grinder.

The **powder system** option cannot be retrofitted.

#### 4.4.13 Mixing cup for powder or topping system

The machine can optionally be equipped with a choco or topping powder system. A mixing cup is part of the equipment in this case.



Figure: Operating elements on mixing cup for powder or topping system (option)

- |                            |                               |
|----------------------------|-------------------------------|
| <b>A</b> Ventilation       | <b>C</b> Mixing cup           |
| <b>B</b> Water supply pipe | <b>D</b> Choco / Topping line |



When installing the mixing cup, make sure that the **(A)** ventilation connections, water supply **(B)**, mixing cup **(C)** and choco/topping line connections **(D)** are fitted correctly and pushed in as far as they will go.

The mixing cup must be removed from the machine upon instruction during the cleaning programme.



See 9 "Cleaning"

#### 4.4.14 Twin powder system



Figure: Twin powder system

The **Twin powder system** provides two powder types in one container.

The powder container for Twin Choco or Twin Topping is divided in the centre and has two compartments for different types of powder.

The **Twin powder system** option cannot be retrofitted.

#### 4.4.15 Décor elements



Figure: Décor elements

**Décor elements** can be used to adapt the machine to its surroundings.

Different colours are available.

The **Décor elements** option cannot be retrofitted.

#### 4.4.16 External waste water / drinking water tank monitored

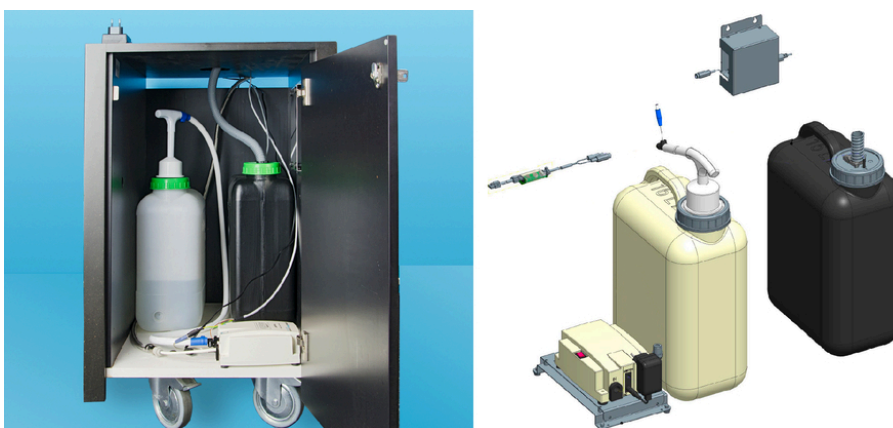

Figure: External waste water / drinking water tank

The machine can also be used in mobile applications thanks to the optional device with the external waste and drinking water tanks.

The fill level of both tanks is monitored.

The option can be retrofitted from software version v2.0.

#### 4.4.17 Under-counter grounds disposal

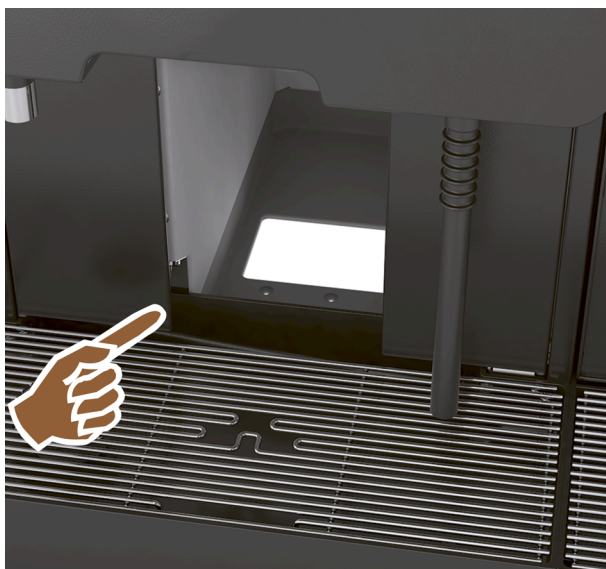

Figure: Under-counter grounds disposal

The grounds container and the machine base have an opening that continues into the counter. The coffee grounds are collected in a large container underneath the counter.

An **under-counter grounds disposal** unit increases the capacity for the ejected coffee cakes.

The **under-counter grounds disposal** option can be retrofitted.

#### 4.4.18 Machine feet



Figure: Machine feet

The machine feet increase the distance from the standing surface by 40/70/100 mm. In general, the machine feet are mandatory when using UC optional accessories.

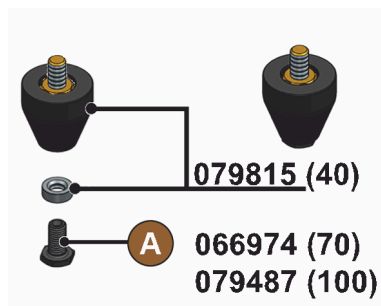

Figure: 40/70/100 mm foot (delivery without screw [A])

The **machine feet** option can be retrofitted.

#### 4.4.19 Cup positioning aid

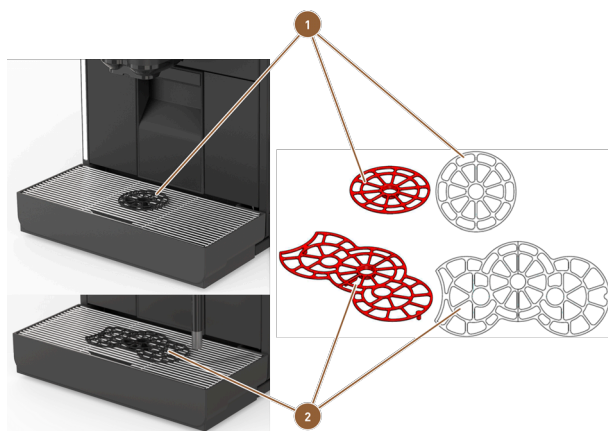

Figure: Cup positioning aid

① Single cup positioning aid

② Cup positioning aid for two cups

Various cup positioning aids for snapping into the cup platform for one or two cups or mugs are available as an option.

The two-cup positioning aid is supplied by default.

The **Cup positioning aid** option can be retrofitted.

#### 4.4.20 Best Foam™ (fresh milk system)



Figure: Best Foam™ (fresh milk system)

The **Best Foam™** function allows for integrated automatic milk heating and barista-style milk foaming.

It is possible to dispense cold milk and cold milk foam.

A cooling unit is mandatory with the **Best Foam™** function.

The **Best Foam™** option cannot be retrofitted.

#### 4.4.21 Hot & Cold (cold beverages)



Figure: Hot & Cold (cold beverages)

The **Hot & Cold** function allows for hot and cold beverages to be dispensed alternately.

The **Hot & Cold** option cannot be retrofitted.

#### 4.4.22 Schaerer Coffee Link (data exchange)



Figure: Schaerer Coffee Link

The **Schaerer Coffee Link** digital solution provides comprehensive information for quality assurance as well as for monitoring and optimising individual business processes.

Various types of data can be read from the machine via the Schaerer **Coffee Link** web portal.

The **Schaerer Coffee Link** option can be retrofitted.

#### 4.4.23 Payment systems



Figure: Payment systems

Commercially available **payment systems** in accordance with the MDB standard can be connected.

Possible interfaces:

- MDB-S
- DIVA 2
- DIVA2 Max

Connection to dispensing equipment and cash register systems:

- Via E protocol
- Via CSI protocol

Coin and token testers or coin changers can be placed to the right or left of the machine.

The **payment systems** option can be retrofitted.

#### 4.4.24 Flavour Point

The machine is optionally equipped with the **Flavour Point** syrup module. This allows various syrup ingredients to be used to flavour beverages.



Figure: Flavour Point

The device is placed directly under the machine as an under-counter solution.

The **Flavour Point** option cannot be retrofitted.

#### 4.4.25 Operating elements on the Flavour Point



Figure: Operating elements on the Flavour Point

- 1** Connection for four adapters for syrup bottles or four hoses from the cleaning set
- 2** On/Off press switch

#### 4.4.26 SOUL with side cooling unit

The machine can be operated with a side or under-machine cooling unit.



Figure: Right/Left side cooling unit

The machine is supplied with a *right* machine connection as standard.

The *right* side cooling unit does not require additional adjustments. The cooling unit features a 10 l milk container and its own removable drip tray with drip grid.

Placing the side cooling unit on the *left* requires additional adjustment of the milk hose guide in the machine.



#### ADVICE

##### Conversion of machine

Placing the cooling unit anywhere other than to the right of the machine requires conversion work. The description of how to perform this conversion work as well as the components required are delivered with the side cooling unit.

### 4.4.27 Side cooling unit for Centre Milk (CM)



Figure: Side cooling unit for Centre Milk (CM)

The side cooling unit can also be positioned between two machines, thereby supporting the Centre Milk function.

The side cooling unit with Centre Milk equipment provides a simultaneous milk supply for two machines.



#### ADVICE

##### Conversion of machine

Placing the cooling unit anywhere other than to the right of the machine requires conversion work. The description of how to perform this conversion work as well as the components required are delivered with the side cooling unit.

#### 4.4.28 Under-machine cooling unit



Figure: Under-machine cooling unit

The under-machine cooling unit can be placed directly beneath the machine. The cooling unit features a 9.5 l milk container.

The machine is delivered with a milk connection at the right by default.



#### ADVICE

##### Conversion of machine

Placing the cooling unit anywhere other than to the right of the machine requires conversion work. The description of how to perform this conversion work as well as the components required are delivered with the side cooling unit.

#### 4.4.29 Under-counter cooling unit (UC)



Figure: Under-counter cooling unit (UC)

The under-counter cooling unit is placed in the counter under the machine.

The under-counter cooling unit with Centre Milk equipment can simultaneously supply two machines with milk.



#### ADVICE

##### Conversion of machine

Placing the cooling unit anywhere other than to the right of the machine requires conversion work. The description of how to perform this conversion work as well as the components required are delivered with the side cooling unit.

### 4.4.30 Cooling unit operating elements



Figure: Side cooling unit thermostat/operating elements

**A** Cooling unit operating elements

**B** Cooling unit on/off toggle switch

### 4.4.31 Cup warmer

The machine can also be operated with a cup warmer as an optional accessory.



Figure: Cup warmer

The cup warmer optional accessory can be placed to the left or right of the machine and is available in narrow and wide versions.

The narrow cup warmer has room for approx. 60 – 264 coffee cups. The wide version has room for 88 – 320 coffee cups.

#### 4.4.32 Cup & Cool

The machine can optionally be operated with the **Cup & Cool** optional accessory.



Figure: Cup & Cool

The **Cup & Cool** optional accessory is available in the *narrow* and *wide* variants.

The narrow variant is placed to the *left* of the machine.

The *wide* variant can also be placed between two machines in the Centre Milk version.

**ADVICE****Conversion of machine**

Placing the **Cup & Cool** anywhere other than to the left of the machine requires conversion work. The description of how to perform this conversion work as well as the components required are delivered with the side cooling unit.

**4.4.33 Cup & Cool, cup warmer operating elements**

Figure: Cup & Cool, cup warmer operating elements

- 1 Cooling unit on/off toggle switch
- 2 Cup warmer on/off toggle switch
- 3 Thermostat setting

#### 4.4.34 ProCare overview

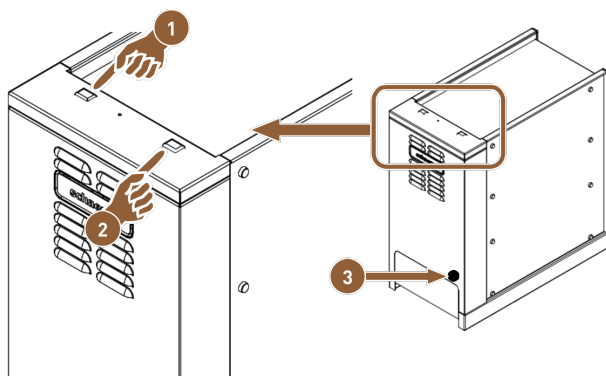

Figure: External overview

- |   |                            |   |                          |
|---|----------------------------|---|--------------------------|
| 1 | Cam lock                   | 4 | CAN bus connection cable |
| 2 | Hose adapter               | 5 | Power cable              |
| 3 | Connections for Plug&Clean |   |                          |

The Plug&Clean connections **(2)** are used for complete hose cleaning. The two milk hoses **(3)** are connected here and cleaned when Plug&Clean cleaning is selected.

The hose adapters **(3)** are the connecting piece between the milk hose and the suction pipe. The intake tube is inserted into the milk cooking box.

The ProCare unit is connected to the mains power supply with the power cable **(5)**.

The CAN bus connection cables **(4)** makes it possible to exchange data and commands between the machine and the optional accessories.

The cam lock **(1)** locks the drawer when closed, preventing unauthorised access.

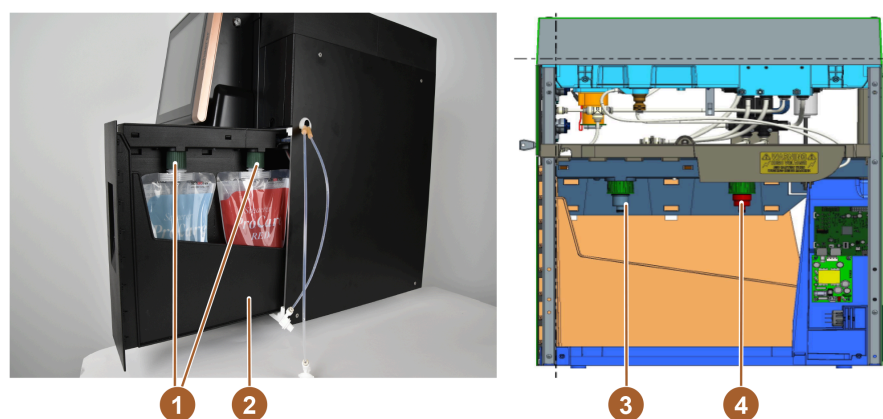

Figure: Internal overview

- |   |                 |   |  |
|---|-----------------|---|--|
| ① | Cap nut         | ③ | Coupling for ProCare cleaning bag blue |
| ② | Collecting tray | ④ | Coupling for ProCare cleaning bag red  |

The cap nut **(1)** secures the connection of the ProCare cleaning bags to the coupling and the drawer housing.

Both ProCare cleaning bags **(2)** are located in the collecting tray. The collecting tray also functions as a collecting tank in the lower area. If liquid unintentionally escapes from the cleaning bags, it is collected. The sensor issues an error message at the same time.

The ProCare cleaning bag blue is placed over the coupling nozzle **(3)** and tightened with the cap nut. The coupling is monitored by a sensor.

The ProCare cleaning bag red is placed over the coupling nozzle **(4)** and tightened with the cap nut. The coupling is monitored by a sensor.



#### ADVICE

#### ProCare cleaning system

Detailed information on this topic can be found in the **ProCare** operating instructions.

## 5 Transport

### 5.1 Scope of delivery and accessories

Quantity	Designation	Article number
Documentation		
1	Operating instructions (OI)	**
1*	Supplementary instructions of optional accessories (cup warmer + Cup & Cool)	**
1*	Side cooling unit operating instructions	**
Cleaning/Maintenance scope of delivery		
1*	Milkpure powder & Coffeepure tabs delivery set	075350
1*	Coffeepure tabs (equipment without milk)	065221
1	Brush 75-40 (brewing chamber)	067409
1	Cleaning brush (beverage outlet)	062951
Machine scope of delivery		
1*	Drip tray short cpl. SOUL	060387
General scope of delivery		
1	Measuring spoon	067111
Powder system*		
	Powder container outlet restrictor	079940
Descaling accessories***		
1	Decalcification cartridge****	079293

\* Optional, depending on machine model

\*\* Language-specific article number

\*\*\* Not contained in the scope of delivery

\*\*\*\* Omitted when using ProCare

### 5.2 Transport conditions



#### CAUTION

#### Risk of injury during transport!

Improper transport of the machine can lead to injuries.

- Observe the general regulations for health and safety in accordance with the local provisions.

**ADVICE****Material damage due to improper transport!**

Improper transport during relocation of the machine can damage it.

- ▶ Use a trolley to transport the machine.
  - ▶ Secure the machine on the trolley and pull the trolley.
- 
- ▶ Disconnect the following before relocating the machine:
    - Drinking water supply
    - Power supply
    - Waste water outlet
  - ▶ Make sure that the new location has no obstacles or uneven spots.

## 6 Installation and commissioning

### 6.1 Unpacking



#### CAUTION

#### Cutting and eye injury due to packaging material!



Packaging materials with sharp edges can cause injuries. Cutting straps can cause eye injuries.  
▶ Wear gloves and safety goggles when unpacking.



#### 6.1.1 Unpacking machine

1. Unpack the machine.
2. Remove the supplied accessories from the accessory box.
3. Check the remaining contents of the packaging for supplied accessories.
4. Check the delivery for completeness.
5. Keep the original packaging for possible return.

#### 6.1.2 Unpacking accessories

The following accessories are delivered:



Figure: Accessories included in delivery

- |   |  |   |   |
|---|--|---|---|
| 1 | Operating instructions and declaration of conformity | 6 | Milk hose guide to the left               |
| 2 | Brush for cleaning inside of grounds container       | 7 | Single cup positioning aid                |
| 3 | Spoon for ground coffee for manual inlet             | 8 | Drip tray with assembled waste water hose |
| 4 | Cup positioning aid for two cups                     | 9 | Small cleaning brush                      |
| 5 | Cleaning product (according to machine equipment)    |   |   |

## 6.2 Setup

### 6.2.1 Installation conditions

The location where the machine is set up must meet the following conditions:

- The installation surface must be stable, horizontal and level so that it does not become deformed under the weight of the machine.
- The machine must not be set up on hot surfaces or near heat sources.
- The machine must be set up in such a way that it can be supervised by trained staff at all times.
- The required supply connections must be led up to 100 cm (39.4") to the machine location in accordance with the manufacturer-side installation plans.
- The locally applicable kitchen regulations must be observed.
- Clearances for maintenance work and operation must be maintained:
  - Enough space must be left at the top for filling the coffee beans or powder; 20 cm (7.87") is recommended.
  - A distance of at least 5 cm (1.97") must be left from the rear of the machine to the wall to allow for sufficient air circulation.

### 6.2.2 Climatic conditions

The following climatic conditions apply to the location of the machine:

- Ambient temperature of +10 °C to +40 °C (+50 °F to +104 °F)
- Relative humidity of max. 80 % RH
- Maximum height above sea level of 2500 m (8202 ft)
- The machine is designed exclusively for indoor use. It must not be used outdoors and must never be exposed to weather conditions (rain, snow, frost).

## 6.3 Installation

The machine must be installed in accordance with the applicable national and local electrical and plumbing regulations. This includes an adequate non-return mechanism.



See 6.2.1 "Installation conditions"

See 6.3.1 "Connecting power supply"

The following connections are required at the installation site:

- Socket for mains plug or fixed connection with main switch
  - The serial plate provides information about the maximum required fuse.
  - The serial plate provides information about the minimum required fuse.
- Mains water supply 3/8" or connection to the external drinking water tank
- Siphon or external waste water tank for waste water hose Ø 20 mm
- Optional interface for communication of the machine with the optional accessories

All machine-side connections are ready for use at the time of delivery.

1. For better accessibility, position the rear of the machine approx. 5 cm (2") above the support plate.
2. Prepare the connections on the installation side.

### 6.3.1 Connecting power supply



#### DANGER

##### Risk of death due to electrocution!

There is a risk to life due to electrocution when connecting the machine.

- ▶ Make sure that the phase is fused with the ampere value specified on the serial plate.
- ▶ Make sure that all poles of the device can be disconnected from the mains power supply.
- ▶ Make sure that the manufacturer-side electrical system is designed in accordance with IEC 364 (DIN VDE 0100). To increase safety, a ground fault circuit interrupter with a nominal residual current of 30 mA (EN 61008) should be connected upstream of the device. Type B ground fault circuit interrupters ensure response even with smooth DC residual currents. This ensures a high level of safety.
- ▶ Never operate a device with a defective connection cable. Have a defective connection cable or plug replaced immediately by a qualified service technician.
- ▶ Schaefer AG does not recommend using an extension cord. If an extension cord is used in spite of this (minimum cross-section: 1.5 mm<sup>2</sup>), observe the manufacturer data for the cable (operating instructions) and comply with the locally applicable regulations.
- ▶ Route the connection cable in such a way that it does not pose a tripping hazard. Do not pull the cables over corners or sharp edges, pinch them between objects or allow them to hang loosely in a room. Do not place cables on hot objects and protect them from oil and aggressive cleaning products.
- ▶ Never lift or pull the device by the connection cable. Never pull the plug out of the socket by its connection cable.
- ▶ Never touch the cable or plug with wet hands. Never insert a wet plug into a power socket.



#### DANGER

##### Danger to life due to defective or non-original connection cable!

Use of a faulty connection cable or one that is not the original cable results in the risk of electric shock and fire.

- ▶ Only use original connection cables. The original connection cable for your country can be obtained from your service partner.
- ▶ Connection cables that are plugged in on both sides can be replaced by the customer.
- ▶ Have connection cables with a fixed connection replaced by a service technician.

The equipment must be connected in accordance with the regulations of the country in which it is installed. The voltage specified on the serial plate must match the mains voltage at the installation location. The mains socket and mains switch must be accessible to the operator at the installation site.

- ▶ Establish the mains connection.



See 4 "Product description"

See 2 "Technical data"

## 6.3.2 Connecting water supply



### CAUTION

#### Health problems due to improper handling of water!

Improper handling of water can cause health problems.

The following points must be observed without fail:

- ▶ The water must be free of dirt and bacteria.
- ▶ Do not connect the machine to pure reverse osmosis water or other aggressive types of water.
- ▶ The carbonate hardness must not exceed 4 – 6 °dKH (German carbonate hardness) or 8 – 12 °fKH (French carbonate hardness).
- ▶ The total hardness must always be higher than the carbonate hardness.
- ▶ The minimum carbonate hardness is 4 °dKH or 8 °fKH.
- ▶ The maximum chlorine content must not exceed the local regulations on the maximum permitted chlorine content.
- ▶ The pH value must be between 6.5 and 7 (pH neutral).

For machines with drinking water tank (internal and external):

- ▶ Fill the drinking water tank with fresh water daily.
- ▶ Rinse the drinking water tank thoroughly before filling.



### CAUTION

#### Health problems due to improper handling of coffee!

Improper handling of coffee can cause health problems.

The following points must be observed without fail:

- ▶ Check the packaging for damage before opening.
- ▶ Do not add more coffee beans than will be needed for one day.
- ▶ Close the bean hopper lid immediately after filling.
- ▶ Store coffee in a cool, dry, dark place.
- ▶ Store coffee separately from cleaning products.
- ▶ Use the oldest products first ("first in – first out").
- ▶ Always close opened packages tightly so that the contents remain fresh and are protected from contamination.



### ADVICE

#### Property damage due to poor water quality!

The machine can suffer damage due to bad material and incorrect water values.

Check the recommended water quality and optimise it if necessary.

The measures described for preventing this danger must be strictly observed:

- ▶ The water must be free of dirt and the chlorine content must not exceed the local regulations on the maximum permitted chlorine content.
- ▶ Do not connect the machine to pure osmosis or other aggressive types of water.
- ▶ The carbonate hardness must not exceed 4 – 6 °dKH (German carbonate hardness) or 8 – 12 °fKH (French carbonate hardness) and the value of the total hardness must always be higher than the carbonate hardness.
- ▶ The minimum carbonate hardness is 4 °dKH or 8 °fKH.
- ▶ The pH value must be between 6.5 and 7.
- ▶ Always use the new hose set supplied with the machine (fresh/waste water hose).

The machine must be connected to the water supply in accordance with applicable requirements and the regulations of the respective country. If the machine is connected to a newly installed water line, the line and intake hose must be rinsed thoroughly to ensure that no dirt gets into the machine.

The machine must be connected to an installed drinking water line with a shut-off valve. Installation is done using the assembled pressure hose and the G 3/8" screw connection to the pressure reducer attached to the tap. The pressure reducer must be set to 0.3 MPa (43.5 psi).

The machine requires an waste water outlet. The supplied temperature-stable waste water hose is connected to a siphon at the installation site. The waste water hose should create a downward slope to the connection to prevent the siphon effect.

The machine with an external drinking or waste water tank is connected directly. Corresponding level monitoring is available.



The **Supplementary Instructions for Water Quality – N° 022960** contain information on recording water values and the use of filter techniques. The supplementary instructions can be requested from Schaerer AG or downloaded directly from the website ([www.schaerer.com/member](http://www.schaerer.com/member)) from the Media Pool.

### External drinking and waste water tank variant

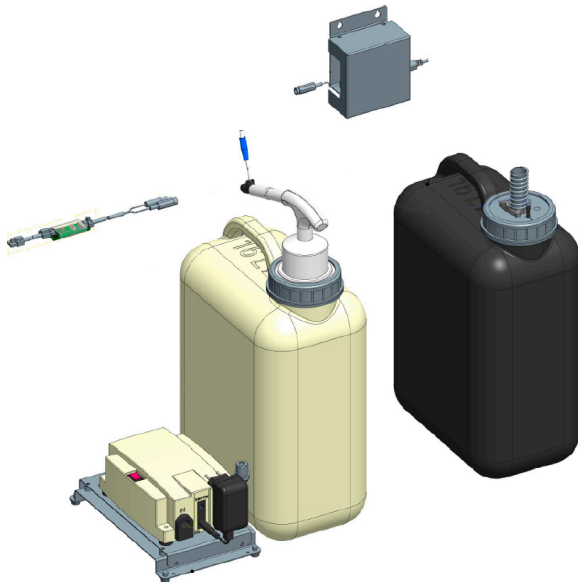

Figure: External drinking and waste water tank

The machine can optionally be operated with a monitored external drinking and waste water tank.

- ▶ Connect the drinking and waste water connections of the machine directly to the water tanks.



The conversion instructions for the **monitored drinking and waste water tank for the SOUL** contain information on setting up and connecting the external drinking and waste water tanks. The conversion instructions can be requested from Schaerer AG or downloaded directly from the **Media Pool** on the website ([www.schaerer.com/member](http://www.schaerer.com/member)).

### 6.3.3 Assembling drip tray



Figure: Assembling drip tray

- |   |  |   |                      |
|---|--|---|----------------------|
| 1 | Front flap left                          | 4 | Mounting screws (2x) |
| 2 | Device base insert for grounds container | 5 | Drip tray            |
| 3 | Front flap right                         |   |                      |

1. Open the two front flaps **(1)** and **(3)**.
  - ✓ The holes for the mounting screws **(4)** are visible.
2. Guide the waste water hose on the drip tray backwards through the machine.
3. Position the drip tray **(5)** and press it onto the machine. At the same time, lift the device base insert for the grounds container **(2)** slightly.
4. Secure the drip tray with the two mounting screws **(4)**.
  - ✓ The drip tray is mounted.

### 6.3.4 Connecting ProCare unit

Prerequisite: The machine must be switched off to connect the ProCare unit.

#### Overview of installation steps

1. Connect the ProCare unit to the machine.
2. Connect the ProCare unit to the cooling unit.
3. Connect the milk hoses.
4. Connect a **CAN bus** connection cable to the machine.
5. Connect the other **CAN bus** control cable to the optional accessory (e.g. milk system).
6. Connect the mains plug to the mains power supply.
  - ✓ The module is switched on.
7. Switch on the machine.
  - ✓ The modules connects to the machine.
8. Start the machine commissioning routine.



More information on retrofitting a coffee machine with the ProCare unit or the side cooling unit with the ProCare unit can be found in the separate ProCare installation instructions.

### 6.3.4.1 Connecting ProCare unit to machine

The following requirements must be fulfilled for a machine with ProCare preparation:

- The metal bracket for holding the ProCare unit is installed in the machine.
- The side panel of the machine already has the hole for the ProCare unit mounting screw.
- The hoses for connecting to the ProCare unit are routed out of the side of the machine and fastened with cable ties.

#### Connecting ProCare unit



Figure: Fastening ProCare unit to machine

- |   |                       |   |                |
|---|-----------------------|---|----------------|
| 1 | Connecting plate      | 3 | Mounting screw |
| 2 | Hoses to ProCare unit |   |                |

1. Snap the ProCare unit into the connecting plate **(1)** on the machine.
2. Insert the Teflon hoses **(2)** into the ProCare unit.
3. Screw the ProCare unit onto the machine **(3)**.

#### Connecting hoses

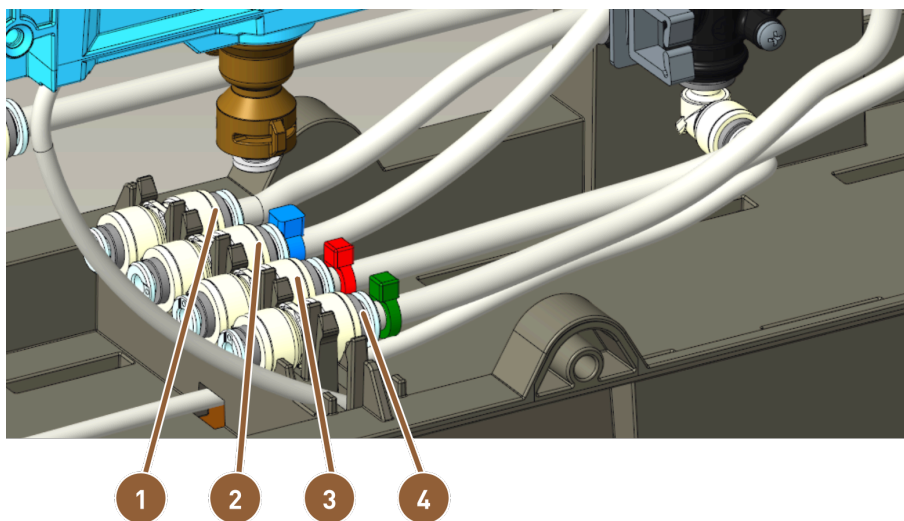

Figure: Assignment of hose connections

- |   |             |   |                |
|---|-------------|---|----------------|
| 1 | White: Milk | 3 | Red: Descaling |
| 2 | Blue: Water | 4 | Green: Coffee  |

1. Cut the hoses to length so that they can be arranged in a loop.
2. Arrange the hoses in a loop in case you ever need to remove the module.
3. Connect the hoses according to the label.
4. Make sure that the hoses do not block the closing mechanism of the front panel.

#### 6.3.4.2 Connecting ProCare unit to cooling unit

##### Assembling cooling unit

1. Assemble the metal bracket on the side of the ProCare unit where the cooling unit is attached.
2. Close the ProCare unit with the supplied side panel depending on the positioning of the right housing or the left housing.
3. Attach the cooling unit to the ProCare unit.

##### Adjusting milk hose

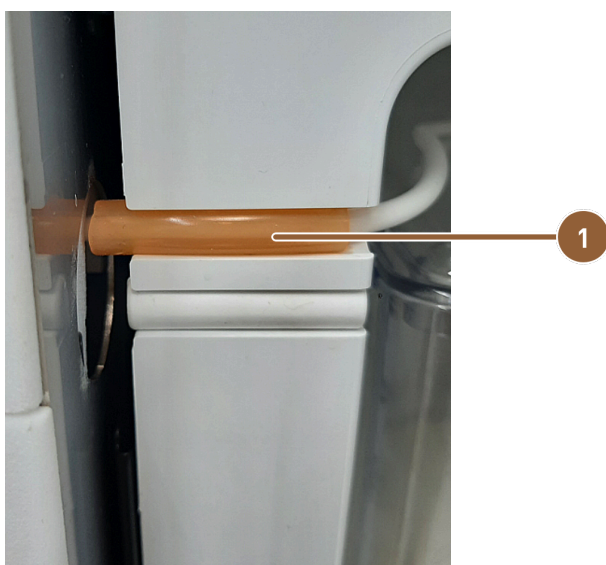

Figure: Milk hose in cooling unit

##### 1 Orange marking hose

1. Install the milk hose and cut it so it reaches the Plug & Clean connection on the ProCare unit.
2. Cover the milk hose with the orange 4/8 silicone hose **(1)** and use it to clamp the hose into the recess of the refrigerator.

#### 6.3.4.3 Connecting ProCare unit cable

Connect the power cable and CAN bus before switching on the device.

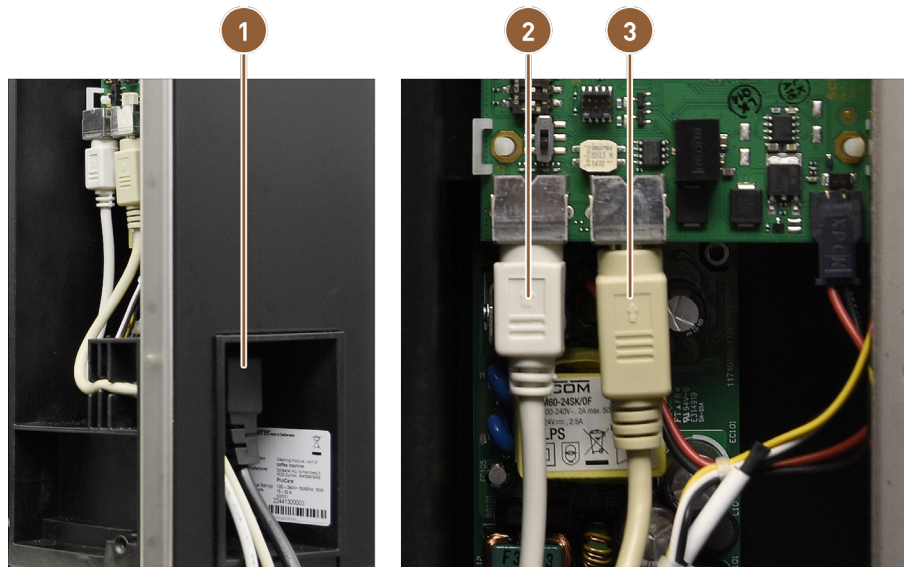

Figure: ProCare cable connections

- 1 Mains connection with cold device plug
- 2 Can bus cable from machine
- 3 Can bus cable from cooling unit

1. Connect the cold device plug to the connection on the back of the ProCare unit **(1)**.
2. Connect the 2 m CAN mini DIN 6-pole control cable **(2)** to the ProCare unit.
3. Connect the CAN bus cable of the refrigerator **(3)**.

### 6.3.5 Connecting milk system

The optional milk hose is removed from the squeeze valve during transport. Before commissioning, the milk hose must be correctly reinserted into the squeeze valve, see figure below.



#### ADVICE

##### Twin Milk option

Machine equipment options with **Twin Milk** contain two squeeze valves and two milk hoses.

1. Lift the user panel.



See 8.1.6 "Opening and closing user panel"

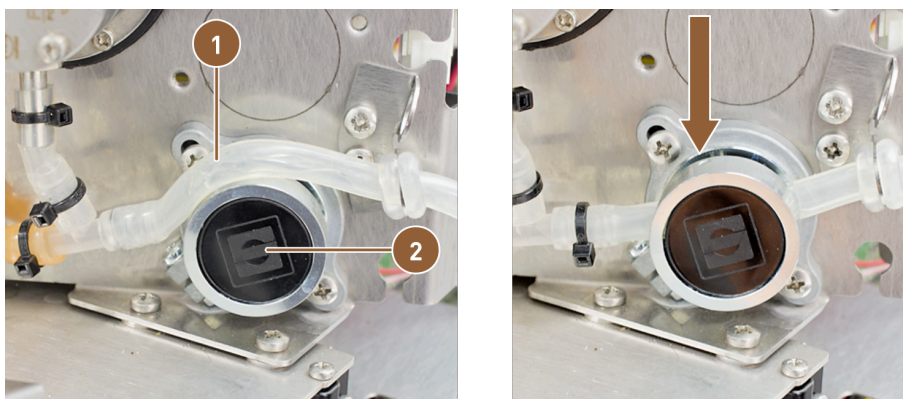

Figure: Inserting milk hose into squeeze valve (Single Milk)

1 Milk hose

2 Squeeze valve

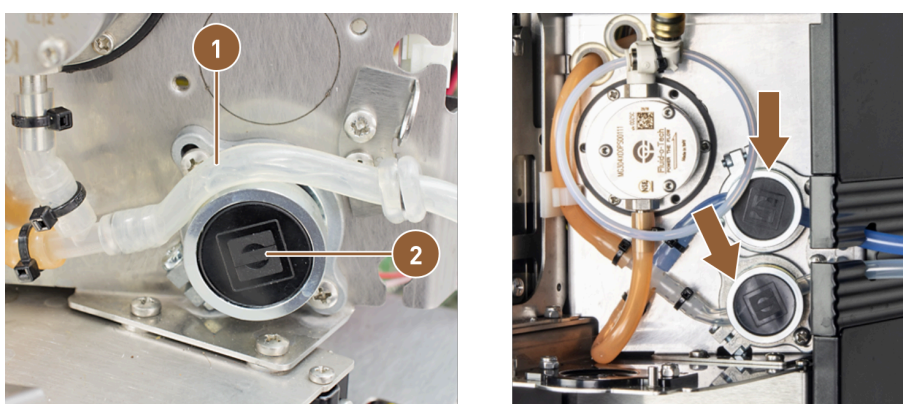

Figure: Inserting milk hoses into squeeze valves (Twin Milk)

1 Milk hose

2 Squeeze valve

2. Pull the black cover on the right forwards without tools.
  - ✓ The milk pump and the squeeze valve **(2)** are accessible.
3. For Single Milk systems: Insert the milk hose **(1)** into the squeeze valve **(2)** as shown.
4. For Twin Milk systems: Insert the two milk hoses into the two squeeze valves.

## 6.4 Installing optional accessories



All optional accessories with an integrated cooling unit or with feed pumps require a communication connection (CAN bus) to the machine. The connections are always serial.

### 6.4.1 Connecting optional accessories to power supply

All optional accessories require a mains connection 230 V / 50 Hz. The mains connection is established via an assembled and tested connection cable that is supplied with the optional accessories.

## 6.4.2 Establishing communication connection (CAN bus)

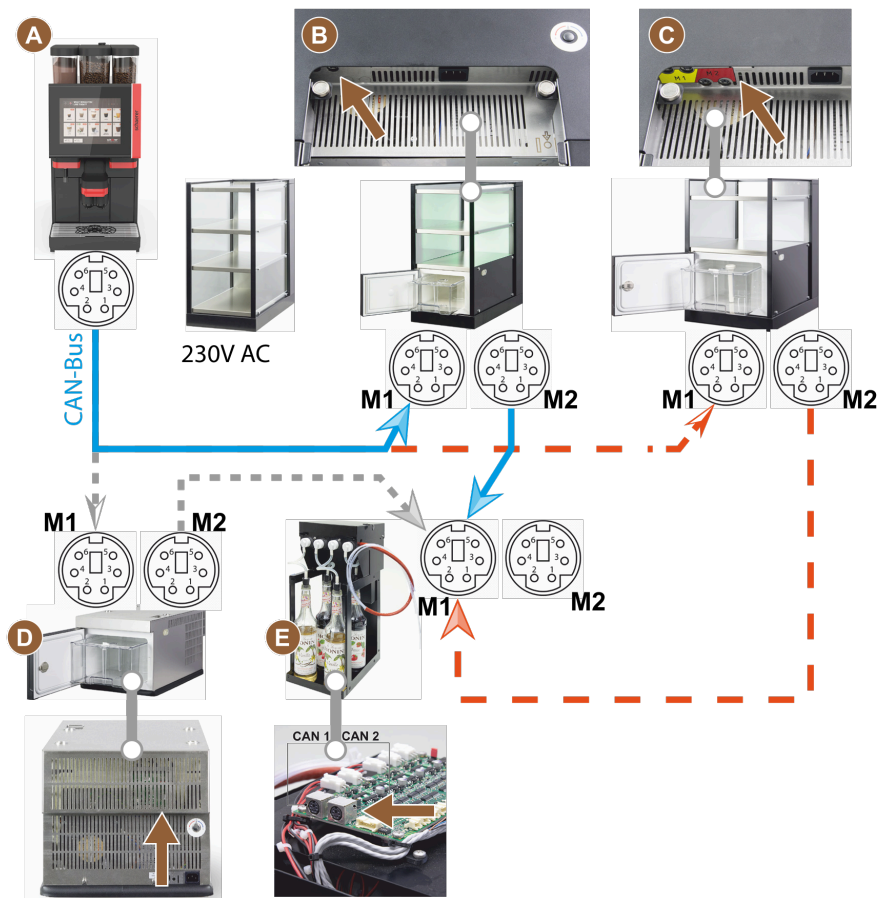

Figure: CAN bus connections from the machine to optional accessories (example display)

- |   |  |                                     |
|---|--|-------------------------------------|
| <b>A</b> Machine to ...                   | <b>(B)</b> or <b>(C)</b> or <b>(D)</b> and to <b>(E)</b> | <b>D</b> Under-machine cooling unit |
| <b>B</b> Cup & Cool narrow/wide           |  | <b>E</b> Flavour Point (syrup UC)   |
| <b>C</b> Cup & Cool thin/wide Centre Milk |  |                                     |

1. Establish the CAN bus connection using a control cable with a 6-pole DIN plug. To do this, connect the control cable to the communication interface of the machine.
2. Connect the other end of the control cable to the desired optional accessory.
3. If necessary, use another control cable with a 6-pole DIN plug to establish the connection from one optional accessory to another optional accessory.

## 6.4.3 Connecting 4-fold Flavour Point UC (syrup module) (option)



The **Flavour Point 4-way UC** optional accessory cannot be retrofitted.  
For correct hose laying, machine feet of at least 40 mm in height must be fitted to the machine.

### Flavour Point hose connections

Prerequisite:

- The machine was prepared for the **Flavour Point** option at the factory.
- The necessary hose connections are led out of the right-hand side of the machine.

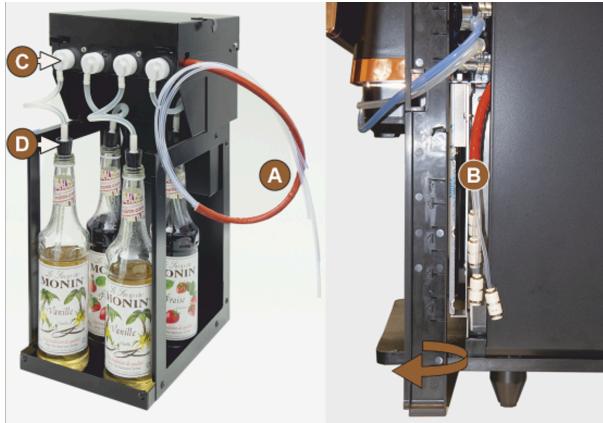

Figure: Flavour Point SOUL hose connection

1. Lift the bean hoppers and powder containers out of the machine.
2. Loosen the four screws from the machine cover.
3. Lift the cover slightly on the right-hand side.
4. Slide the narrow housing strip on the right upwards and unlock it.
  - ✓ The plug-in connections led out of the machine are now accessible on the right side of the machine **(B)**.
5. Plug the connection hoses from the Flavour Point **(A)** into the prepared plug-in connections in an offset position.
6. Refit the side housings on the right and the machine cover.
7. Replace the bean hoppers and powder containers.
  - ✓ The hose connection from the Flavour Point to the machine has been installed.

### Syrup type labels

The customer can label the device at the installation site using self-adhesive labelling strips.

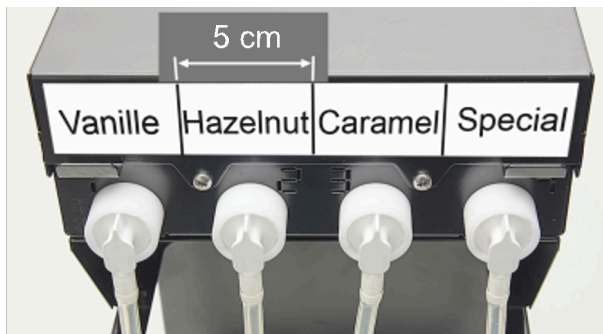

Figure: Labelling example for hose connections from syrup bottle to syrup pump

1. Divide the labelling strips into 4 fields (4 pumps) of approx. 5 cm (2").
2. Label the syrup pumps according to the type of syrup bottles connected.
  - ✓ The hose connection from the syrup bottle to the syrup pump is labelled.
  - ✓ After cleaning, assignment under the syrup types is clearly visible.

## 6.5 Display-guided commissioning



The commissioning programme automatically starts the first time the machine is switched on. It explains all aspects of installation. Service technicians can start the commissioning programme manually at any time.



See 8.2 "Switching on"

## 7 Setup and adjustment

### 7.1 Converting milk system to the left

#### 7.1.1 Required components and tools



Figure: Accessories included in delivery

① Plastic hose guide

- Plastic hose guide 079880 **(1)**
- Cross slot screwdriver PH1

#### 7.1.2 Required conversion steps

- Preparation for conversion
- Convert side strip openings
- Lay milk hoses in the machine to the left
- Assemble right housing and left hose guide
- Guide milk hose out to the left

#### 7.1.3 Preparation

1. Remove the bean hoppers and powder containers.
2. Remove the right, left and top housing.
3. Move the user panel to the top position.
4. Remove the squeeze valve cover **(B)**. This can be done without tools.

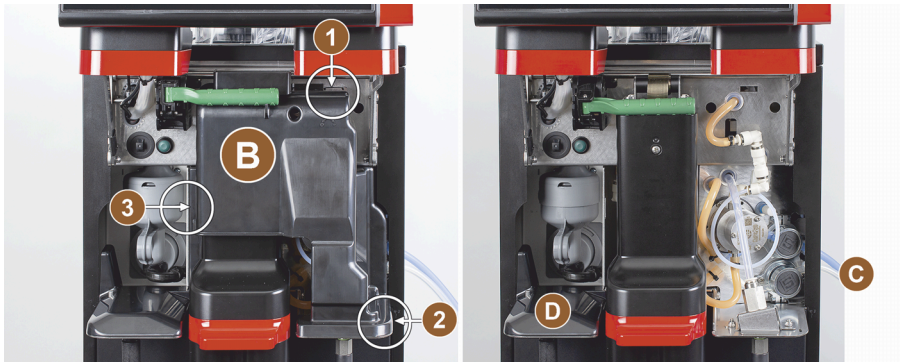

Figure: Removing squeeze valve cover

- |          |                     |          |   |
|----------|---------------------|----------|---|
| <b>B</b> | Squeeze valve cover | <b>1</b> | Snap-in position of squeeze valve cover |
| <b>C</b> | Conversion position | <b>2</b> | Snap-in position of squeeze valve cover |
| <b>D</b> | Cover               | <b>3</b> | Snap-in position of squeeze valve cover |

5. Remove the squeeze valve cover **(B)** behind the user panel by releasing the cover at positions **(1)**, **(2)** and **(3)**.
6. Lift the cover **(D)** and remove it as well.
  - ✓ The machine is ready for conversion **(C)**.

### 7.1.4 Converting side strip openings

Prerequisite:

- The side housings have been removed.
- The squeeze valve cover has been removed.



#### ADVICE

#### Twin Milk option

Machine equipment options with **Twin Milk** contain two squeeze valves and two milk hoses.

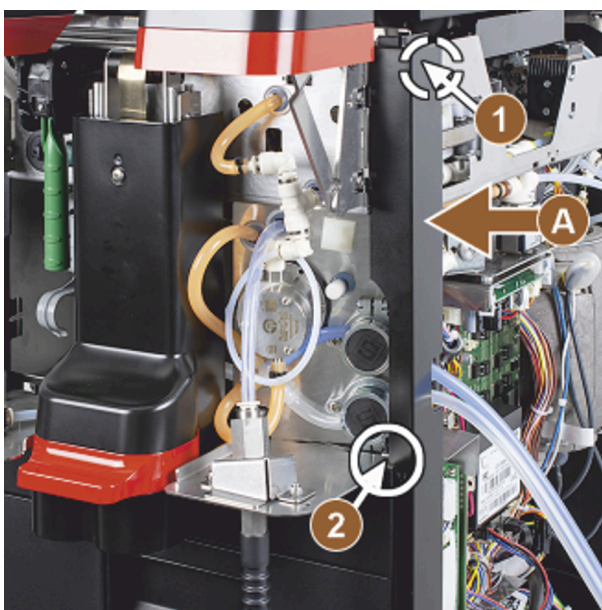

Figure: Side strip fastening

1. Slide the right and left side strips **(A)** upwards and remove them from the fixings **(1)** and **(2)**.  
✓ Both side strips are disassembled.

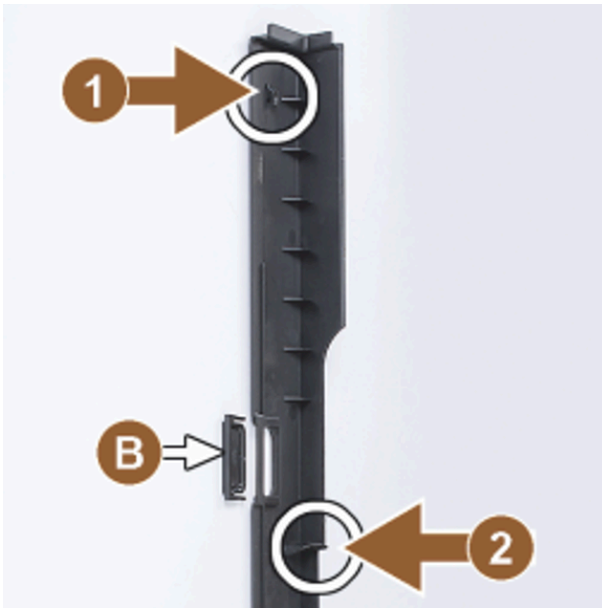

Figure: Side strip, dummy cover

2. Remove the milk hoses from the right side strip.
3. Remove the dummy cover **(B)** from the left side strip and slide it into the right strip.  
✓ Both side strips are now ready for reassembly.

### 7.1.5 Laying milk hoses in the machine to the left

Prerequisite:

- The milk hoses are not in the guide **(C)**.
- The openings of the side strips are converted.

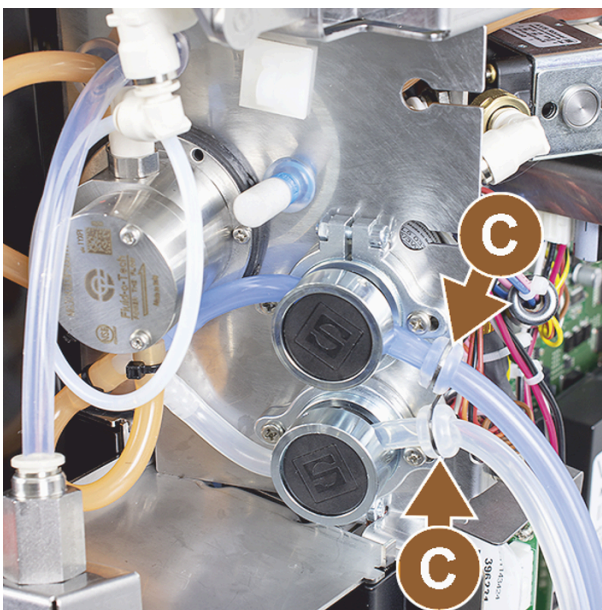

Figure: Milk hose guides

1. Remove the milk hoses from the guides **(C)**.
2. Place the milk hoses to the rear.
  - ✓ The milk hoses can be guided to the rear.

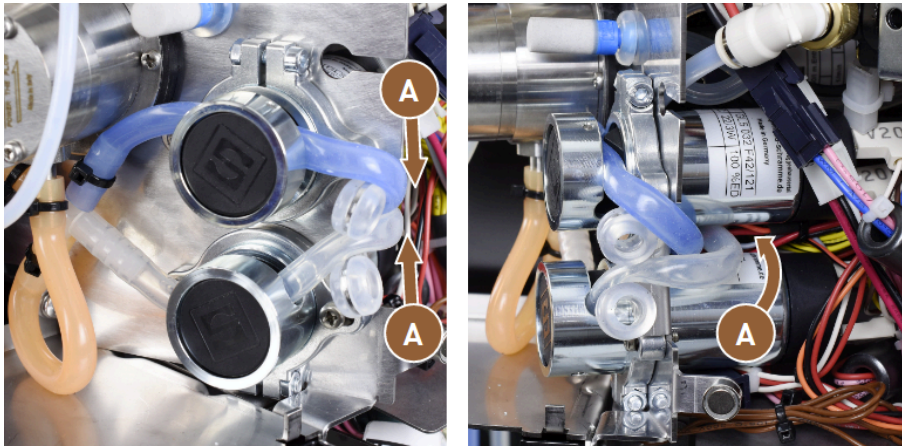

Figure: Laying milk hoses

3. Guide the milk hoses to the rear as shown in the figures **(A)**.
4. Guide the milk hoses behind the beverage outlet to the left side.

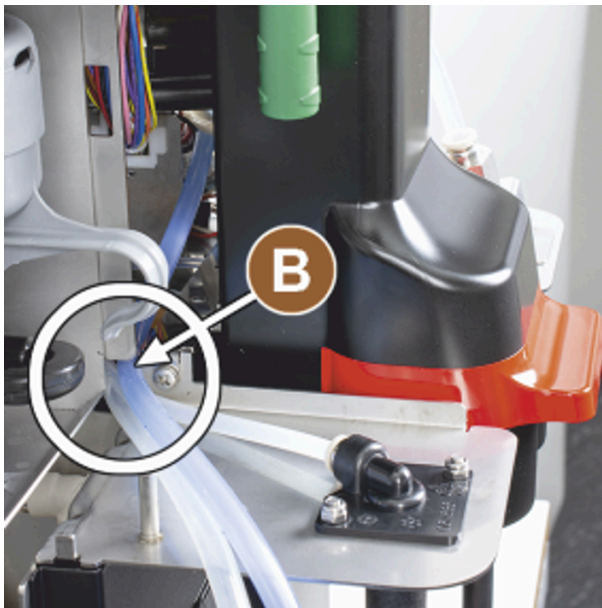

Figure: Milk hoses through plate opening

5. Guide the milk hoses through the sheet metal opening **(B)**.
  - ✓ Milk hoses lead out of the machine on the left side.

### 7.1.6 Assembling right housing and left milk hose guide

Prerequisite:

- Milk hoses are ready on the left side.
- The milk hose guide is ready.

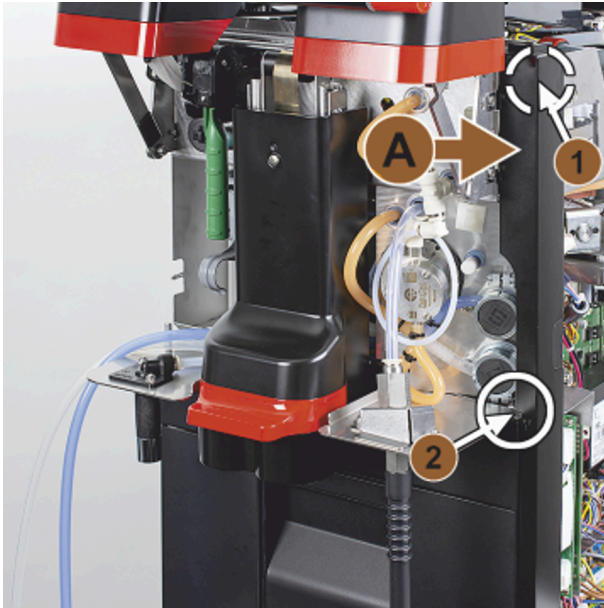

Figure: Assembly of the right side strip

1. Reassemble the right side strip **(A)**.
2. Note the fixings **(1)** and **(2)**.

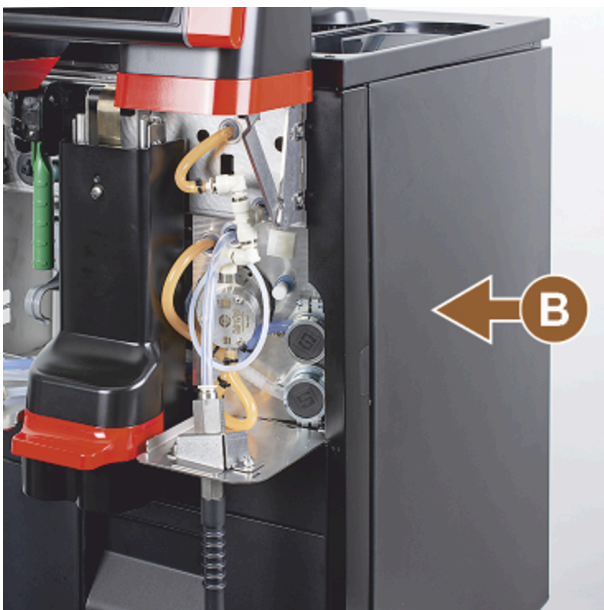

Figure: Assembly of the right side housing

3. Reassemble the right side housing **(3)**.

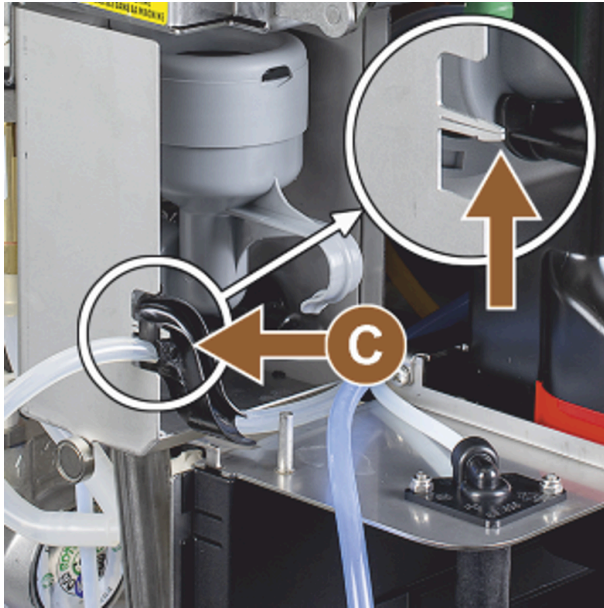

Figure: Milk hose guide

4. Attach the milk hose guide to the side panel **(C)**.
  - ✓ The milk hose guide is positioned.

Guiding milk hose out to the left

Prerequisite:

- Hose guide 079880 is positioned.

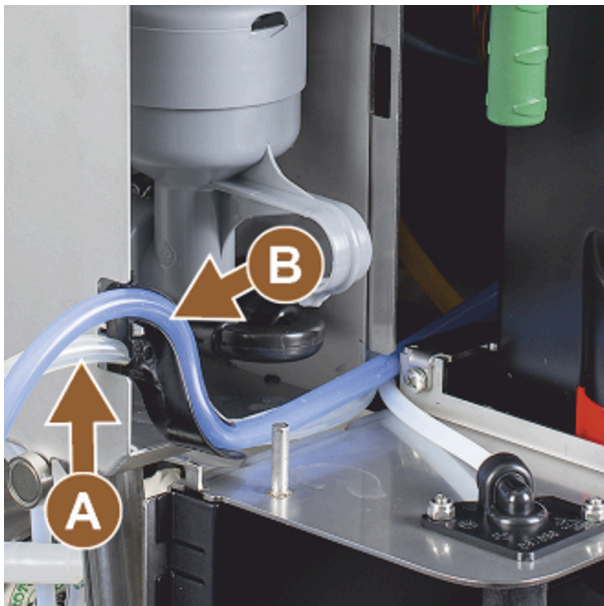

Figure: Milk hose in guide

1. Insert the milk hose **(A)** into the back of the hose guide.
2. Insert the milk hose **(B)** into the top of the hose guide.
  - ✓ Milk hoses are guided out of the machine on the left side.

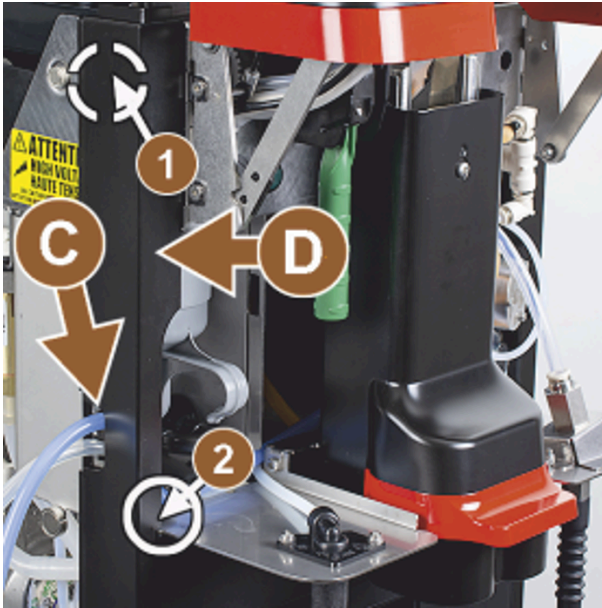

Figure: Milk hoses through side strip

3. Guide the milk hoses through the left side strip **(C)**.
4. Reassemble the left side strip **(D)**. Observe the fixings **(1)** and **(2)**.

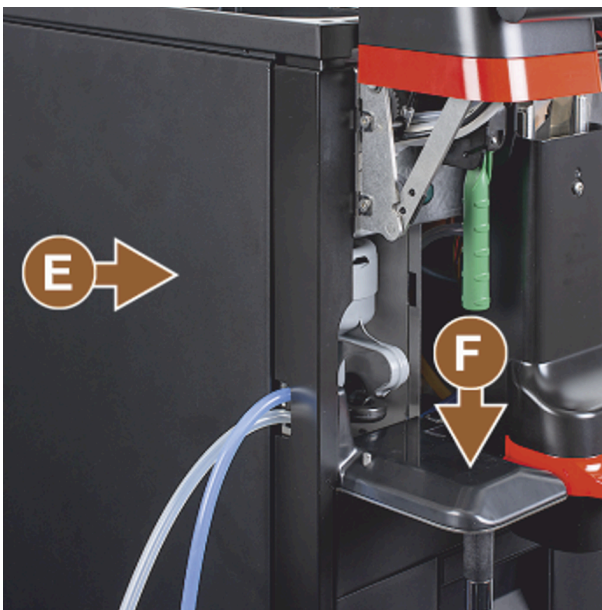

Figure: Assembling side housing

5. Attach the side housing **(E)**.
6. Attach the cover **(F)**.
7. Assemble the top housing and reinsert the containers.
  - ✓ The assembly of the milk hose to the left is complete.

## 8 Operation

### 8.1 Recurring additional tasks

#### 8.1.1 Filling bean hopper



#### WARNING

##### Cutting injuries!

Danger of injury from the rotating grinding discs in the grinder.

- ▶ Never reach into the bean hopper when the coffee machine is switched on.

#### ADVICE

##### Material damage due to clogging/blocking!

Filling the hopper with foreign objects can lead to clogging, blocking or destruction of the grinder.

- ▶ Never fill the bean hopper with anything other than coffee beans.

If necessary, clean the bean hoppers and covers to remove coffee residue before filling.



Figure: Bean hoppers with maximum filling quantity

- ▶ Variant with bean hopper locking mechanism: Open the bean hopper lock with the key.
- ▶ Remove the bean hopper cover.
- ▶ Fill the bean hopper with the intended type of coffee.
- ▶ Fill only so high that the contents do not touch the container cover.
- ▶ Close the bean hopper with the cover. Lock the bean hopper (if lockable).
  - ✓ The bean hopper is filled and locked.
  - ✓ Coffee beans do not touch the cover.

#### 8.1.2 Filling powder container



#### WARNING

##### Danger of crushing by the rotating dosing screws!

The dosing screws inside the powder containers rotate. There is a risk of crushing when reaching in.

- ▶ Never reach into the powder container when the device is switched on.

**ADVICE****Material damage due to blockage!**

There is a danger of blockage if prohibited coffee machine powder is filled into the machine.

- ▶ Never fill the powder container with anything other than powder for automatic operation.



Figure: Maximum fill level

1. Variant with powder container locking mechanism: Open the powder container lock with the key.
2. Remove the cover of the powder container.
3. Fill the powder container with choco or topping powder.
4. Fill only so high that the contents do not touch the container cover.
5. Close the powder container with the cover. Lock the powder container (if lockable).
  - ✓ The powder container is filled and locked.
  - ✓ The powder does not touch the cover.

### 8.1.3 Refilling water

#### Variant with mains water supply

**ADVICE****Material damage due to closed water supply line!**

The machine can suffer damage if the water pump runs dry.

- ▶ Before switching on the machine, make sure that the main water valve (tap) of the water supply line is open.

1. Open the shut-off valve on the main water valve before switching on the machine.
2. Close the main water valve at the end of the day.

#### Variant with external drinking water tank



Figure: External drinking water tank

1. Unscrew the cover of the external drinking water tank.
2. Rinse the external drinking water tank thoroughly with fresh water every day.
3. Clean the cover of the drinking water tank with fresh water.

4. Fill the drinking water tank with fresh drinking water, making sure not to exceed the maximum filling quantity.
5. Close the external drinking water tank with the cover.
6. Reinsert the drinking water tank.

### 8.1.4 Filling BestFoam™ milk system



#### CAUTION

##### Risk of infection due to contaminated milk!

Contamination in the milk pump can lead to health problems.

- ▶ Always carry out cleaning after installation, commissioning or recommissioning.
- ▶ Carry out the display-guided cleaning programme before dispensing a beverage for the first time.



#### ADVICE

##### Property damage due to milk that is not pre-cooled!

The cooling unit only maintains the temperature of pre-cooled milk.

- ▶ Only use milk that has already cooled down to at least 5 °C (41 °F) for refilling.



See 9.6 "Display-guided cleaning"

#### Side cooling unit

Filling quantity:

- Milk container of the side cooling unit = maximum 10 l

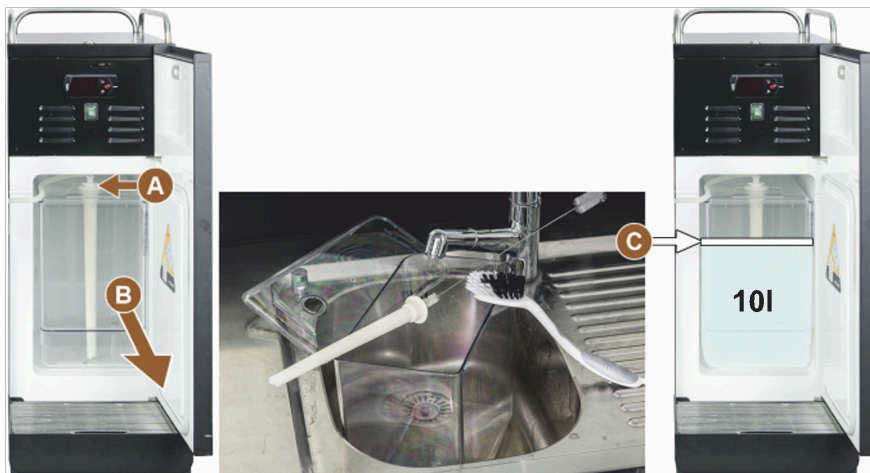

Figure: Cleaning and filling cooling unit

- A** Milk hose adapter
- B** Milk container

- C** Maximum fill level

**Cup & Cool, under-machine cooling unit and under-counter cooling unit**

Filling quantities:

- Milk container of Cup & Cool = maximum 4 l
- Milk container of under-machine cooling unit (UMCU) = maximum 9.5 l
- Milk container of under-counter cooling unit (UCCU) = maximum 9.5 l

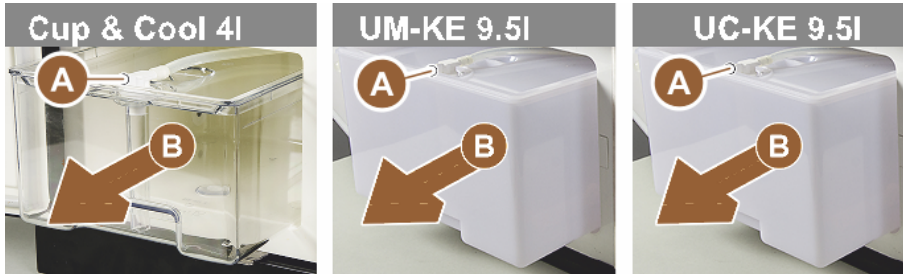

Figure: Refilling milk, various options

- A** Milk hose adapter
- B** Milk container

1. Open the door of the cooling unit.
2. Remove the adapter from the milk hose **(A)** from the milk container cover.
3. Pull out the milk container **(B)**.
4. Lift off the milk container cover.
5. Rinse the milk container, riser pipe and cover with fresh water.
6. Fill with milk and observe the maximum fill quantity **(C)**.
  - ✓ The milk must not touch the milk container cover.
7. Close the milk container with the milk container cover.
8. Insert the milk container into the cooling unit.
9. Insert the adapter from the milk hose into the milk container cover.
10. Close the door of the cooling unit.



Regularly check if the cooling temperature is between 3 – 5 °C (37.4 – 41 °F).

**8.1.5 Filling the Flavour Point (optional) or changing bottles**

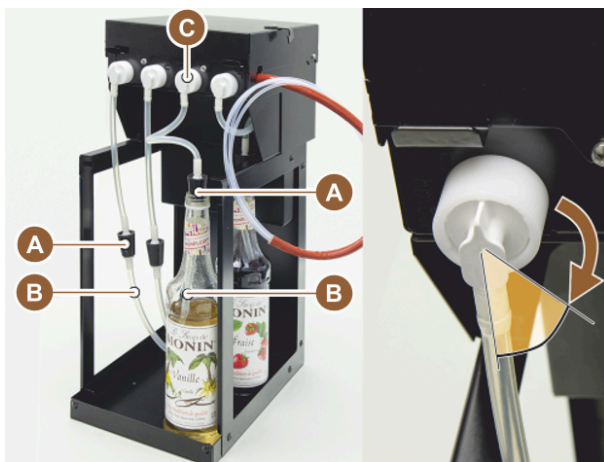

Figure: Flavour Point: Refill or bottle change

- A** Plugs
- B** Syrup hose
- C** Hose adapter

1. Place the syrup bottles (max. 4 bottles) in the Flavour Point.
2. Remove the cap from each bottle.
3. Insert the stopper **(A)** with hose **(B)** into the bottle and press the stopper firmly into place.
4. Insert the adapter **(C)** into the Flavour Point and lock the bayonet catch by turning it to the right.
5. Repeat the above steps for all syrup bottles.

After connecting the syrup bottles, the syrup hose must be filled. The **Ingredient management** routine in the Service menu is used for this purpose.



See 8.8.5 "Scope of functions", „Ingredient management“

### 8.1.6 Opening and closing user panel



#### CAUTION

#### Risk of crushing due to falling user panel!

The user panel can fall under its own weight.

- ▶ Hold the user panel firmly and move it up or down in a controlled manner until it clicks into place.

#### Opening user panel



Figure: Opening user panel

- 1** Lock engaged
- 2** Lock disengaged
- 3** Top side of user panel released
- 4** User panel pushed upwards

1. Move the key in the closing device **(1)** to the horizontal position.
  - ✓ The lock is open **(2)**.
2. Unlock the user panel at the top **(3)** by pulling firmly.
  - ✓ The user panel is unlocked.
3. Push the user panel upwards from below **(4)** with both hands as far as it will go.



Figure: User panel closed and opened

- ✓ The user panel is automatically held in the upper position.
- ✓ All operating elements behind the user panel are now accessible.

### Closing user panel



The machine is only ready for use when the user panel is closed.

Prerequisite:

- The closing device of the user panel can only be closed when the locking mechanisms of the bean hoppers and powder containers are closed.
1. Push the user panel down slightly with both hands as far as it will go.
  2. Gently press in the upper edge of the user panel.
    - ✓ The user panel is closed.
  3. If necessary, lock the closing device again with the key.
    - ✓ The lock is closed when in the vertical position.
    - ✓ The user panel is locked.

## 8.1.7 Removing bean hoppers and powder container

The bean hoppers or powder container can be removed from the machine. The central locking mechanism unlocks the bean hoppers and powder container.

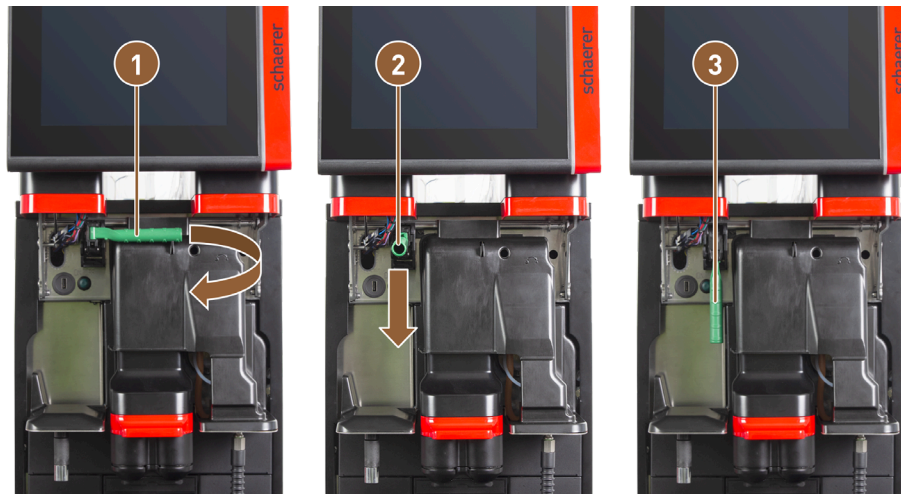

Figure: Bean hopper and powder container release (option)

- 1** Horizontal position: Bean hopper locked

**2** Position to the front
- 3** Position to the rear: Bean hopper unlocked

1. Open the user panel.
2. Swivel the green handle of the central locking mechanism forward from the horizontally folded position **(1)** to position **(2)**.
3. Fold the green handle of the central locking mechanism **(2)** downwards.
  - ✓ The bean hoppers and powder containers are now unlocked. The green handle of the central locking mechanism is in position **(3)**.



See 8.1.6 "Opening and closing user panel"

### 8.1.8 Inserting ProCare cleaning bags

One ProCare cleaning bag is enough for about 100 cleanings. Empty cleaning bags must then be disposed of.

The cleaning bags are filled with the cleaning powder and sealed. The blue cleaning bag contains an alkaline-based cleaning product, the red bag contains an acid-based cleaning product.



Figure: Opening ProCare

**1** Drawer with collecting tray

1. Open the cam lock and pull out the drawer with the drip tray **(1)** and the cleaning bags. The cam lock is located under the milk connection flap (Plug&Clean).



Figure: Removing cleaning bags

**2** Cap nuts

2. Loosen the cap nuts **(2)** from the cleaning bags.
3. Remove and dispose of the empty cleaning bags.
4. Remove the end caps and the protective film from the new ProCare cleaning bags.
5. Place the new ProCare cleaning bags on the free coupling nozzles and tighten the end caps of the cleaning bags with the cap nuts.



The couplings are not the same size. That means cleaning bags cannot be mixed up.



Figure: Inserting drawer

1 Drawer

6. Push the drawer **(1)** back into the housing and close the ProCare.
  - ✓ A dialogue with the **ProCare** message: **Cleaning bag inserted** opens.
7. Confirm with **OK**.
  - ✓ The screen for conditioning the used cleaning bag opens.

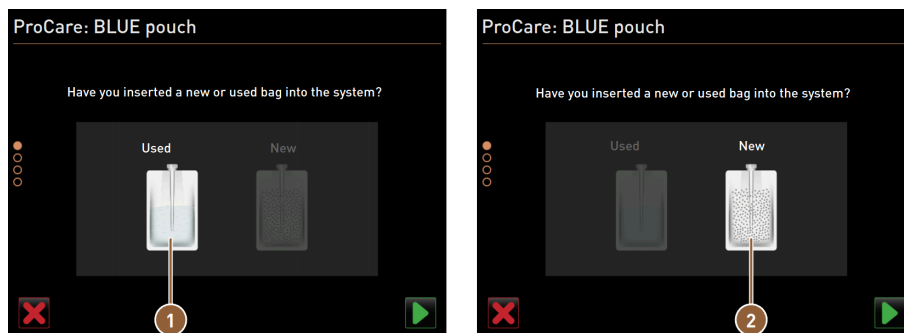

Figure: ProCare BLUE example: Changing cleaning bags

1 Used cleaning bag: Air is extracted.

2 New cleaning bag: Is filled with water, then the air is extracted.

8. Tap on **Used** if you have inserted a used cleaning bag or on **New** if you have inserted a new cleaning bag.
9. Confirm the selection with **▶**.
  - ✓ The air is now extracted from an already used cleaning bag **(1)**. A new cleaning bag **(2)** is filled with water and the air is then extracted.
  - ✓ A confirmation dialogue with the **ProCare** message: **Bag exchange successful** opens.
10. Confirm with **▶**.
  - ✓ The cleaning bag(s) has (have) been inserted and conditioned. ProCare is ready for cleaning processes.

The same process can be initiated manually in the Service menu.

#### To change the bag with the Service menu:

1. Open the Service menu with **⚙**.
2. Tap on the **Maintenance intervals** button.

	Last done	Due
Descaling	6/18/2024	in 6 months 571 litres
Maintenance 2	11/22/2023	39990 coffee beverages left
Maint. 24 months	11/22/2023	in 17 months
ProCare: RED pouch	6/6/2024	99% remaining <b>1</b>
ProCare: BLUE pouch	6/6/2024	97% remaining <b>2</b>

Figure: Display of the remaining content

**1** Cleaning bag red

**2** Cleaning bag blue

- In the **Maintenance interval** screen, tap on the button for the **ProCare:** menu item **Bag RED** or **ProCare: Bag BLUE**.
- Change the bag or cancel the process.
  - ✓ You will be taken back to the main menu.

## 8.2 Switching on

### 8.2.1 Check before switching on



#### ADVICE

##### Material damage due to closed water supply line!

The machine can suffer damage if the water pump runs dry.

- ▶ Before switching on the machine, make sure that the main water valve (tap) of the water supply line is open.

- With mains water supply: Make sure that the main water valve is open.
- For drinking water tank: Make sure that the drinking water tank is filled with fresh water.
- With standard waste water outlet: Make sure that the waste water hose is laid correctly.
- With external waste water tank: Make sure that the external waste water tank is connected and empty.
- Make sure that the bean hoppers are filled.
- Make sure that the grounds container is empty and correctly inserted.
- Make sure the machine is correctly connected to the manufacturer-side mains in accordance with national or local safety regulations.

## 8.2.2 Switching on machine

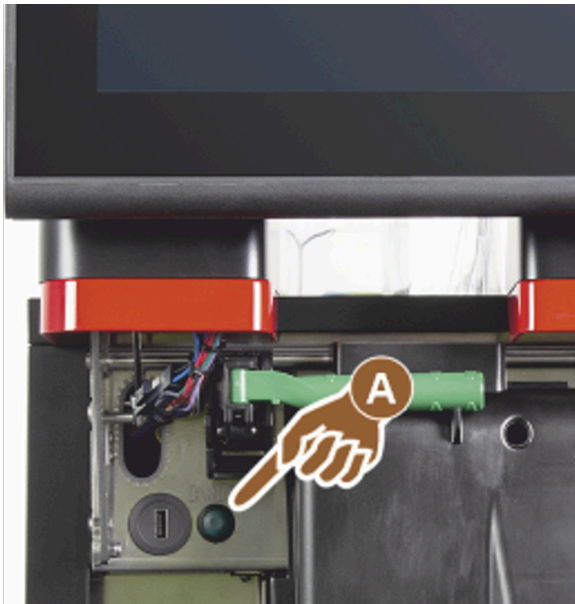

Figure: Switch-on button

1. Check the mains connection of the machine.
2. Unlock the user panel.
3. Push the user panel firmly upwards.
4. Briefly press the switch-on button **(A)**.
  - ✓ The machine starts up.
  - ✓ The main screen user interface appears in the touch screen, the machine begins to heat up.
  - ✓ The machine is ready for use as soon as the required temperature is reached.
5. Close the user panel.



When the machine is switched on for the first time, display-guided setting of the machine configuration and hardware calibration follow automatically.



See 8.1.6 "Opening and closing user panel"

### 8.2.3 Switching on Cup & Cool/cup warmer (option)

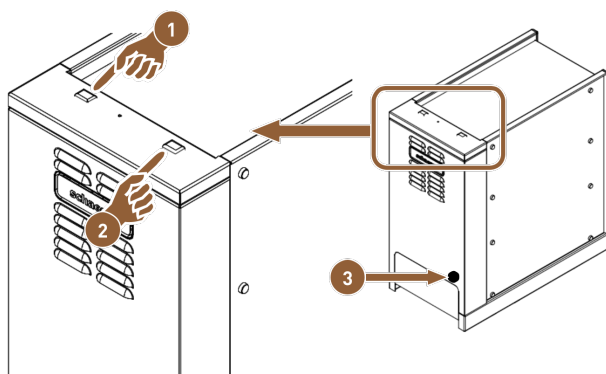

Figure: Switching on and setting the Cup & Cool optional accessory

- ❶ Cooling unit on/off toggle switch
  - ❷ Cup warmer on/off toggle switch
- ❸ Thermostat setting

1. Switch the toggle switch **(1)** to position **I**.
2. If necessary, adjust the temperature using the thermostat on the back **(3)**.
  - ✓ The cooling unit is switched on.
3. Switch the toggle switch **(2)** to position **I**.
  - ✓ The cup warmer is switched on.



For optional accessories, also see the detailed information in the separate description for optional accessories.

### 8.2.4 Switching on side cooling unit (optional)



Figure: Switching on side cooling unit

1. Open the door of the cooling unit.
2. Switch the toggle switch **(A)** to position **I**.
3. Hold the button **(B)** down for approx. 3 s.

- ✓ The device is switched on.
- ✓ The current interior temperature of the cooling unit is shown on the display.

#### Switching cooling unit to standby

- ▶ Hold the button **(B)** down for approx. 3 s.
  - ✓ The cooling unit switches to Standby mode.

#### Setting temperature

1. Hold the button **(B)** down for approx. 3 s.
2. Set the temperature 3 – 5 °C (37.4 – 41 °F) higher with button **(B)** or lower with button **(D)**.
3. Confirm the setting with the button **(C)**.
  - ✓ The cooling unit switches to the operating mode.
  - ✓ The current interior temperature of the cooling unit is shown on the display.



For optional accessories, also see the detailed information in the separate description for optional accessories.

### 8.2.5 Switching on under-counter or under-machine cooling unit (optional)

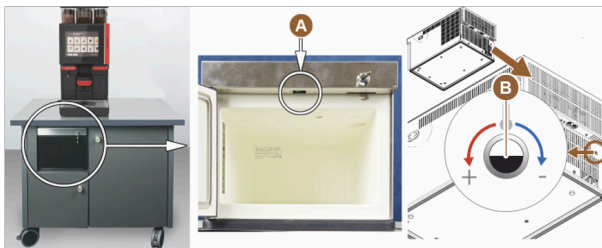

Figure: Switching on and adjusting under-counter cooling unit

- (A)** Cooling unit on/off toggle switch (rear door)
- (B)** Cooling unit thermostat (rear side)

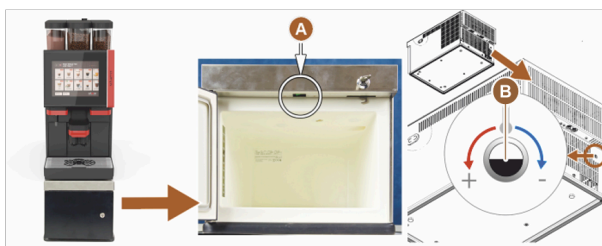

Figure: Switching on and setting under-machine cooling unit

- (A)** On/Off toggle switch (rear door)
- (B)** Cooling unit thermostat (rear side)

1. Open the door.
2. Switch the toggle switch **(A)** to position **I**.
3. Set the thermostat on the back to the centre position **(B)**.
  - ✓ The under-counter cooling unit is switched on.



For optional accessories, also see the detailed information in the separate description for optional accessories.

### 8.2.6 Switching on the Flavour Point (optional)



Figure: Switching on the Flavour Point

- ▶ Switch the toggle switch **(A)** to position **I**.
  - ✓ The **Flavour Point** syrup module is switched on.

### 8.3 Positioning beverage outlet



Figure: Positioning beverage outlet

#### Positioning beverage outlet (with manual beverage outlet)

- ▶ Guide the beverage outlet up to the cup using the handle.

### Positioning beverage outlet (with automatic height-adjustable beverage outlet)

The AHA (automatic height-adjustable beverage outlet) automatically adjusts to the correct outlet height for the previously selected beverage.

## 8.4 Operating modes

The user interface of the machine can be set to one of the following operating modes by service technicians:

- Guest mode
- Staff mode
- Frequent user mode

### 8.4.1 Functions of operating mode

The user interfaces in the various operating modes (**Guest mode**, **Staff mode** and **Frequent user mode**) have different functions and messages.

The following table provides an overview of the active functions and displays in the standard setting.

Operating mode	Guest mode	Staff mode	Frequent user mode
<b>Display of notification mode</b>	<b>Simple</b>	<b>Specific</b>	<b>Specific</b>
Double button visible	0	ON	0
<b>DECAF</b> button visible	0	ON	0
<b>Barista</b> button visible	0	0	ON
<b>Cup size</b> button visible	0	0	0
Beverage icons visible	ON	ON	ON
Icon set	Paper cups	Default	Paper cups
Screensaver	ON	0	ON
Beverage groups	Individual	Individual	Individual
Activate beverage pre-selection	0	ON	0
Enable preselection on touch screen	0	ON	0
Number of positions in the preselection	0	0 – 8 (8)	0
Enable preselection using external buttons	0	0	0
Beverage preselection section left	0	ON	0
Beverage preselection section right	0	ON	0
<b>Warm-up rinsing</b> button visible	0	0	0
<b>Service</b> button visible	ON	ON	ON

Operating mode	Guest mode	Staff mode	Frequent user mode
Show group selection	0	0	0
Sequential beverage modification	ON	0	0
Display <b>position cup</b>	0	0	ON
Display <b>progress</b>	ON	0	ON
Display <b>beverage complete</b>	ON	0	0
Display <b>beverage complete</b> interruption	0.5 – 60 s (3 s)	0.5 – 60 s (3 s)	0.5 – 60 s (3 s)
Access to Service menu	PIN	PIN	PIN

0 (red) Inactive by default; activation is not possible.

0 (yellow) Inactive by default; activation is possible.

ON (green) Active by default; deactivation is possible.

ON (white) Active by default; deactivation is not possible.

## 8.4.2 Guest mode

The preconfigured **Guest mode** user interface supports operation of the machine by guests without any knowledge of the machine.

Guest mode is the operating mode with the smallest range of functions. Service technicians can also make individual settings.

In Guest mode, pre-selection of beverages (double beverages, decaffeinated coffee, barista) is not possible.

Available beverages are displayed in groups.

### Prerequisite:

The **Display group selection** function is activated in this operating mode.

Navigation through the menu for beverage dispensing is done step-by-step.

### Quantity structure of groups and beverages:

- 10 tabs (groups)
- 24 beverages per tab (group)
- A maximum of 240 beverages are available.

### Possible functions in Guest mode:



Figure: **Guest mode** standard user interface



Figure: Beverage groups in Guest mode and Frequent user mode

**(A)** Display of a maximum of 240 beverages (10 groups with a maximum of 24 beverages each)

**(B)** Navigation through beverage groups (arrow)

**(C)** Access to service menu

**(D)** Selection via beverage groups

**Steps to beverage dispensing:**

- Select desired beverage
- Choose cup/mug size
- Select coffee roast (option)
- Confirm selection
- Payment (with payment system, option)
- Place cup/mug request
- Start dispensing
- Fill ground coffee (with separate manual inlet)
- Confirm manual inlet
- Beverage is dispensed.
- Display of beverage dispensing progress
- **Beverage complete** display

Service technicians can extend or reduce the standard configuration with the following additional functions:

- Screensaver image *ON*
- **Service menu (C)** button visible *ON*

- Group selection **(D)** (maximum 10 groups with horizontal navigation **(B)** possible) *OFF*
- Sequential beverage modification *ON*-fixed
- **Position cup/mug** instruction *ON*
- Display **Progress** information *ON*-fixed
- Display **Beverage complete** information *ON*

### 8.4.3 Staff mode

The preconfigured **Staff mode** user interface supports operation of the machine by operating staff with machine knowledge. Beverages are selected exclusively by qualified staff.

Staff mode is the operating mode with the largest range of functions.

In Staff mode, pre-selection of beverages (double beverages, decaffeinated coffee, barista) is possible. The **Select group** screen is not available.

Instead, the groups are displayed on tabs at the top. A vertical menu is also available on the left. The beverage groups and tabs can be named and assigned as needed by service technicians.

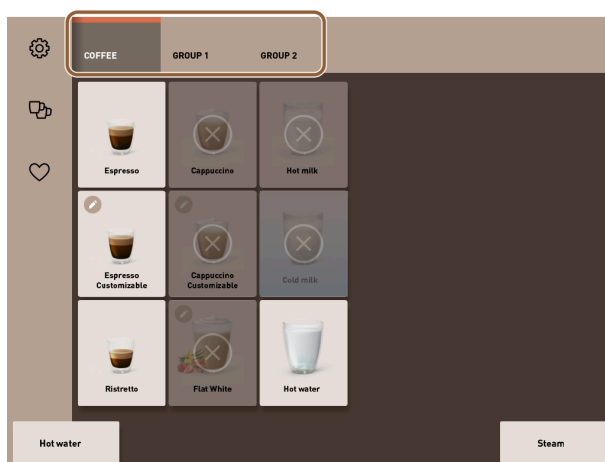

Figure: Tabs in Staff mode

Modification of beverages is displayed and carried out in its entirety on the **Dispense beverage** screen. An autostart can be activated for predefined beverages.

#### Quantity structure of groups and beverages:

- 10 tabs (groups)
- 24 beverages per tab (group)
- A maximum of 240 beverages are available.



Figure: **Staff mode** standard user interface

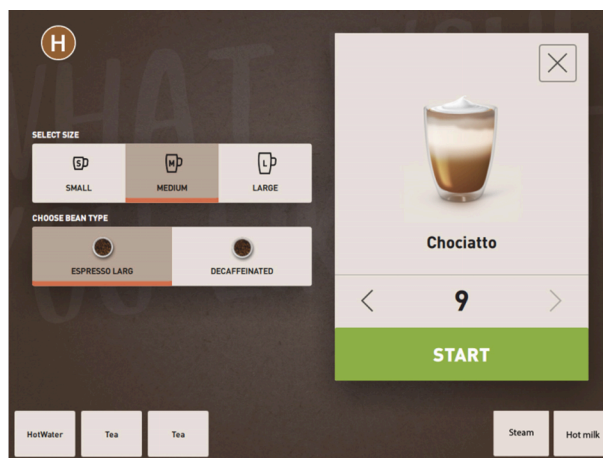

Figure: Selection of beverage options in Staff mode

#### Possible functions in Staff mode:

- (A) Display of a maximum of 24 beverage fields per group (10 possible groups)
- (B) Horizontal wiping scroll function (finger)
- (C) Beverage filter (DECAF, double beverage)
- (D) Access to Service menu
- (E) **Barista** preselection (coffee strength) *OFF*
- (F) Maximum 3 separate additional beverages (left)
- (G) Maximum 2 separate additional beverages (right)
- (H) Screen for selection of beverage options

#### Steps to beverage dispensing:

- Preselection (e.g. DECAF or double beverage)
- Preselection of coffee strength (barista)
- Select desired beverage
- Define beverage options
- Payment (with payment system, option)
- Start dispensing
- Fill ground coffee (with separate manual inlet)
- Confirm manual inlet
- Beverage is dispensed.
- Display of beverage dispensing progress

Service technicians can extend or reduce the standard configuration with the following additional functions:

- **(C)** button for double beverage dispensing *ON*
- **(C)** button for decaffeinated coffee (DECAF) *ON*
- **(E)** button for coffee strength (barista) *OFF*
- Beverage preselection possible (multiple dispensing) *ON*
- Display of number of preselected beverages *OFF*
- **Service menu button (D)** visible *ON*
- Display of **Position cup/mug** information *OFF*
- Display of **Progress** information *OFF*
- Display **Beverage complete** information *OFF*

#### 8.4.4 Frequent user mode

The preconfigured **Frequent user mode** user interface allows for operation of the machine by advanced operators (office area). The service technician can also make individual settings.

In Frequent user mode, pre-selection of beverages (double beverages, decaffeinated coffee, barista) is not possible. The tabs at the top and the vertical menu on the left are not available.

Frequent user mode is the operating mode with a medium range of functions. Service technicians can also make individual settings.

Modification of beverages is displayed and carried out in its entirety on the **Dispense beverage** screen.

Available beverages are displayed in groups.

##### Prerequisite:

The **Display group selection** function is activated in this operating mode.

Navigation through the menu for beverage dispensing is done step-by-step.

##### Quantity structure of groups and beverages:

- 10 tabs (groups)
- 24 beverages per tab (group)
- A maximum of 240 beverages are available.



Figure: **Frequent user mode** interface

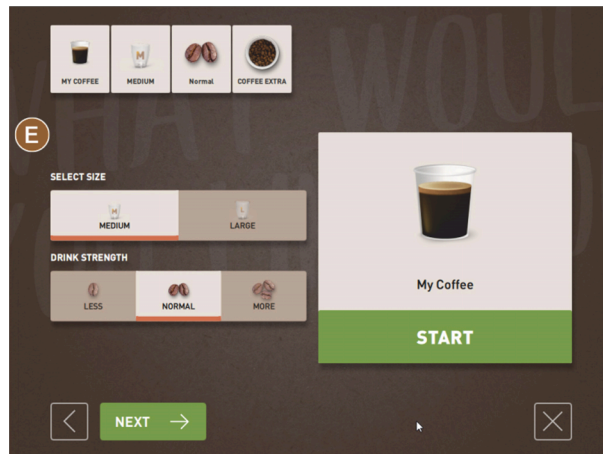

Figure: Selection of beverage options in Frequent user mode



Figure: Beverage groups in Guest mode and Frequent user mode

**Possible functions in Frequent user mode:**

- (A) Display of a maximum of 240 beverages (10 groups with a maximum of 24 beverages)
- (B) Navigation through beverage groups (arrow)
- (C) Access to service menu
- (D) Maximum 3 separate additional beverages (left)
- (E) Screen for selection of beverage options
- (F) Selection via beverage groups

**Steps to beverage dispensing:**

- Select desired beverage
- Choose cup/mug size
- Select coffee roast (option)
- Confirm selection
- Payment (with payment system, option)
- Place cup/mug request
- Start dispensing
- Fill ground coffee (with separate manual inlet)
- Confirm manual inlet
- Beverage is dispensed.

Service technicians can extend or reduce the standard configuration with the following additional functions:

- **(E)** button for coffee strength (barista) *ON*
- Screensaver image *ON*
- **Service menu (C)** button visible *ON*
- Group selection **(F)** (maximum 10 groups with horizontal navigation **(B)** possible) *OFF*
- **Position cup/mug** instruction *ON*
- Display **Beverage complete** information *OFF*

## 8.5 Beverage supply

### Limited beverage selection

Machines with external drinking water tank are restricted in the beverage selection. It is not possible to dispense cooled beverages with an external drinking water tank.

Powdered beverages are **always** dispensed hot with an external drinking water tank, regardless of the set temperature.

### Cancellation of beverage selection after inactivity

Beverage selection can be automatically cancelled after a period of inactivity of 5 – 40 s.

In this case, the user interface is displayed for a new beverage selection process.

The time period can be adjusted by service technicians in the **Configuration > Operating mode > Reset selection time-out** settings.

### 8.5.1 Selecting beverage

#### Navigating to beverage

Prerequisite: The machine is ready for use.



Figure: Guest mode and Frequent user mode: Scrolling to beverage

- ▶ Use the arrow buttons **(1)** to scroll through the beverage displays.
  - ✓ The desired beverage button appears.



Figure: Staff mode: Direction selection of beverage group

- ▶ Open the desired beverage group **(1)** directly via the corresponding tab.
  - ✓ The saved beverage buttons appear.

### Staff mode: Preselecting beverage options

Prerequisite: The user interface is in **Staff mode**.

Possible preselections in the menu:

- Double beverage dispensing
- Decaffeinated coffee
- Coffee strength (barista)

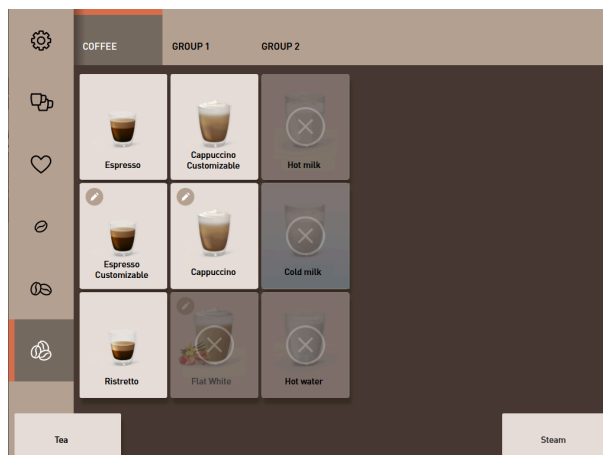

Figure: Beverage preselection in the left menu

- ▶ Select a beverage option via a preselection in the left menu, e.g. coffee strength.
  - ✓ All beverages with the corresponding option appear.

### Staff mode: Selecting beverage type

Prerequisite: The tab with the beverage group or the preselection contains configured beverages.



Figure: Beverage types

- ▶ Tap on the desired beverage button.
  - ✓ A screen with more beverage options opens.

## 8.5.2 Modifying beverage

Possible beverage options:

- Beverage type (e.g. coffee, espresso, cappuccino)
- Beverage size (S, M, L)
- Coffee type (2-3 grinders)
- Milk type (Twin Milk)
- Chocolate (with powder system)
- Aroma (with Flavour Point syrup system)

Prerequisite: The selected beverage is marked as modifiable with the pencil icon .

The preselection of ingredients and beverage size can be set and activated by service technicians in the beverage configuration.

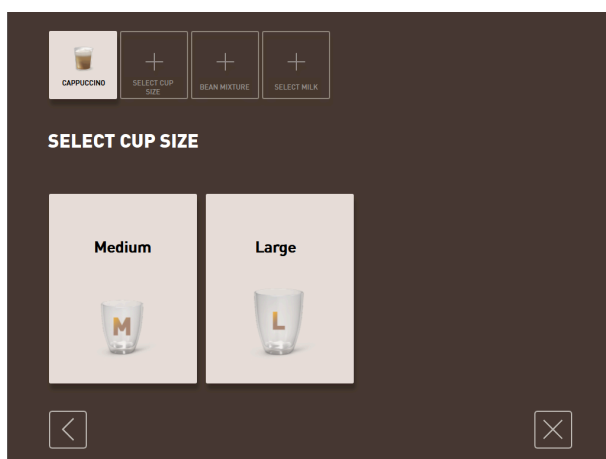

Figure: Guest mode: Determining beverage modification sequentially

1. Tap on the button with the desired modification.
  - ✓ The desired modification appears.
  - ✓ Other modifications are displayed for selection.
2. Select the additional modifications.

### Sequential beverage modification

**Sequential beverage modification** is active in Guest mode and cannot be deactivated.

**Sequential beverage modification** asks for a preselection of beverage options step by step. The options are each offered for selection in a separate display.

### Progress display for sequential beverage modification

Prerequisite:

- The beverage is configured for dispensing with different ingredients.
- The **Beverage selection progress** type of display is available in Guest mode.

The progress display provides information about the beverage options already selected and those still to be selected.

Each selected ingredient is displayed by a symbol.

Each step still to be selected is shown with an empty display field.

The **Beverage selection progress** display cannot be deactivated.



Figure: Selection of beverage

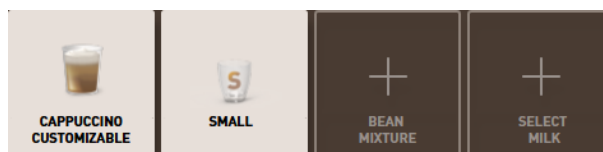

Figure: Selection of beverage size

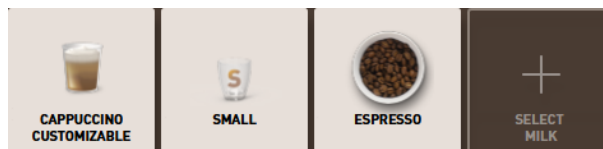

Figure: Selection of coffee type

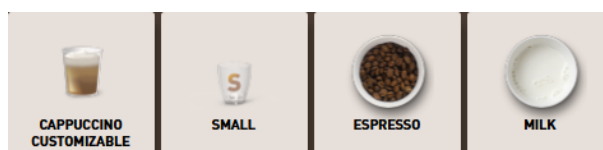

Figure: Selection of ingredients

### Direct beverage modification

**Direct beverage modification** is active in Staff mode and in Frequent user mode and cannot be deactivated.

With this function, the selection of beverage options is offered directly in the same display.



Figure: Staff mode: Directly choosing beverage modification

1. Tap on the button with the desired modification **(1)**.
2. If necessary, set multiple dispensing **(2)** (1 to 9 beverages).
  - ✓ The selected modifications are active.



Figure: Frequent user mode: Directly choosing beverage modification

- ▶ Tap on the button with the desired modification **(1)**.
  - ✓ The selected modifications are displayed summarised in the upper area **(2)**.

### 8.5.3 Preselecting double beverage

Double beverages can be dispensed in Staff mode. This allows two cups to be filled at the same time, with the respective quantity per cup being dispensed once on the left-hand side and once on the right-hand side of the beverage outlet.

Prerequisite:

- The **Double button visible** function is activated in Staff mode.
- Beverages with double dispensing have been configured.



Figure: Double beverage preselection

To activate double beverage dispensing:

- ▶ Tap on the **Double beverage dispensing** button.
  - ✓ All beverages which are configured for double beverage dispensing are actively displayed for selection in the user interface.

The preselection option for double beverages can be set by service technicians in the beverage configuration.

## 8.5.4 Dispensing preselected beverages multiple times

The function is available if the parameter is activated in the **Configuration > Operating mode > Activate preselection via touch screen** setting.

### Multiple dispensing (Staff mode)

Prerequisite: The preselection is activated in operating mode (maximum 1 – 9 beverages).

Preselection for several beverages is only available in **Staff mode**.

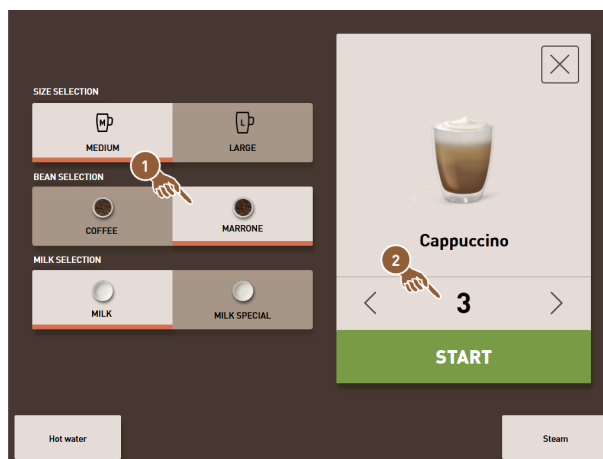

Figure: Display of beverages

1. Select a beverage.
2. Select the desired ingredients.
3. Set the number of beverages using the arrow buttons < 1 – 9 >.
  - ✓ The beverage dispensing process is repeated a maximum of nine times.
  - ✓ The progress of all dispensing processes is shown.

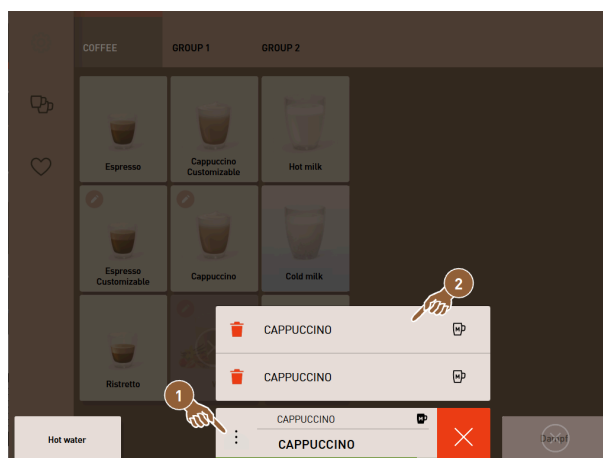

Figure: List with preselected beverages

4. Tap on the three-dot menu **(1)**.
  - ✓ A list with the preselected beverages **(2)** appears.
  - ✓ When beverage dispensing is complete, this is displayed in green.
5. Remove the cup or mug from the beverage outlet.

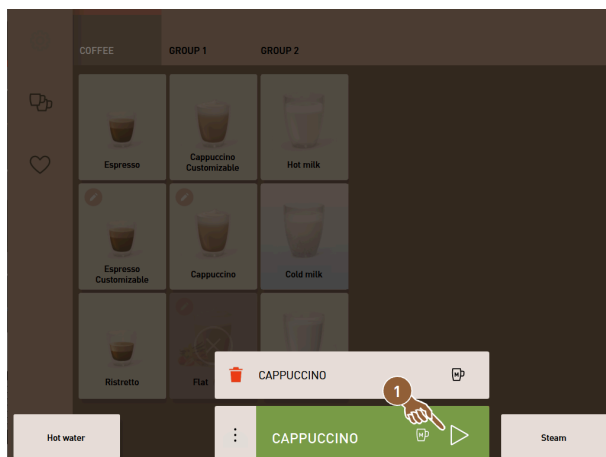

Figure: Dispensing additional beverage

6. Tap on the **Play (1)** button.
  - ✓ The first beverage dispensing is confirmed.
  - ✓ Dispensing for the next beverage in the list starts.
7. Repeat step 3 for the other beverages.

### 8.5.5 Preselecting decaffeinated coffee

In Staff mode, decaffeinated coffee can be preselected directly. This means that only beverages for which a variant with decaffeinated coffee is available are displayed as active.

Prerequisite:

- The **DECAF button visible** function is activated in Staff mode.
- The machine is equipped with two bean hoppers, one of which is filled with decaffeinated beans.
- Alternatively, the machine can be filled with decaffeinated ground coffee through the manual inlet.



Figure: Decaffeinated coffee preselection

Variant with second grinder

- ▶ Tap on the **Without caffeine** button.
  - ✓ Only the beverages that have been configured with decaffeinated coffee beans are available for selection.

Variant with ground coffee and manual inlet

- ▶ Tap on the **Without caffeine** button.
  - ✓ Only the beverages that have been configured as a source with **DECAF** are available for selection.
  - ✓ When dispensing, a request for filling the decaffeinated ground coffee appears.



See 8.6 "Using manual inlet"

The **decaffeinated coffee** preselection can be set by service technicians in the beverage configuration.

## 8.5.6 Barista preselection

In Staff mode, the strength of the beverage to be dispensed can be influenced once using the **Barista** function.

Three settings are available: **Mild**, **medium** and **strong**.

After the beverage has been dispensed, the barista field returns to the standard setting of **medium**.

Prerequisite:

- The **Barista** function is available for activation in Staff mode.
- The beverage has been configured with the **Barista** function.

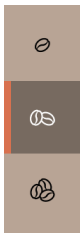

Figure: Barista preselection

To change the beverage strength:

- ▶ Tap on the button with the desired coffee strength.
  - ✓ Only those beverages whose strength can be adjusted are available for selection.

The **Barista** preselection can be activated in Staff mode by service technicians.

## 8.5.7 Positioning cup/mug

Prerequisite: The **Position cup** function is activated in the operating mode.

During beverage dispensing, an instruction to position the cup or mug appears.



Figure: The **Position cup/mug** animation is shown in the display.

1. Place the cup or mug under the beverage outlet.
2. For manual beverage outlet: Pull the beverage outlet down onto the cup or mug.

The **Position cup** instruction can be activated in the operating mode by service technicians.

## 8.5.8 Paying for beverage

Prerequisite: A payment system is activated and the beverage contains a beverage price.

If a payment system is activated, an instruction for payment appears first.

The selected beverage options are confirmed with the **PAY** button. The payment process is then started.

Once the payment process has been completed, the **PAY** button changes to the **START** button.

The **START** button starts the beverage dispensing process.

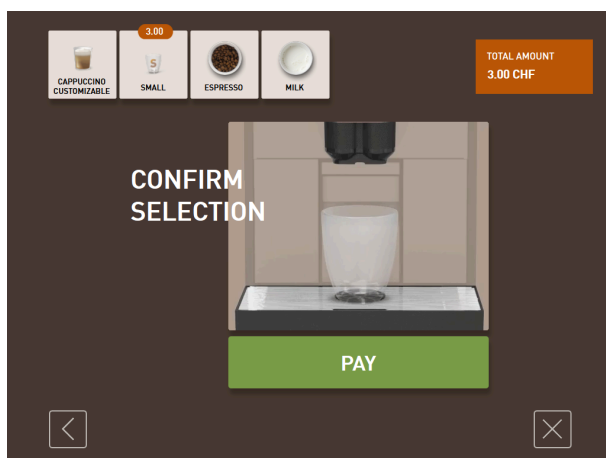

Figure: Button for payment

1. Tap on the **Pay** button.

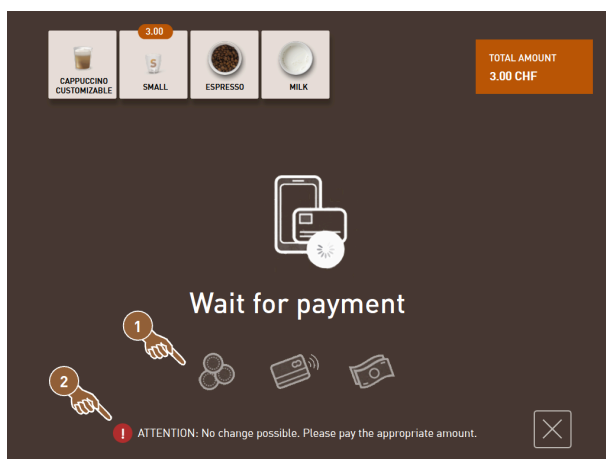

Figure: Instruction for payment

- ✓ The screen with the payment methods offered (**1**) appears.
  - ✓ In the case of coin change systems, (**2**) is displayed if it is no longer possible to change coins.
2. Select an available payment method.
  3. Confirm the payment process and complete the payment process.
    - ✓ Beverage dispensing starts.

## 8.5.9 Dispensing beverage

### Variant: Dispensing without payment system

Prerequisite: Beverage modification is complete and the beverage is ready for dispensing.

The **START** button appears once beverage preselection has been completed.

The **START** button confirms the selected beverage options and starts the beverage dispensing process.

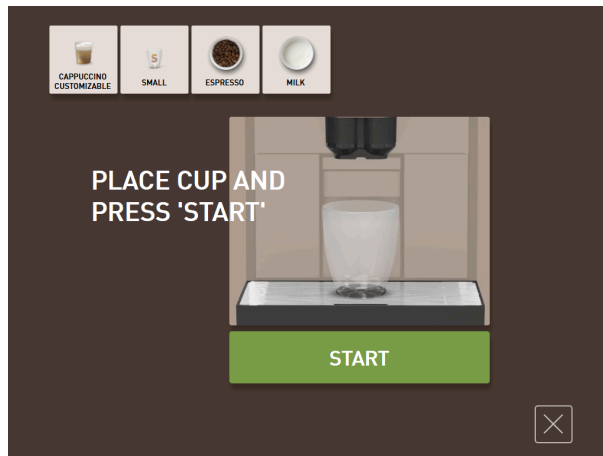

Figure: Beverage ready for dispensing

1. Tap on the **START** button.
  - ✓ The **Position cup** instruction appears.
2. Tap on the **START** button again.
  - ✓ The beverage is dispensed.

The **Position cup** instruction can be activated or deactivated by service technicians in the configuration for the respective operating mode.

## 8.5.10 Progress display for beverage dispensing

Prerequisite: Beverage dispensing starts.

**Variant: Guest mode/Frequent user mode**

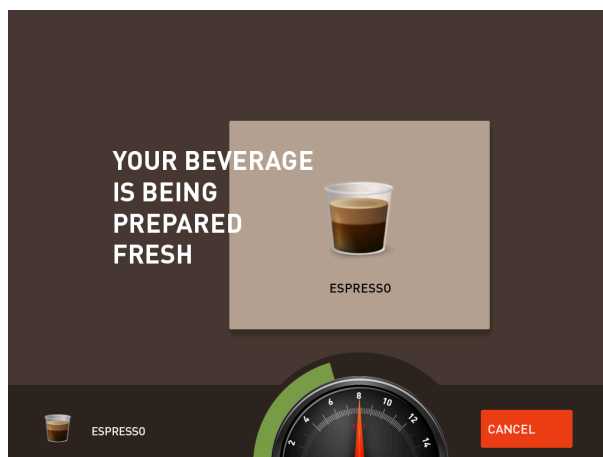

Figure: Progress (Guest and Frequent user mode)

### Guest mode and Frequent user mode: Displaying progress

- The progress is displayed as a green bar in a semicircle. The dynamic green bar goes around the digital manometer from left to right in a semicircle.
- The digital manometer provides information on the current water pressure during coffee brewing.

- The progress display provides information about the remaining dispensing time during beverage dispensing.
- The progress screen can be activated in the operating mode.

#### Variant: Staff mode

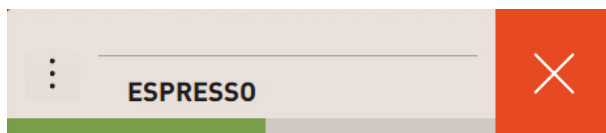

Figure: Progress (Staff mode)

#### Staff mode: Displaying progress

- The progress is displayed as a green bar.
- The dynamic green bar runs horizontally from left to right.
- The progress screen with a bar can be activated in the operating mode.

### 8.5.11 Completion of beverage

If dispensing is complete, the display indicates this.

Prerequisite: The information appears if the parameter is activated in the **Configuration > Operating mode** setting.

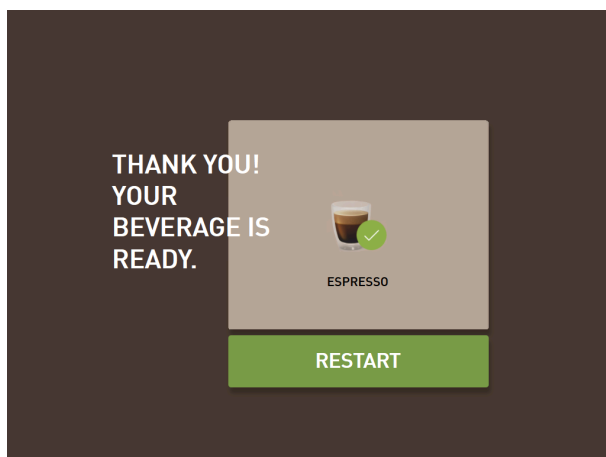

Figure: Display of **Beverage dispensing completed**

- ▶ Remove the cup or mug from the drip tray.
  - ✓ The **Remove cup/mug** animation is shown in the display.

### 8.5.12 Cancelling beverage dispensing

#### Cancelling before beverage dispensing



Figure: **Cancel** button

The  button cancels the pending beverage dispensing process and takes you back to the beverage selection screen.

The button appears while beverage options are being selected. The current selection and any preselected beverage options are then cancelled before the beverage is dispensed.

### Cancelling during beverage dispensing

The **CANCEL** button appears during beverage dispensing.

The **CANCEL** button cancels the beverage dispensing process. Pre-selected beverages are also deleted.

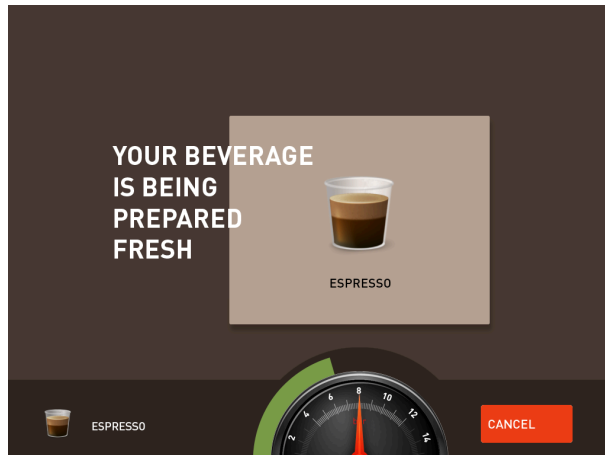

Figure: Guest mode and Frequent user mode: Cancelling beverage dispensing

Guest mode and Frequent user mode: Cancelling beverage dispensing

1. Tap on the **CANCEL** button.
  - ✓ Dispensing of a beverage is stopped.

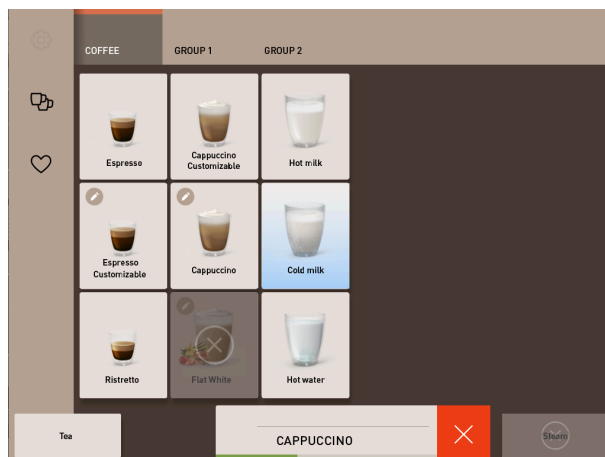

Figure: Staff mode: Cancelling beverage dispensing

### Staff mode: Cancelling beverage dispensing

1. Tap on the **(X)** button.
  - ✓ Dispensing of a beverage is stopped.

## 8.6 Using manual inlet

Ground coffee is available for preparing a beverage using the manual inlet.



The configuration for coffee beverages with ground coffee is available in the beverage settings. Configuration can be carried out by service technicians.

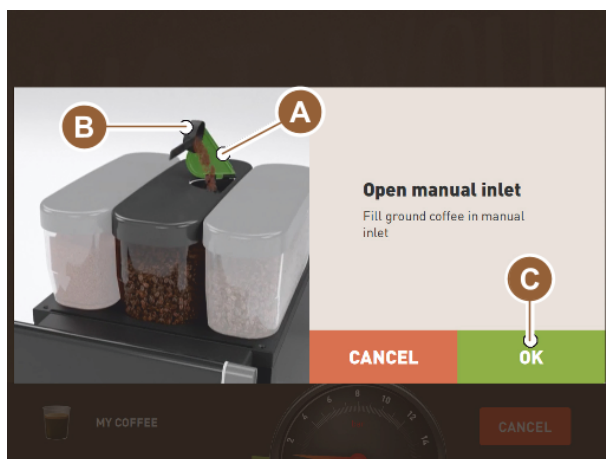

Figure: Filling ground coffee request

1. Select a beverage group with beverage options on the user interface.
2. Select a beverage with the option for pre-ground coffee, e.g. decaf.
3. If necessary, select the other dispensing options, such as small, medium or large.
4. Start the dispensing process.
  - ✓ An animation instructing you to insert ground coffee appears.
5. Open the cover **(A)** of the manual inlet.
6. Pour a portion of ground coffee into the opening of the manual inlet using the measuring spoon **(B)** provided.
7. Confirm this with **OK (C)**.
  - ✓ Beverage dispensing starts.

## 8.7 Generic functions of the user interface

### 8.7.1 Navigation in the interface

In **Guest mode** or **Frequent user mode**, you can navigate by **swiping** left or right across the screen. You can also use the arrow buttons to **scroll** through all beverage groups.



Figure: Navigation in Guest mode with arrow buttons

- The **arrow <** button navigates to the left to the previous beverage group.
- The **arrow >** button navigates to the right to the next beverage group.

The number of dots corresponds to the number of beverage groups available.

In **Staff mode**, you navigate by **swiping** across the beverage groups at the top of the screen.





Figure: Tabs in Staff mode

- Tapping on a tab directly selects a beverage group.
- Swiping to the left or right on the tabs navigates to the previous or next beverage group.

The number of tabs (beverage groups) is not fully visible.

Figure: **Back** buttonFigure: **Next** button

The  button takes you back to the previous screen. The  button leads you to the next screen.

## 8.7.2 Display of beverages

### Type of display

The type of display for the beverages on the user interface depends on the operating mode.

The beverage buttons can be individually named and assigned via media packages at the request of the customer.

The configuration of the display is carried out by service technicians.



Figure: Types of display of the beverage buttons

- A** Default (display with glass)      **B** Cup (display with cup)

Each beverage button can be individually assigned a beverage. The beverage button starts the corresponding beverage dispensing process or preselection for additional ingredients and beverage options.

### Size of display

The display size of the beverages is defined in the **Menu card** configuration.



Figure: Small and extra large beverage display

Available display sizes:

- Small
- Medium
- Large
- Extra large
- Dynamic

## 8.7.3 Pending error message or instruction for action

Error messages are displayed at the top or bottom of the user interface. If an error message is active, intervention by the user or a service technician is required.



Figure: Service button with error display

1. Tap on the error message display.

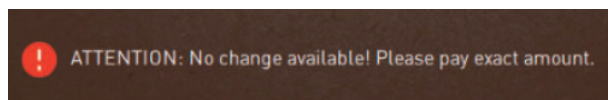

- ✓ The Service menu is displayed.
2. Select the pending error message with the **(>)** button in the Service menu.
    - ✓ The **Smart info** window with additional information appears.

## 8.7.4 Error messages (simple)

Error messages or requests are shown in the display corresponding to the set operating mode.

In Guest mode, the default setting for error messages is **simple**.

Service technicians can change the setting to **specific error messages**.

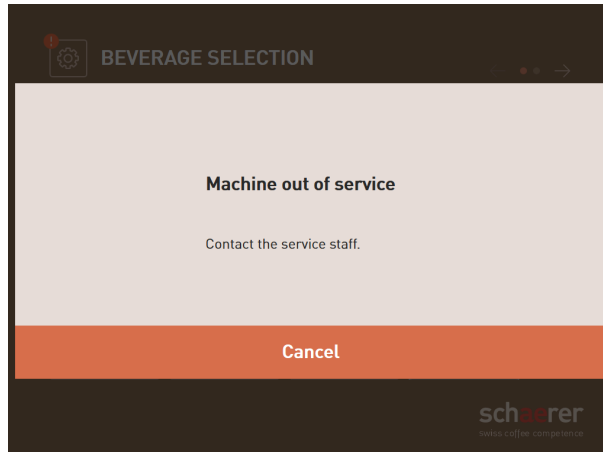

Figure: Simple error message

Simple error messages show the following information:

- The machine is no longer ready for use.
- The **Inform service staff** instruction is displayed.

## 8.7.5 Error messages (specific)

Error messages or requests are shown in the display corresponding to the set operating mode.

In Staff or Frequent user mode, the default setting for error messages is **specific**.

Service technicians can change the setting to a **simple error message**.

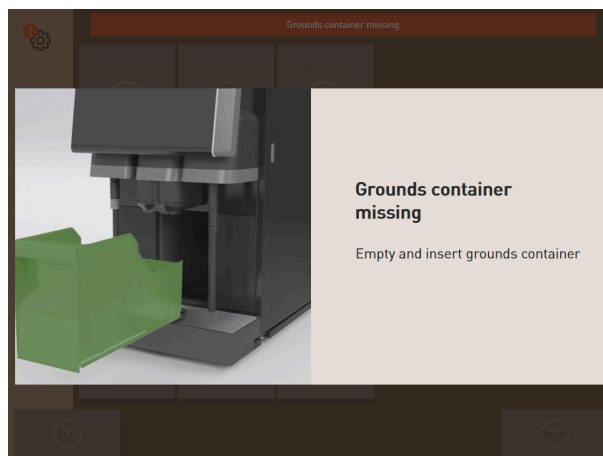

Figure: Specific error message

Specific error messages show the following information:

- Action requests or errors are displayed directly.
- The machine can be independently restored to the ready for use condition if necessary.

## 8.8 Service menu

### 8.8.1 Service menu button

The **Service menu** button may be displayed differently depending on the operating mode.



Figure: **Service menu** button in Guest mode



Figure: **Service menu** button in Staff mode and Frequent user mode

The **Service menu** button has two functions.

- Control function: The Service menu is opened with the **Service menu** button.
- Reporting function: Additional information with colour coding

**Control function for opening the Service menu:**

- ▶ Tap on the **Service menu** button.
- ✓ The **Service menu** screen opens.

**Reporting function: Additional information with colour coding**

In the user interface, the **Service menu** button provides information about pending information or error messages.

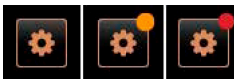

Figure: **Service menu** button with messages

- **Without colour code:** There are no messages in the Service menu.
- **Orange:** There is information in the Service menu.
- **Red:** There are error messages or action requests in the Service menu.

## 8.8.2 Service menu overview

Access to the Service menu in the **Machine operator** profile can be protected by a service technician with a PIN as an option.

**Functions in the Service menu**

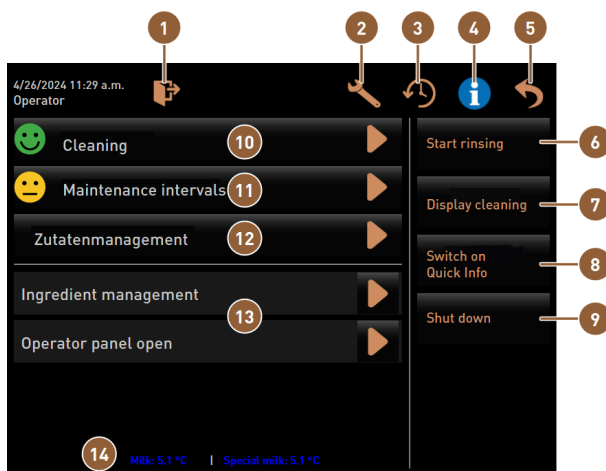



Figure: Functions in the Service menu

- |   |  |    |  |
|---|--|----|--|
| 1 | Logs out the currently registered profile or opens the log-in dialogue for logging in with different profiles. | 8  | Direct selection: Displays a quick info message.   |
| 2 | Opens the screen with the machine settings.  | 9  | Direct selection: Switches the machine off.  |
| 3 | Shows the dialogue with the beverage dispensing history and the list of dispensed beverages.                   | 10 | Displays the cleaning status and opens the screen for performing cleaning.   |
| 4 | Shows the dialogue with system information including QR code.  | 11 | Displays the maintenance status and opens the screen for carrying out maintenance.                                   |
| 5 | Closes the screen with the Service menu and takes you back to the user interface.                              | 12 | Opens the screen for ingredient management.  |
| 6 | Direct selection: Starts rinsing process.  | 13 | Displays pending messages and opens the dialogue with the respective instruction for action and its acknowledgement. |
| 7 | Direct selection: Locks the screen for 30 s for screen cleaning.   | 14 | Optional: Displays the milk temperature.   |

#### General buttons in the Service menu

- Use the **Confirm**  button to start pending actions or confirm displayed instructions for action.
- The **Next**  button takes you step to step through the display-guided action steps for cleaning, descaling or grinder service.



If an error occurs during a restart, the screen with the Service menu is displayed immediately.

### 8.8.3 Quick info

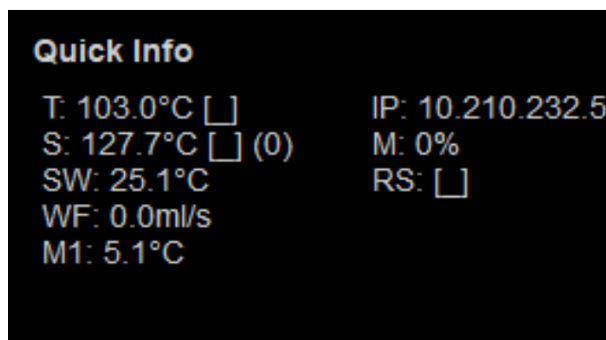

Figure: Quick info

The **Quick info** appears on the Service menu screen and provides information on the following parameter values:

- **T** displays the hot water boiler temperature in °C.
- **S** displays the steam boiler temperature in °C.
- **SW** displays the steam wand temperature in °C.
- **WF** displays the required water quantity in ml/s.
- **M1** displays the current milk temperature.
- **IP** displays the address of the network adapter.
- **M** displays the available storage space in %.
- **RS** informs about the density of beverage supply (Rush hour mode):
  - Rush hour mode is activated if more than 30 beverages are dispensed per hour.
  - When active, rinsing of the beverage outlet is suppressed.
  - The active mode is indicated by **RS[\*]**.

## 8.8.4 Profiles (log in / log out)

Access rights to functions and parameters depend on the profile.



See 11 "Programming" for a more detailed overview and description of the profiles.

### 8.8.4.1 Access variant to the Service menu without PIN entry

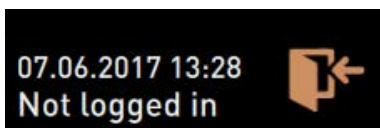



Figure: No profile is logged in.

- ▶ Tap on the **Service menu**  button in the user interface.
  - ✓ The Service menu opens with the last activated user profile or without an active profile (not logged in).

### 8.8.4.2 Variant: Access to the Service menu with PIN entry



Every profile has specific authorisations. Logging in with a profile can be protected with a PIN. Service technicians can activate and deactivate profiles, define a PIN and assign it to a profile.

Prerequisite: Access to the Service menu is protected by a PIN.

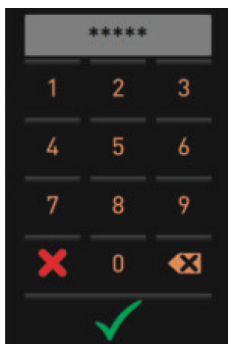

Figure: Numeric keypad for PIN entry

1. Tap on the **Service menu**  button in the user interface.
  - ✓ The numeric keypad for PIN entry appears.



Figure: No profile is logged in.

2. Enter the configured PIN and confirm.
  - ✓ The screen with the Service menu opens without an active user profile.
  - ✓ All direct dial functions with the exception of **Free vending** are available for selection.
  - ✓ **Info – Show versions** is available in the settings.

## 8.8.4.3 Access to the Profiles dialogue



When the Service menu is closed, the currently logged in profile remains active.  
The active profile is only logged out after logging out using the button or after a restart.

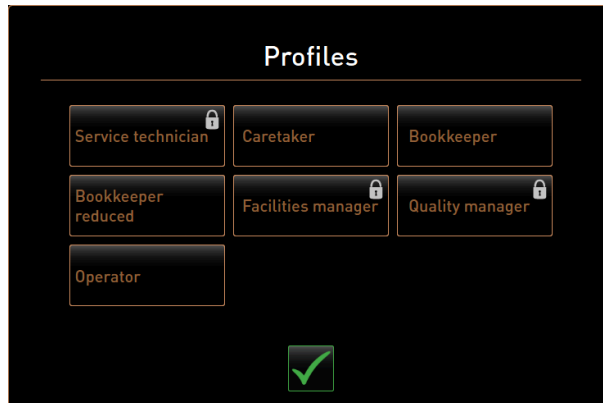



Figure: **Profiles** dialogue

- ▶ Tap on the **Log-in**  button in the Service menu.
  - ✓ The **Profiles** dialogue opens with the profiles configured by service technicians.
  - ✓ Profiles protected with a PIN are marked with a lock symbol.

The following profiles can be enabled by service technicians:

- Caretaker
- Bookkeeper
- Bookkeeper reduced
- Facilities manager
- Quality manager
- Machine operator

## 8.8.4.4 Variant: Activating unprotected profile

- ▶ Select the desired unprotected profile, e.g. **Caretaker**.
  - ✓ The Service menu is displayed with the active **Caretaker** profile.
  - ✓ The functions available in the Service menu correspond to the selected profile.



See 11.3 "Profiles and authorisations" for detailed information on the functions of the individual profiles.

## 8.8.4.5 Variant: Activating protected profile

Prerequisite: The profile is protected by a PIN and is marked with a lock symbol.

1. Select the desired protected profile, e.g. **Service technician**.
  - ✓ The numeric keypad for PIN entry opens.

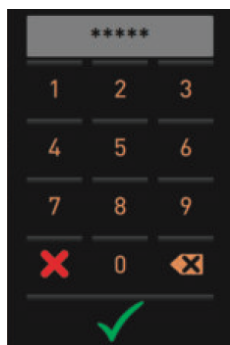

Figure: Numeric keypad for PIN entry

2. Enter the configured PIN and confirm with .
  - ✓ The Service menu is displayed with the selected profile.



See 11.3 "Profiles and authorisations" for detailed information on the specific functions.

#### 8.8.4.6 Profile log-out

1. Tap on the **Log-out** button in the Service menu.
  - ✓ The active profile is logged out.
  - ✓ Any authorisations become invalid.



Figure: No profile is logged in.

- ✓ **Not logged in** is displayed in the Service menu.

### 8.8.5 Scope of functions

#### Cleaning

PIN-protected function (caretaker, operator, service technician)

- ▶ Tap on the **Cleaning** button.
  - ✓ The display-guided cleaning process starts.
  - ✓ Cancelling is possible with the button.
  - ✓ The last executed cleaning process is displayed.

#### Maintenance



In general, a green smiley indicates that cleaning or maintenance has been completed. A red smiley indicates that cleaning or maintenance is pending.



Figure: Maintenance overdue

PIN-protected function (caretaker, operator, service technician)

1. Execute the displayed maintenance work.

2. Tap on the **Maintenance** button.
  - ✓ Cancelling is possible with the  button.
3. Acknowledge the maintenance work.
  - ✓ The acknowledged maintenance process is indicated with the date and a green smiley.

### Ingredient management

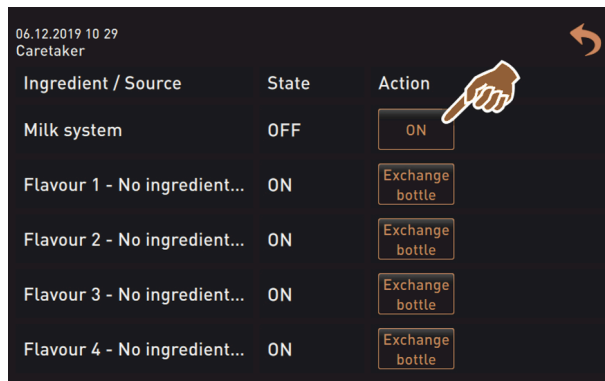



Figure: Enabling ingredient

#### Variant: Enabling ingredient

1. Tap on the **Ingredient management** button.
  - ✓ The screen with the active ingredients opens.
2. Tap on the **ON** button in the **Action** column.
  - ✓ The ingredient is enabled.
3. Tap on  to return to the Service menu.

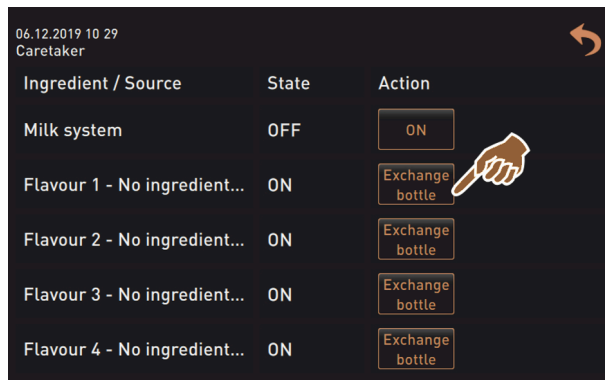



Figure: Bottle change

#### Variant: Syrup bottle change

1. Tap on the **Ingredient management** button.
  - ✓ The screen with the active ingredients opens.
2. Tap on the **Bottle change** button for syrup types 1 to 4 in the **Action** column.
  - ✓ The **Bottle change** screen shows the display-guided steps.
  - ✓ The previously selected syrup hose is drained.
3. Remove the bayonet lock from the empty bottle at the Flavour Point and thoroughly clean the hose with the bottle adapter.
4. Confirm the cleaning process with .
5. Insert the bottle adapter with the cleaned hose into the new syrup bottle.
6. Reconnect the bayonet lock back to the Flavour Point.

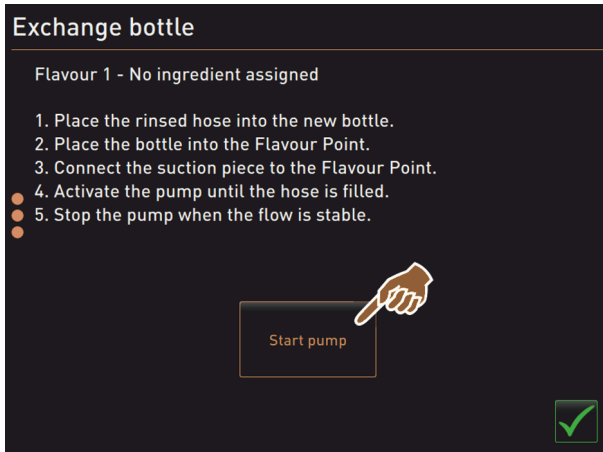

Figure: Starting pump

1. Tap on the **Start pump** button and then the **Stop pump** button to refill the hose.
2. Confirm the hose filling with .
  - ✓ The **Bottle change** screen closes and the user interface is displayed.

### Error message or action request

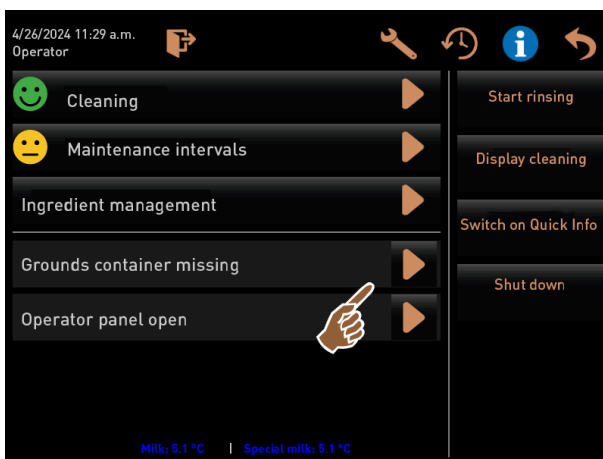

Figure: Opening error message

1. Press to open the pending message.
  - ✓ The pending message appears in a separate window.
2. Correct the pending error or carry out the required action.
  - ✓ The error message or the action request is automatically deleted from the list.
  - ✓ Service technicians can see an overview of events in the **Info > Error statistics** main menu.

### Back to user interface

The button takes you back to the user interface.

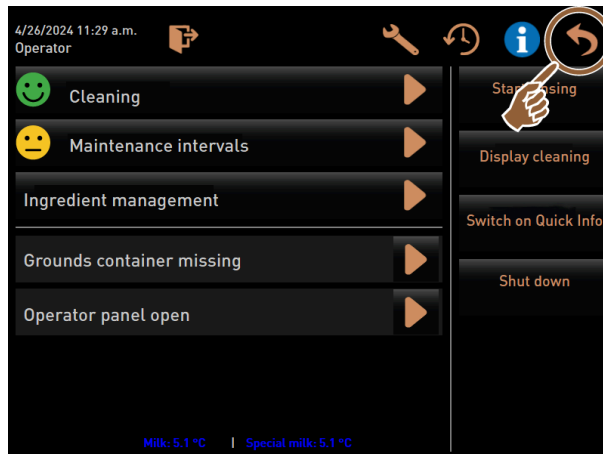



Figure: Back to user interface

- ▶ Tap on .
  - ✓ The user interface appears.
  - ✓ The registered profile is logged out.

### System information



Figure: Calling up system information

- ▶ Tap on .
  - ✓ The system information is displayed in a separate window.
  - ✓ A QR code with system information is also displayed.

## Beverage dispensing history

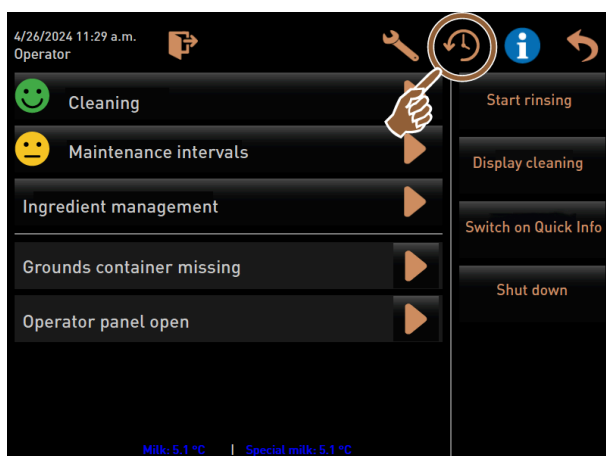

Figure: Calling up beverage dispensing

▶ Tap on .

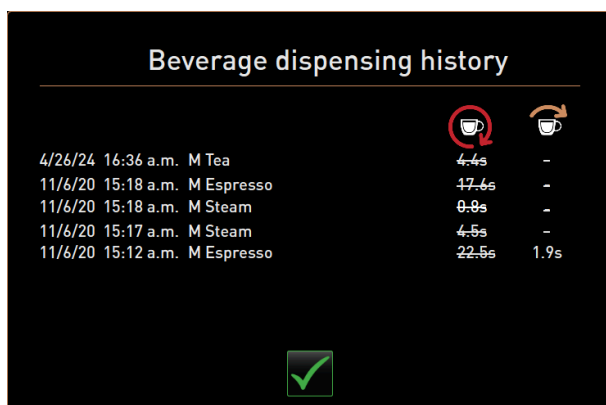

Figure: **Beverage dispensing history** dialogue

- ✓ The **Beverage dispensing history** dialogue opens and all beverages already dispensed are shown in a list.
- ✓ The corresponding beverage dispensing duration is also displayed for each dispensed beverage.
- ✓ The pure beverage dispensing time (coffee) is shown on the right side of the list.

The pure dispensing time for should be 10 to 15 s for single coffee beverages and approx. 20 to 25 s for double beverages. However, this is only a reference value and can vary due to the grind quantity, grinding level, water temperature and coffee type.

## Settings

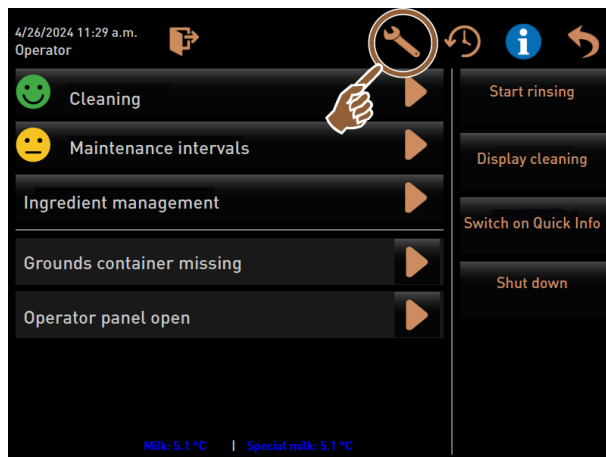



Figure: Calling up settings

- ▶ Tap on .
  - ✓ The settings are displayed.
  - ✓ These make the parameter settings available.



The access authorisation for parameter settings depends on the registered profile.



See 11 "Programming" for a detailed description.

## Log-in/Log-out

The function is used to log in and select a profile.

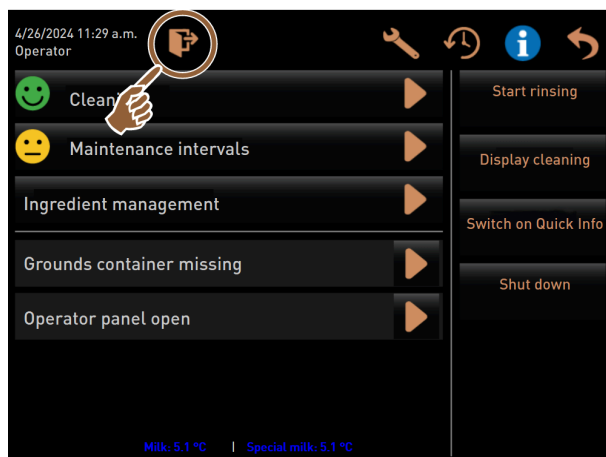



Figure: Log-in/Log-out

- ▶ Tap on .
  - ✓ The window for selecting a profile appears.



See 8.8.4 "Profiles (log in / log out)" for a detailed description.

### “Start rinsing” direct selection

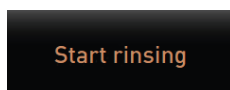

Figure: **Start rinsing** button

- ▶ Tap on the **Start rinsing** button.
  - ✓ Hot rinsing for the all systems (coffee system, milk system and powder system) is performed.
  - ✓ The rinsing process cannot be cancelled.



See 9 “Cleaning”

### “Touch screen cleaning” direct selection

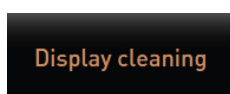

Figure: **Touch screen cleaning** button

- ▶ Tap on the **Touch screen cleaning** button.
  - ✓ The display remains insensitive for a period of 30 s and can be cleaned.

### “Switch on quick info” direct selection

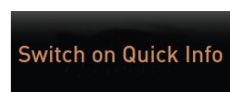

Figure: **Switch on quick info** button

- ▶ Tap on the **Switch on quick info** button.
  - ✓ The quick info window with the operating statuses appears floating in the foreground.

### “Activate free vending” direct selection (with payment system)

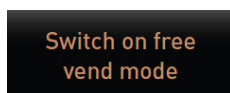

Figure: Activating Free vending mode

- ▶ Tap on the **Activate free vending** button.
  - ✓ Chargeable beverages are made available for free vending.
  - ✓ The **Activate free vending** button is accessible to service technicians, bookkeepers and caretakers.

### “Switch-off” direct selection

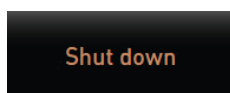

Figure: Switch-off

- ▶ Tap on the **Switch-off** button.
  - ✓ The machine is shut down.
  - ✓ The machine is shut down but not de-energised.
  - ✓ The display does not show anything and is inactive.

## 8.9 Emptying

### 8.9.1 Emptying grounds container

#### ADVICE

#### Material damage due to possible overfilling of the under-counter grounds container!

The under-counter grounds container is not monitored. There is a risk of overfilling. During emptying, beverage selection is possible even without the under-counter grounds container.

- ▶ Check the under-counter grounds container according to machine usage.
- ▶ Make sure that no beverages are dispensed while the under-counter ground container is being drained.



**Standard grounds container:** The grounds container can hold about 60 – 70 coffee cakes. After this number has been reached, the request for emptying the grounds container appears in the user interface.



Figure: Standard grounds container

#### Standard grounds container

1. Push the manual beverage outlet upwards as far as it will go.
2. Pull the grounds container forward out of the machine.
  - ✓ The **Grounds container removed** message appears on the display.
3. Empty and clean the grounds container.
4. Dry the grounds container and reinsert it into the cooling unit up to the stop.
  - ✓ The machine is ready for use.

#### Integrated grounds container

1. Push the manual beverage outlet upwards as far as it will go.
2. Pull the integrated grounds container out halfway.
  - ✓ This prevents accidental beverage dispensing.
3. Empty and clean the under-counter grounds container.
4. Place the under-counter grounds container back under the grounds chute of the machine.
5. Push the integrated grounds container back in as far as it will go.
  - ✓ The machine is ready for use.

## 8.9.2 Emptying external waste water tank



### ADVICE

#### Level monitoring

The external drinking water and waste water tanks feature integrated level monitoring.

- ▶ Check the mechanical function of the floater for level monitoring every time the tanks are emptied.
- ▶ Ensure that no beverages can be dispensed before the waste water tank is removed.



The machine features a waste water outlet. The drip tray is fixed and cannot be removed.



See 6.3.2 "Connecting water supply"

Prerequisite: The machine is ready for beverage dispensing.



Figure: External waste water tank

1. Push the manual beverage outlet upwards as far as it will go.
2. Pull the grounds container forward out of the machine.
  - ✓ The **Grounds container removed** message appears on the display.
3. Remove the cover with waste water hose from the external waste water tank.
4. Remove the waste water tank.
5. Clean the waste water tank thoroughly with household cleaner.
6. Check the function of the level monitoring floater.
7. Insert the cover with waste water hose back into the tank.
  - ✓ The machine is ready for beverage dispensing.
8. Reinsert the grounds container into the cooling unit.

## 8.10 Switch-off

### 8.10.1 Switching machine to standby



**DANGER**

#### Risk of death due to electrocution!



The machine is still energised in Standby mode.

- ▶ Do not remove any machine housings.
- ▶ Always unplug the machine from the mains before doing repair work.

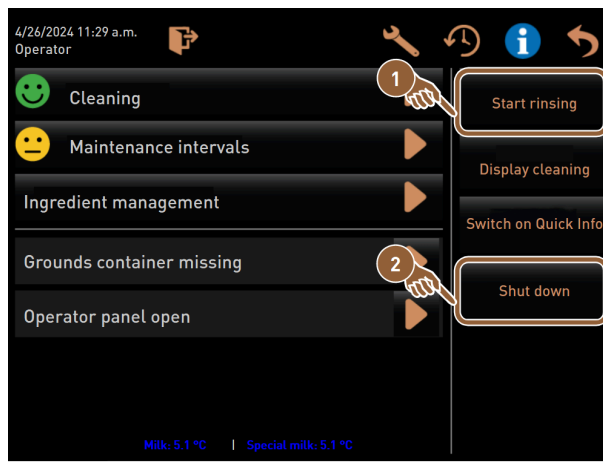

Figure: Switch-off using touch screen

- 1** Start rinsing
- 2** Switch-off

1. Start machine cleaning **(1)** in the Service menu.
  - ✓ Cleaning is started.
2. Carry out daily and weekly cleaning as required.
3. If present, empty and clean the external drinking water tank.



See 9 "Cleaning"

After automatic cleaning, the machine can be switched off directly from the cleaning program.

#### Variant: Switch-off using touch screen

- ▶ Tap on the **Switch-off (2)** button in the Service menu.
  - ✓ The machine is shut down.
  - ✓ The display does not show anything.
  - ✓ The machine is in "Standby mode".

**Variant: Switch-off using button****DANGER****Risk of death due to electrocution!**

Even when the machine is shut down, there are live parts present in the machine.

- ▶ Do not remove any machine housings.
- ▶ Always unplug the machine from the mains before doing repair work.

Shutting down the machine can also be done using the power button behind the user panel.



Failure to do so will result in a loss of warranty coverage in the event of damage.



See 8.2.2 "Switching on machine"

**8.10.2 Lengthy downtimes (more than 1 week)****ADVICE****Material damage due to frozen water!**

The boilers can be damaged by freezing water as it expands.

- ▶ If the machine is exposed to below-freezing temperatures, empty the boiler(s) beforehand.
- ▶ Contact your service partner.



During longer downtimes, for instance company holidays, take the machine and other associated devices out of operation.

When restarting the machine, first perform a daily cleaning.

- ▶ Disconnect the mains connection by pulling out the mains plug or switching off a main switch installed at the installation site.
  - ✓ The machine is de-energised.

**8.10.3 Switching off optional accessories****CAUTION****Damage to property and health problems due to pollution!**

If the optional accessories are not cleaned, they may cause technical malfunctions and health problems when they are switched on again.

- ▶ Clean the machine before optional accessories that come into contact with milk are switched off.
- ▶ Disconnect the machine from the mains if the optional accessories are to remain switched off for a longer period of time.
- ▶ Accessory parts such as milk container, cover and adapter must be stored in a clean and dry place.

1. Drain the milk container into optional accessories which transport milk.
2. Clean the machine daily.

3. Clean accessory parts such as milk container, cover and adapter in a washing machine or rinse them thoroughly with fresh, clean water.
4. Switch off the optional accessory using the main switch.
5. Keep the accessory parts in a clean and dry place.
6. Disconnect the mains connection by pulling out the mains plug.
  - ✓ The optional accessory is powered off.
  - ✓ The optional accessory can be stored over a long period of time.

## 9 Cleaning

Cleaning is a prerequisite for safe and trouble-free operation. That is why it is of the utmost importance and must be carried out in accordance with the regulations described.

### 9.1 Cleaning requirements and conditions

**HACCP cleaning concept: HACCP** stands for **Hazard Analysis Critical Control Point**.

The HACCP cleaning concept is designed to ensure safe food. Hazards related to the processing of food or emanating from finished products are considered and the risks are assessed. The risks are mitigated by appropriate measures.

When installation, maintenance, care and cleaning are performed properly, Schaefer AG machines and devices satisfy the HACCP requirements.

All cleaning products are perfectly matched to the cleaning programmes.



#### WARNING

##### Risk of infection from bacteria!



If the coffee machine is not cared for and cleaned properly, the dispensing of beverages will become a health hazard in terms of food hygiene.

- ▶ Wear protective gloves when cleaning.
- ▶ Wash your hands thoroughly before and after handling cleaning products.
- ▶ Clean the machine daily.
- ▶ Clean the milk container every time before filling and after you have finished dispensing for the day.
- ▶ Never add cleaning products to the milk container; always use the blue cleaning container.
- ▶ Never pour cleaning products into the drinking water tank (internal/external).
- ▶ Never mix cleaning products.
- ▶ Store cleaning products separately from coffee, milk and coffee machine powder.
- ▶ Do not use any abrasive products, brushes or cleaning tools made of metal.
- ▶ Do not touch any parts that come into contact with beverages after cleaning.
- ▶ Observe the dosing and safety notes on the cleaning product and follow them.

### 9.2 Cleaning products



#### DANGER

##### Danger of poisoning from cleaning products!



Cleaning products can lead to poisoning if not used properly.

- ▶ Only use cleaning products recommended by Schaefer.
- ▶ Keep cleaning products away from children.
- ▶ Do not touch the cleaning products with your bare hands and do not ingest them.
- ▶ Never add cleaning products to the milk container; always use the blue cleaning container.
- ▶ Before using a cleaning product, read the information on the packaging and the safety data sheet carefully. If a safety data sheet is not available, please request it from your sales partner.



**ADVICE**

**Property damage due to incorrect cleaning products!**

Use of incorrect cleaning products may damage the machine.

- ▶ Use only cleaning products for daily and weekly cleaning that are recommended by Schaeerer AG.

**Cleaning tabs for coffee system**



Name	Coffeepure tabs
Application	Coffee system cleaning
Purpose of cleaning	Removal of grease residue in the coffee system
Application interval	Once a day
Application	Instruction to add a tab during display-guided cleaning

**Cleaning powder for milk system**



Name	Milkpure powder
Application	Milk system cleaning
Purpose of cleaning	Removal of milk fat and bacteria from the milk system
Application interval	Once a day Allocation of cleaning bags: <ul style="list-style-type: none"> <li>• 4x alkaline = green = Cleaner 1</li> <li>• 1x acid = red = Cleaner 2</li> </ul> <p>For daily cleaning, perform four intervals with <b>Cleaner 1</b> and the fifth interval with <b>Cleaner 2</b>.</p>
Application	Instruction to add cleaning powder during display-guided cleaning

## Cleaning product reorder



Name	Reordering set
Application	Coffee and milk system cleaning
Article number	075350
Contents	<ul style="list-style-type: none"> <li>• One package of cleaning tabs for the <b>Coffeepure tabs</b> coffee system</li> <li>• Two packages of cleaning powder for the <b>Milkpure powder</b> milk system</li> </ul>
Quantity	<p>Cleaning products for 100 daily cleaning operations:</p> <ul style="list-style-type: none"> <li>• 100x cleaning tabs</li> <li>• 80x <b>Cleaner 1</b> cleaning powder (green)</li> <li>• 20x <b>Cleaner 2</b> cleaning powder (red)</li> </ul>

## 9.3 Cleaning levels

The following cleaning levels are possible:

- None
- Instruction
- Mandatory
- Automatic (with ProCare)



### ADVICE

#### Adjustment of the cleaning level

The cleaning level of a cleaning operation can only be adjusted by service technicians.

#### Variant: None

- Information is not provided about pending cleaning.
- The **Service menu** button does not indicate pending cleaning operations with coloured marking.
- The **Cleaning** button in the Service menu does not indicate any pending cleaning with a red smiley.
- The cleaning operations are started manually in the Service menu.

#### Variant: Instruction



- Information is provided about pending cleaning.
- An orange coloured marking is displayed on the **Service menu** button when a cleaning is pending.
- The duration until the next cleaning is due is displayed in the Service menu in hours.
- The **Cleaning** button in the Service menu shows a red smiley 😞 when cleaning is due.

#### Variant: Mandatory



When mandatory cleaning is active, a pending cleaning operation cannot be put off. The pending cleaning operation does not allow further beverage dispensing.

Not until the cleaning programme is run is the machine ready for use again.

Mandatory cleaning and the period that elapses before it is enforced can be defined in the cleaning schedule by a service technician.

- Information is provided about pending cleaning.
- An red coloured marking is displayed on the **Service menu** button when a cleaning is pending.
- The duration until the next cleaning is due is displayed in the Service menu in hours.
- The **Cleaning** button in the Service menu shows a red smiley ☹️ when cleaning is due.

#### Variant: Automatic (with ProCare)

- The screen with the cleaning sequence opens automatically at the start time.
- Cleaning is performed automatically according to schedule without intervention from the operator.
- Cleaning of the connection piece for the milk hose (Plug & Clean) can be carried out separately.

#### Cleaning time window

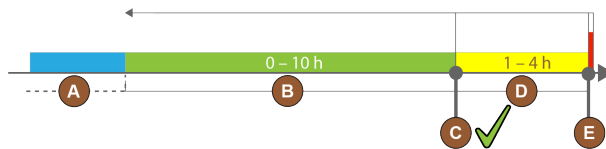

Figure: Time window for cleaning

Item	Time window	Explanation
A	Cleaning operations performed during this time window will be ignored.	The cleaning instructions remain unchanged after a cleaning operation.
B	Cleaning operations performed during this time window are too early. Nevertheless, these cleaning operations are recognised as having been carried out.	The cleaning instructions are reset after a cleaning operation. The next cleaning operation pending in the cleaning schedule is displayed in <b>h</b> in the Service menu.
C	Time for the optimal start of a cleaning (according to schedule).	The remaining time until the optimum start time is displayed in the Service menu.
D	Time window for optimum cleaning on schedule.	The cleaning instructions are reset after a cleaning operation.
E	Time window for mandatory cleaning Overdue cleaning operations cannot be delayed any longer from this time.	The display shows that dispensing is no longer possible. The machine is no longer ready for use. Cleaning is mandatory.

## 9.4 Cleaning intervals

The following sections describe the cleaning intervals required for optimal and trouble-free operation. If increased contamination is detected during regular checks, shortening the required cleaning intervals according to the actual contamination symptoms is essential.



## ADVICE

**Cleaning with high beverage volume**

If the daily volume of beverages exceeds the reference value of 200-250 beverages, two daily cleaning operations are recommended.

Daily	Weekly	As needed	Optiona	
Automatic cleaning				
x				Automatic rinsing (if programmed)
x		x		Hot rinsing
x		x		Milk hose rinsing
Cleaning programme				
x		x	0	Milk system cleaning (after request)
x		x		Coffee system cleaning (after instruction)
		x	0	Flavour Point (syrup system)
x		x	0	Rinsing of mixing cup with manual cleaning process
x	x		0	Steam boiler rinsing
Manual cleaning work				
x				Emptying grounds container and cleaning
x				Brewing chamber
x				Cleaning drip tray and drip grid
x			0	Rinsing milk container
x			0	Cooling unit interior
x				Cleaning touch screen
x		x	0	Steam wand
x			0	Rinsing of external drinking water tank
x			0	Rinsing of external waste water tank
			0	Cleaning optional accessories
	x	x		Cleaning bean hoppers
		x		Lower beverage outlet part
		x	0	Rinsing powder container
		x	0	Defrosting of cooling unit
		x		Cleaning outer surfaces

Daily	Weekly	As needed	Optiona	
		x	0	Cooling unit outer surfaces

#### Legend of cleaning intervals

Daily	At least once a day, or more often if necessary
Weekly	At least once a week, or more often if necessary
As needed	If there is any contamination

## 9.5 Machine rinsing



### CAUTION

#### Scalding danger due to hot water!

While the machine is being rinsed, hot water runs out of the beverage outlet. An automatic machine rinse is announced by a message on the display. The functional lighting turns red.

- ▶ Do not reach under a beverage outlet while a machine is being rinsed.
- ▶ Align the optional steam wand in the drip tray.
- ▶ Configured rinsing processes are automatically restarted. That is why you have to make sure that the beverage outlet is always free.

### 9.5.1 Automatic switch on/off rinsing



The automatic switch on/off rinsing process is the standard setting and cannot be disabled.

The following systems are automatically rinsed after switching on or before shutting down (if present):

- Coffee system
- Milk system
- Powder system
- Hot & cold system (option)

### 9.5.2 Configured rinsing processes



The configured rinsing processes are activated once an hour in the standard setting.

In addition to on/off rinsing, service technicians can set rinsing processes for the following systems in the Service menu:

- Rinsing > Beverage outlet (rinsing interval outlet) (1 – 180 min)
- Rinsing > Milk system (rinsing interval of external milk hose) (1 – 180 min)
- Rinsing > Milk system (rinsing interval of internal milk system) (1 – 180 min)
- Rinsing > Reverse flow cooler (rinsing interval of heat exchanger) (1 – 180 min)

### 9.5.3 Manual rinsing processes (service menu)

Additional rinsing processes can be activated manually at any time in the Service menu.

- ▶ Tap on the **Service menu**  button.
  - ✓ The Service menu opens.

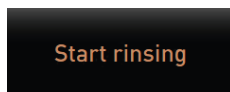

Figure: **Start rinsing** button

- ▶ Tap on the **Start rinsing** button.
  - ✓ A system rinsing is executed in the same sequence as the automatic switch on/off rinsing.



See 9.5.1 "Automatic switch on/off rinsing"

## 9.6 Display-guided cleaning

With display-guided cleaning, all pending activities are shown on the screen using animations and instructions are displayed in text form.

The completed action steps must be confirmed on the screen in order to proceed to the next step.



#### WARNING

##### **Danger to health from contamination!**



- Contamination of cleaned machine components by cleaning products can lead to health problems.
- ▶ Wear protective gloves during the cleaning programme.



#### CAUTION

##### **Scalding danger due to hot fluids!**

Hot fluid will be dispensed during the cleaning programme.

- ▶ Remove the drip grid before starting cleaning.
- ▶ Do not reach under the beverage outlet, steam outlet and external hot water dispensing point during cleaning.

#### ADVICE

##### **Material damage due to overflowing drip tray!**

A plugged waste water outlet causes the drip tray to overflow.

- ▶ Check the waste water outlet in the drip tray before starting the cleaning programme.

The display-guided cleaning programs can be divided into **scheduled cleaning** and **additional cleaning**.

### Scheduled cleaning

- The programmes are stored in the PC board of the coffee machine.
- The type and frequency of the cleaning programmes to be carried out is set in the Service menu via a cleaning schedule.
- Service technicians can adjust the cleaning schedule (e.g. change the cleaning level).

### Additional cleaning

- Additional display-guided cleaning processes can be started manually at any time in the Service menu.
- The type and scope of cleaning can be activated or deactivated individually.
- The processes for the activated cleaning type are carried out in the same way as for scheduled cleaning.

If no **ProCare** unit is installed, both scheduled cleaning and additional cleaning are carried out with the **Coffeepure tabs** cleaning tabs and the **Milkpure powder** cleaning powder.

If a ProCare unit is installed, both scheduled cleaning operations and additional cleaning operations are always carried out with **ProCare**.

If a **Flavour Point** module is installed, a separate cleaning programme is offered in the **Cleaning** screen.

## 9.6.1 Required tools

The following utensils are required during the display-guided cleaning programme:

- Schaerer > **Coffeepure tabs** cleaning tab for coffee system (1x tablet)
- Schaerer > cleaning powder for **Milkpure powder** milk system (1x bag)
- Schaerer > cleaning container (milk system) (1x container, blue)
- Commercial detergent
- Clean commercial cleaning cloths
- Collecting vessel for remaining milk (if needed)
- Collecting vessel for remaining choco powder or topping (if needed)
- With the powder system equipment, you must be able to access the area behind the user panel. Keep key to the optionally lockable user panel or open lock in advance.

- ▶ Tap on the **Service menu**  button.
  - ✓ The Service menu opens.



1. Tap on the **Cleaning** button.
  - ✓ The **Cleaning** window opens.

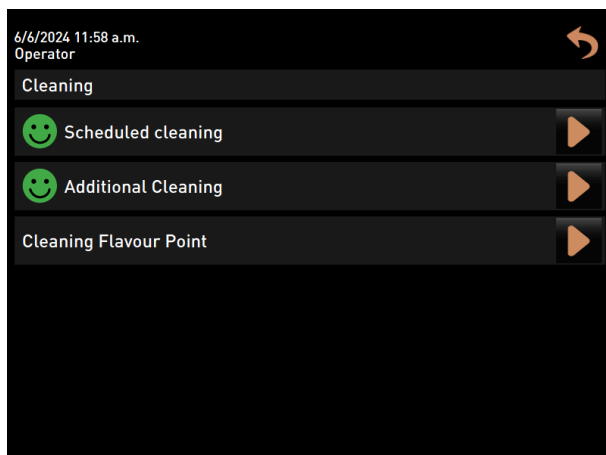

Figure: Screen for selecting the cleaning types

The following cleaning types are possible:

- Scheduled cleaning
- Additional cleaning
- Flavour Point cleaning (optional)

## 9.6.2 Starting scheduled cleaning

The cleaning programme is started in the Service menu. On the touch screen, the user is guided through all required actions.

**Prerequisite:** A pending cleaning is displayed on the **Service menu** button.



Figure: The **Service menu** button with pending cleaning

1. Remove the drip grid for separate cleaning.
2. Tap on the **Service menu**  button.
  - ✓ The Service menu opens.
3. If the cleaning process is PIN-protected, enter the PIN configured for this.
  - ✓ Authorisation is granted.
  - ✓ The **Cleaning** button is active now.



4. Tap on the **Cleaning** button.
  - ✓ The **Cleaning** screen with the menu items for the different cleaning types opens.
5. Tap on the **Scheduled cleaning**  button.

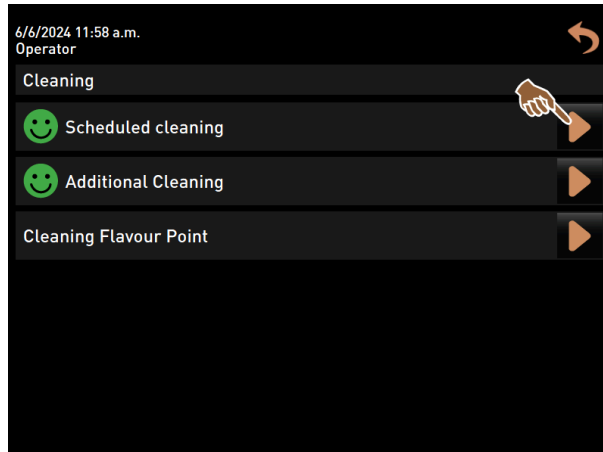

Figure: Opening scheduled cleaning

- ✓ The **Cleaning according to schedule** dialogue opens.

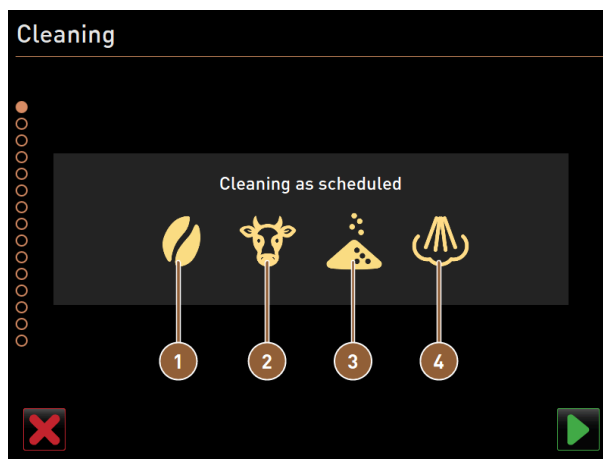



Figure: Dialogue for cleaning according to cleaning schedule

- |   |                               |   |                               |
|---|-------------------------------|---|-------------------------------|
| 1 | Cleaning of the coffee system | 3 | Cleaning of the powder system |
| 2 | Cleaning of the milk system   | 4 | Cleaning of the boiler system |
6. Start the scheduled cleaning with .
    - ✓ Cleaning is started according to the set cleaning schedule.
    - ✓ The systems to be cleaned are highlighted in the dialogue with their icon.

### Display-guided manual cleaning steps

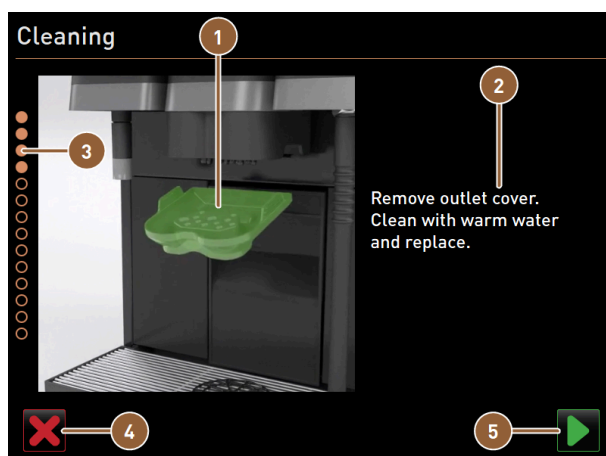



Figure: Start dialogue for cleaning programme

- |   |                                       |   |                                      |
|---|---------------------------------------|---|--------------------------------------|
| 1 | Image or animation for current action | 4 | Button for cancelling cleaning       |
| 2 | Action request or information text    | 5 | <b>Next</b> button for the next step |
| 3 | Progress screen                       |   |                                      |

1. Follow the instructions on the display.
2. After completing the activities shown on the screen, tap on  to go to the next cleaning step.

### Manual cleaning: Grounds container

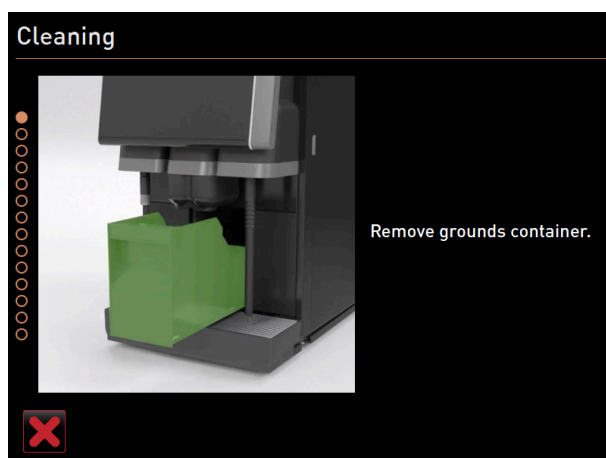

Figure: Removing grounds container

1. Slide the beverage outlet upwards.
2. Pull the grounds container out of the machine.

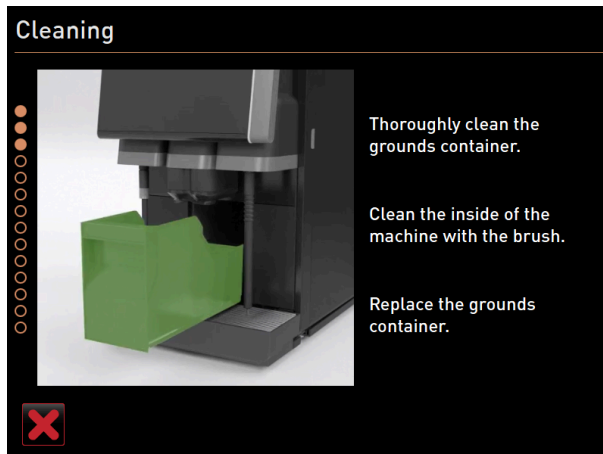

Figure: Replacing the grounds container

- ✓ The instruction to thoroughly clean the grounds container, clean the machine interior with a brush and reinsert the grounds container appears.
3. Wipe any remaining ground coffee out of the brewing chamber with the brush.
  4. Empty the grounds container, rinse it with fresh water and detergent, then dry.
  5. Reinsert the grounds container into the cooling unit up to the stop.

#### Manual cleaning: Beverage outlet cover

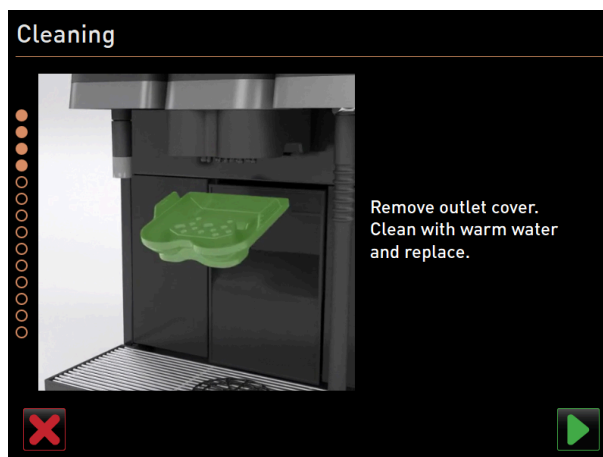



Figure: Removing beverage outlet cover

- ✓ The **Remove beverage outlet cover** instruction appears.
1. Release the beverage outlet cover by pressing it in the centre and pulling it down at the same time.
  2. Clean the beverage outlet cover under warm running water using a brush.
  3. Replace the cleaned cover by clipping the cover into place at the back and snapping it into place at the front.
    - Caution** An incorrectly inserted beverage outlet cover can cause spraying during beverage dispensing.
  4. Check that the beverage outlet cover is correctly positioned.
  5. Confirm with the  button to get to the next step.

### Inserting Coffeepure tab cleaning tablet

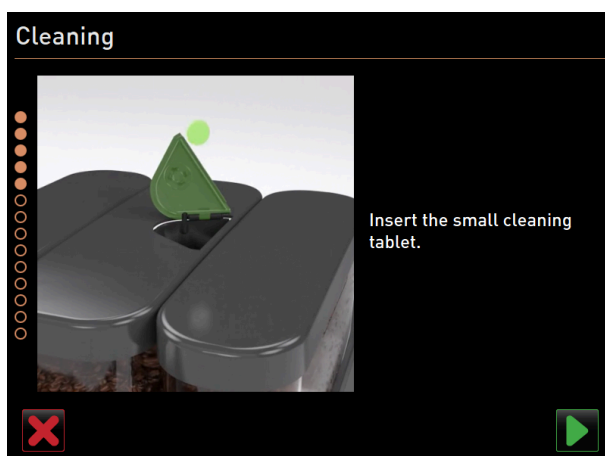

Figure: Inserting cleaning tab

✓ The instruction for inserting the **Coffeepure tab** cleaning tablet appears.

1. Insert the **Coffeepure tab** cleaning tab into the slot of the manual inlet of the centre bean hopper.
2. Confirm insertion with .

### Cleaning milk container (option)



Figure: Cleaning milk container (option)

✓ The **Remove milk container** instruction appears.

1. Open the door of the cooling unit.
2. Remove the milk container(s) from the cooling unit.
3. Pour any remaining milk into other containers if necessary.
4. Clean the milk container, cover and riser pipe with fresh water and detergent and rinse them thoroughly.
5. Confirm with the  button to get to the next step.
  - ✓ The request to place the cleaning powder into the blue cleaning container appears.

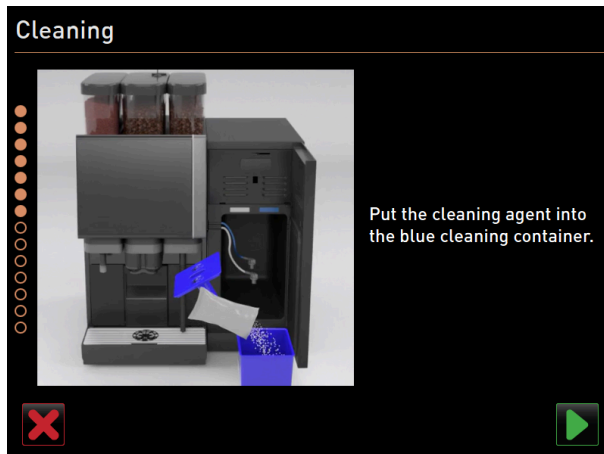



Figure: Pouring cleaning product into cleaning container

Required cleaning product: **Milkpure powder**



Figure: **Milkpure powder** cleaning powder in a bag

6. Pour the contents of one bag of **Milkpure powder** (blue or red according to the order on the packaging) into the cleaning container.
7. Reinsert the blue cleaning container into the cooling unit.
8. Insert the adapter of the milk hose (or milk hoses for **Twin Milk**) into the cover of the cleaning container.
9. Confirm the inserted cleaning container and added Milkpure powder cleaning with .

#### Manual cleaning: Mixing cup (optional)



Figure: Lifting user panel

- ✓ The request to remove the mixing cup (optional) appears.
- 1. Unlock the user panel at the top by pulling it firmly towards you.
  - ✓ The user panel is unlocked.
- 2. Push the user panel from below using both hands until it snaps into place.
  - ✓ The user panel is automatically held in the upper position.
  - ✓ The mixing cup is accessible.

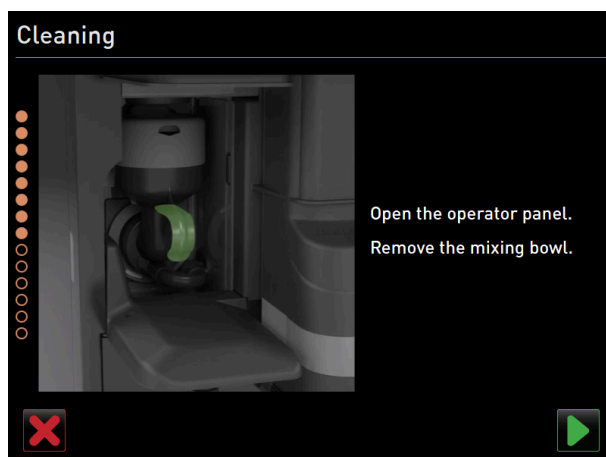

Figure: Pulling out mixing cup



- 3. Pull the mixing cup out of the machine by the recessed grip.
- 4. Confirm removal of the mixing cup with .



Figure: Cleaning mixing cup

- 5. Clean and rinse the individual parts of the mixing cup under clean, warm water.
- 6. Wipe the mixing cup dry with a clean cloth.
- 7. Confirm cleaning of the mixing cup with .

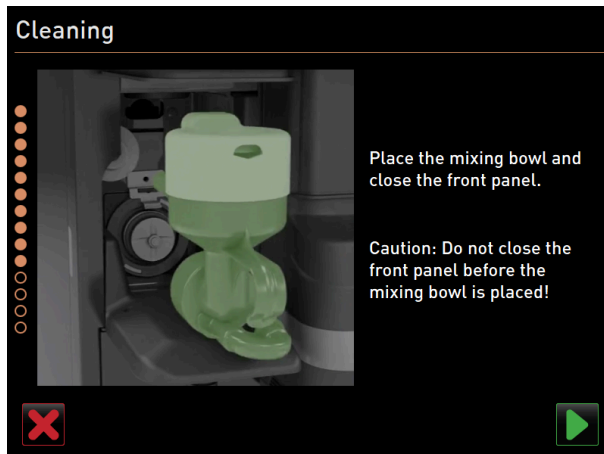



Figure: Inserting mixing cup

8. Reinsert the mixing cup.
  9. Check that the mixing cup is correctly positioned.
  - Caution** An incorrectly inserted mixing cup can lead to overflowing.
  10. Close the user panel.
  11. Confirm cleaning and insertion of the mixing cup with .
- ✓ The cleaning process starts.

#### Progress screen for automatic cleaning

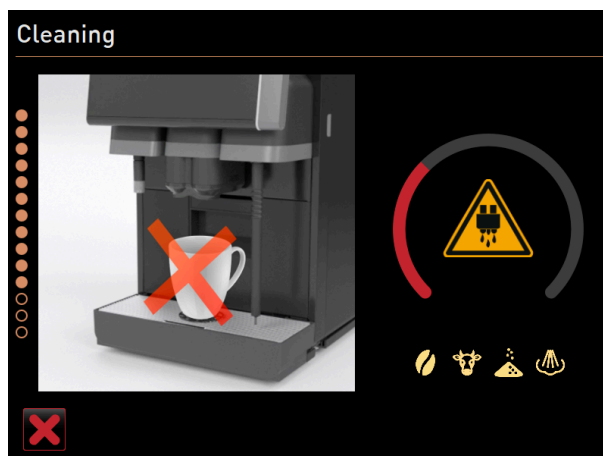

Figure: Progress screen for cleaning

During cleaning, the display shows the following:

- The crossed-out cup indicates that no beverages are available at this time.
- The progress circle indicates the completed and remaining cleaning process.
- A warning of hot liquids escaping is indicated by a warning symbol.
- The systems to be cleaned are highlighted with their icon.

### Removing cleaning container



Figure: Removing cleaning container

1. Pull the adapter(s) of the milk hose out of the cover of the cleaning container and wipe the adapter(s) with a damp cloth.
2. Remove the cleaning container from the cooling unit.
3. Clean and rinse the cleaning container under clean, warm water.
4. Confirm removal of the cleaning container with .

### Milk system activation



Figure: Milk system activation

1. Activate the milk system and confirm with .

### Reinserting milk container



#### WARNING

#### Danger of poisoning!



Cleaning product residues are hazardous to health.

- ▶ After completing cleaning, thoroughly wash your hands with commercial soap.



Figure: Inserting milk container

- ✓ The dialogue with the instruction to insert the milk container(s) appears.
- 1. Reinsert the cleaned milk container(s) into the cooling unit.
- 2. Insert the milk tube adapter back into the cover of the respective milk container.
- 3. When needed, fill with fresh and pre-cooled milk (3 °C – 5 °C or 37.4 °F – 41 °F).  
**ADVICE** Machine equipment options with **Twin Milk** contain 2 milk containers.
- 4. Confirm the connection of the milk container(s) with .

### Completion of planned cleaning

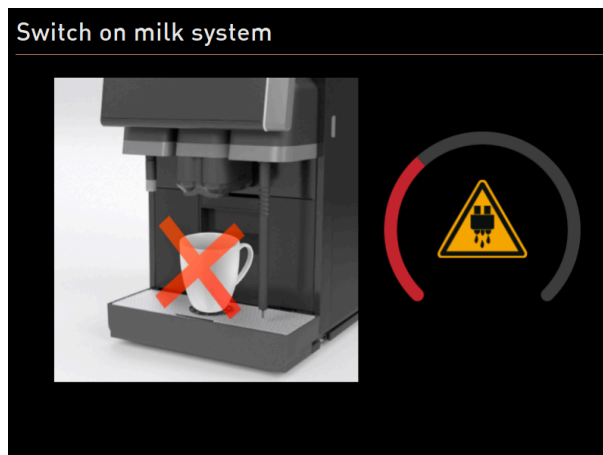

Figure: The milk system switches on.

- ✓ The **Switch on milk system** status screen appears.
- ✓ The system is rinsed.
- ✓ An automatic restart is performed.
- ✓ The next scheduled cleaning in hours [h] appears in the Service menu.
- 1. Clean the drip grid with a brush under running water.
- 2. Reinsert the cleaned drip grid.
  - ✓ The machine is clean and ready for use.

### 9.6.3 Starting scheduled cleaning with ProCare



If the ProCare cleaning process, for whatever reason, was not completely and correctly completed, it must be repeated without fail. The machine can only be ready for use again if the cleaning process has been correctly completed.

The cleaning programme is started in the Service menu. On the touch screen, the user is guided through all required actions.

**Prerequisite:** A pending cleaning is displayed on the **Service menu** button.



Figure: The **Service menu** button with pending cleaning

1. Remove the drip grid for separate cleaning.
2. Tap on the **Service menu**  button.
  - ✓ The Service menu opens.
3. If the cleaning process is PIN-protected, enter the PIN configured for this.
  - ✓ Authorisation is granted.
  - ✓ The **Cleaning** button is active now.



4. Tap on the **Cleaning** button.
  - ✓ The **Cleaning** screen with the menu items for the different cleaning types opens.
5. Tap on the **Scheduled cleaning**  button.

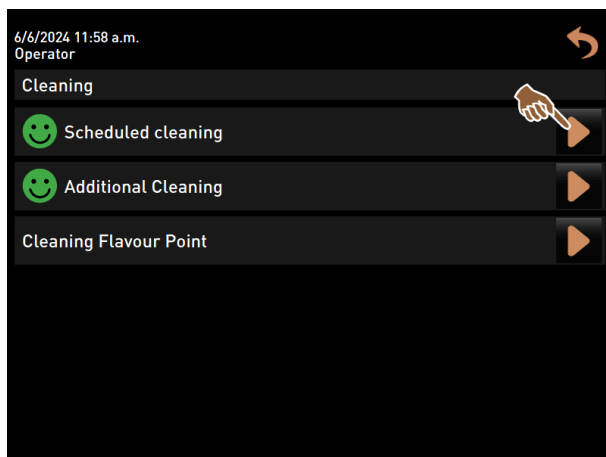

Figure: Opening scheduled cleaning

- ✓ The **Cleaning according to schedule** dialogue opens.

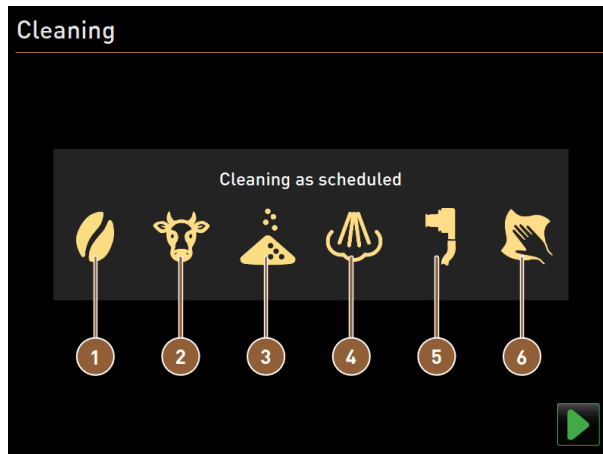



Figure: Dialogue for cleaning according to cleaning schedule

- |   |                               |   |                                      |
|---|-------------------------------|---|--------------------------------------|
| 1 | Cleaning of the coffee system | 4 | Cleaning of the boiler system        |
| 2 | Cleaning of the milk system   | 5 | Plug&Clean cleaning                  |
| 3 | Cleaning of the powder system | 6 | Display-guided manual cleaning steps |
6. Start the scheduled cleaning with .
- ✓ Cleaning is started according to the set cleaning schedule.
  - ✓ The systems to be cleaned are highlighted in the dialogue with their icon.

#### Connecting 1 Plug&Clean connection



Figure: Connecting milk hoses to **Plug&Clean** connections

1. Open the door of the cooling unit.
2. Remove the milk hose(s) from the milk container.
3. Connect the milk hose(s) to the respective **Plug&Clean** connections on the **ProCare** unit.

### Display-guided manual cleaning steps

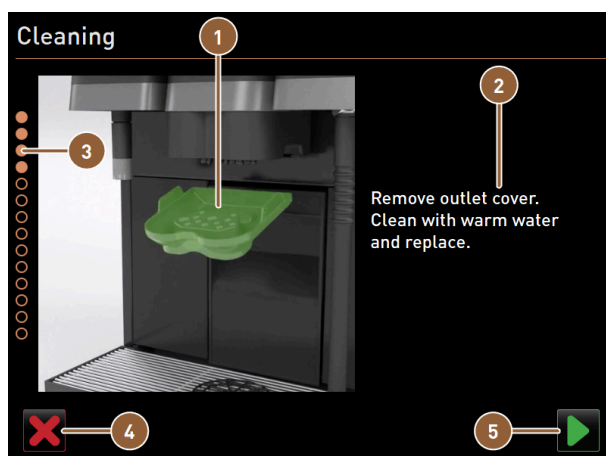



Figure: Start dialogue for cleaning programme

- |   |                                       |   |                                      |
|---|---------------------------------------|---|--------------------------------------|
| 1 | Image or animation for current action | 4 | Button for cancelling cleaning       |
| 2 | Action request or information text    | 5 | <b>Next</b> button for the next step |
| 3 | Progress screen                       |   |                                      |

1. Follow the instructions on the display.
2. After completing the activities shown on the screen, tap on  to go to the next cleaning step.

### Manual cleaning: Grounds container

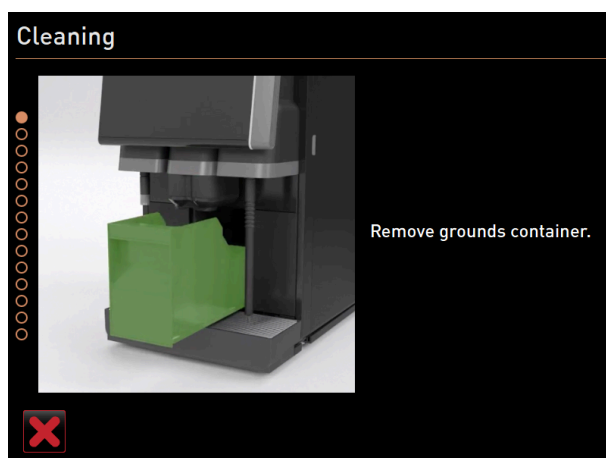

Figure: Removing grounds container

1. Slide the beverage outlet upwards.
2. Pull the grounds container out of the machine.

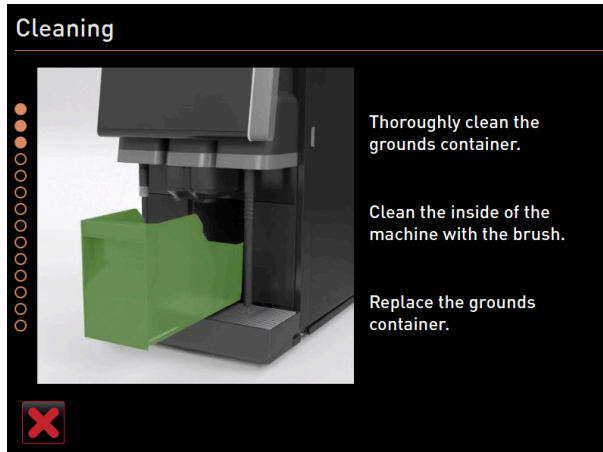

Figure: Replacing the grounds container

- ✓ The instruction to thoroughly clean the grounds container, clean the machine interior with a brush and reinsert the grounds container appears.
3. Wipe any remaining ground coffee out of the brewing chamber with the brush.
  4. Empty the grounds container and clean and rinse it with fresh water and detergent, then dry.
  5. Reinsert the grounds container into the cooling unit up to the stop.
    - ✓ The **Remove beverage outlet cover** instruction appears.

#### Manual cleaning: Beverage outlet cover

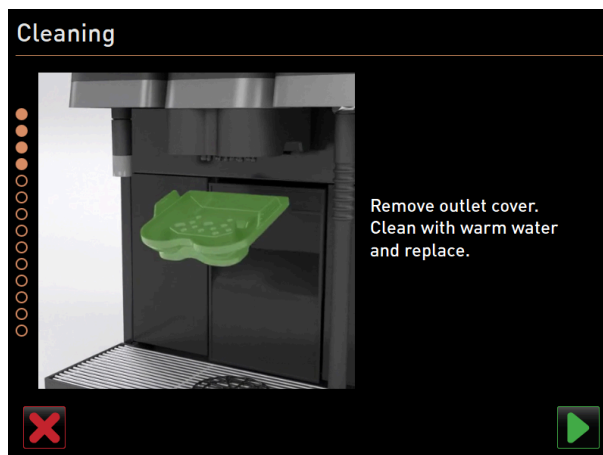



Figure: Removing beverage outlet cover

1. Release the beverage outlet cover by pressing it in the centre and pulling it down at the same time.
2. Clean the beverage outlet cover under warm running water using a brush.
3. Replace the cleaned cover by clipping the cover into place at the back and snapping it into place at the front.
 

**Caution** An incorrectly inserted beverage outlet cover can cause spraying during beverage dispensing.
4. Check that the beverage outlet cover is correctly positioned.
5. Confirm with the  button to get to the next step.

**Manual cleaning: Mixing cup**

Figure: Lifting user panel

1. Unlock the user panel at the top by pulling it firmly towards you.
  - ✓ The user panel is unlocked.
2. Push the user panel from below using both hands until it snaps into place.
  - ✓ The user panel is automatically held in the upper position.
  - ✓ The mixing cup is accessible.

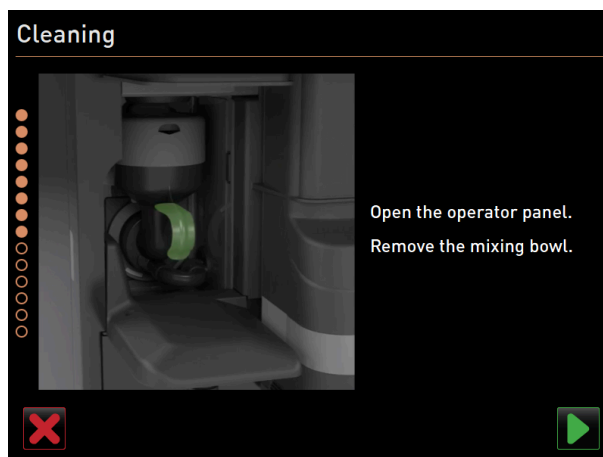



Figure: Pulling out mixing cup

3. Pull the mixing cup out of the machine by the recessed grip.
4. Confirm removal of the mixing cup with .

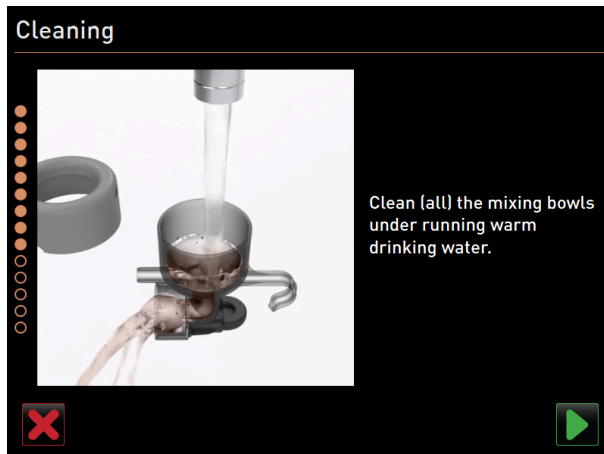



Figure: Cleaning mixing cup

5. Clean and rinse the individual parts of the mixing cup under clean, warm water.
6. Wipe the mixing cup dry with a clean cloth.
7. Confirm cleaning of the mixing cup with .

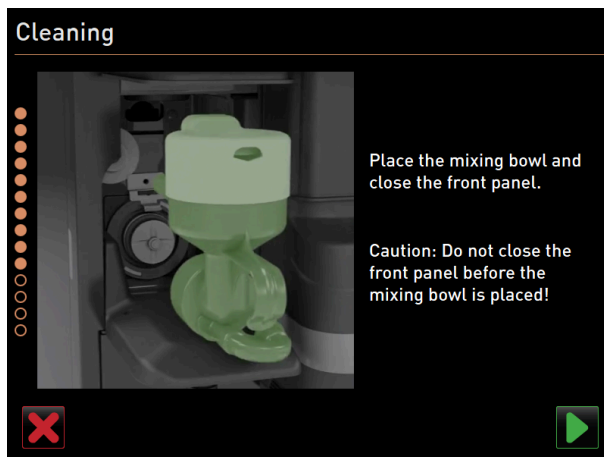



Figure: Inserting mixing cup

8. Reinsert the mixing cup.
9. Check that the mixing cup is correctly positioned.
  - Caution** An incorrectly inserted mixing cup can lead to overflowing.
10. Close the user panel.
11. Confirm cleaning and insertion of the mixing cup with .
  - ✓ The cleaning process starts.

### Progress screen for automatic cleaning

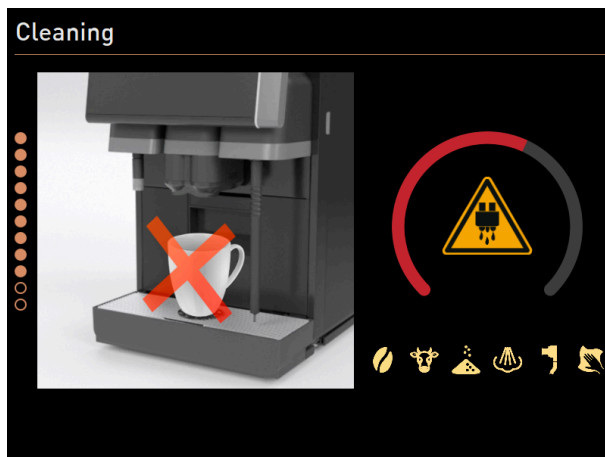

Figure: Progress screen for cleaning

During cleaning, the display shows the following:

- The crossed-out cup indicates that no beverages are available at this time.
- The progress circle indicates the completed and remaining cleaning process.
- A warning of hot liquids escaping is indicated by a warning symbol.
- The systems to be cleaned are highlighted with their icon.

### Removing Plug&Clean connection



Figure: Removing milk hoses from **Plug&Clean** connections

1. Remove the adapter(s) of the milk hose from the respective **Plug&Clean** connection of the **ProCare** unit and wipe the adapter(s) with a damp cloth.

### Reinserting milk container



Figure: Inserting milk container

1. Reinsert the cleaned milk container(s) into the cooling unit.
2. Insert the milk tube adapter back into the cover of the respective milk container.
3. When needed, fill with fresh and pre-cooled milk (3 °C – 5 °C or 37.4 °F – 41 °F).  
**ADVICE** Machine equipment options with **Twin Milk** contain 2 milk containers.
4. Confirm the connection of the milk container(s) with .

### Completion of planned cleaning









Figure: The milk system switches on.

- ✓ The milk system is switched on.
  - ✓ The system is rinsed.
  - ✓ An automatic restart is performed.
  - ✓ The next scheduled cleaning in hours [h] appears in the Service menu.
1. Clean the drip grid with a brush under running water.
  2. Reinsert the cleaned drip grid.
    - ✓ The machine is clean and ready for use.

#### 9.6.4 Additional cleaning

Additional cleaning can be carried out at any time.

-  Coffee system
-  Milk system
-  Powder system
-  Boiler system
-  Milk connection hose piece (Plug&Clean, when cleaning with ProCare)
-  Manual cleaning (when cleaning with ProCare)



### Starting additional cleaning

1. Tap on the **Additional cleaning** button.
  - ✓ The screen with the available systems for cleaning appears.

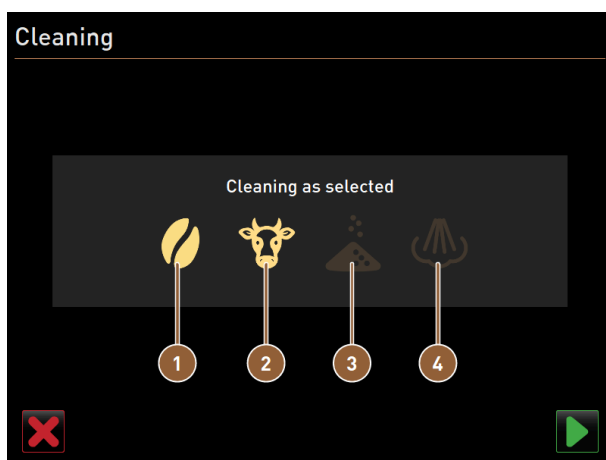

Figure: Dialogue for additional cleaning without ProCare

- |   |                               |   |                               |
|---|-------------------------------|---|-------------------------------|
|  | Cleaning of the coffee system |  | Cleaning of the powder system |
|  | Cleaning of the milk system   |  | Cleaning of the boiler system |

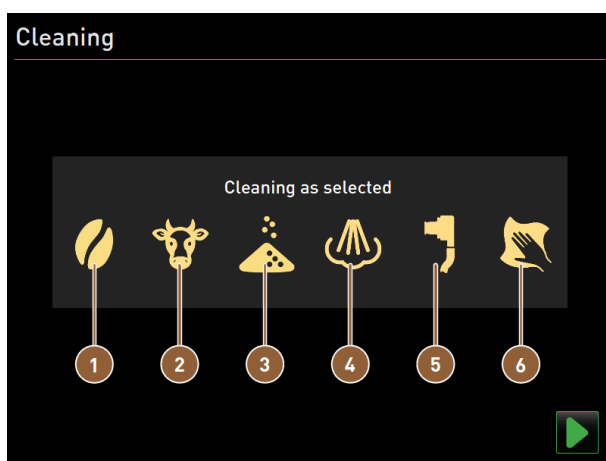



Figure: Dialogue for additional cleaning with ProCare

- |   |                               |   |                                      |
|---|-------------------------------|---|--------------------------------------|
|  | Cleaning of the coffee system |  | Cleaning of the boiler system        |
|  | Cleaning of the milk system   |  | Plug&Clean cleaning                  |
|  | Cleaning of the powder system |  | Display-guided manual cleaning steps |

2. Select the desired systems to be cleaned.
3. Confirm the selection with .

4. Follow the instructions on the machine screen.
  - ✓ The selected systems are cleaned.

### 9.6.5 ProCare: Cleaning (Plug&Clean) milk hose piece

The milk hose (**Plug&Clean**) is cleaned at the end of the cleaning process.

You can trigger the **Plug&Clean** cleaning step manually at any time.

1. To do this, connect the milk hoses to the ProCare milk connection (**Plug&Clean**).
  - ✓ The following dialogue opens:

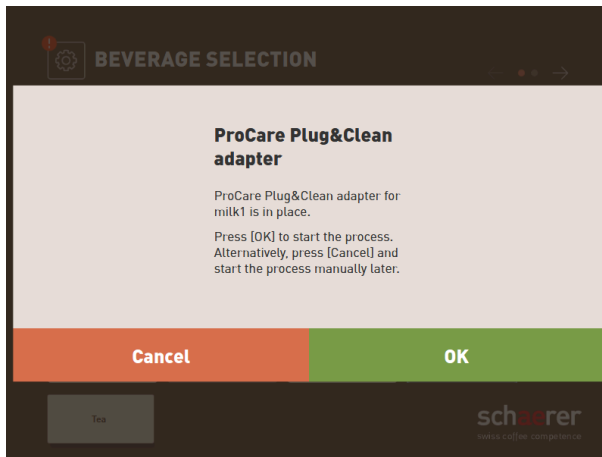

Figure: **Plug&Clean** dialogue

2. Confirm the cleaning on the screen with **OK**.



Figure: Removing milk hoses from **Plug&Clean** connections

3. When cleaning is complete, remove the adapter(s) of the milk hose from the respective **Plug&Clean** connection of the **ProCare** unit and wipe the adapter(s) with a damp cloth.



Figure: Inserting milk container

4. The dialogue with the instruction to insert the milk container(s) appears.
5. Reinsert the cleaned milk container(s) into the cooling unit.
6. Insert the milk tube adapter back into the cover of the respective milk container.
7. When needed, fill with fresh and pre-cooled milk (3 °C – 5 °C or 37.4 °F – 41 °F).
8. Confirm the connection of the milk container(s) with .



Figure: The milk system switches on.

- ✓ The **Switch on milk system** status screen appears.
- ✓ An automatic restart is performed.
- ✓ The machine is clean and ready for use.

### 9.6.6 Display-guided cleaning: Flavour Point (option)



#### CAUTION

##### Danger of scalding!

There is a danger of scalding at the hot water dispensing points. Before cleaning, hot water is dispensed into the cleaning container.

- ▶ Do not reach under the dispensing points during hot water dispensing.
- ▶ Place the cleaning container so that it cannot be overturned.

Have the following utensils ready before the cleaning program:

- Cleaning container with four hose adapters
- Clean and damp cloth



Before cleaning, the cleaning container is filled with hot water via the beverage outlet or optionally via the separate hot water outlet.

### Starting cleaning sequence

Cleaning can be started with the **Caretaker** or **Machine operator** profile or by the service technician.

- ▶ Tap on the **Service menu**  button.
  - ✓ The Service menu opens.

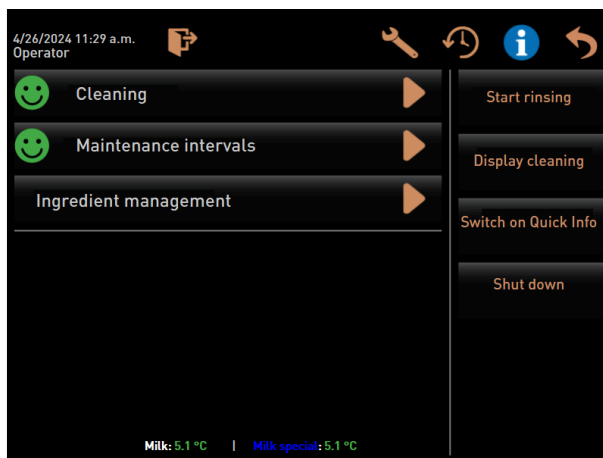



Figure: **Service menu** screen

1. Tap on the  **Cleaning** button.
  - ✓ The screen for selecting a cleaning opens.

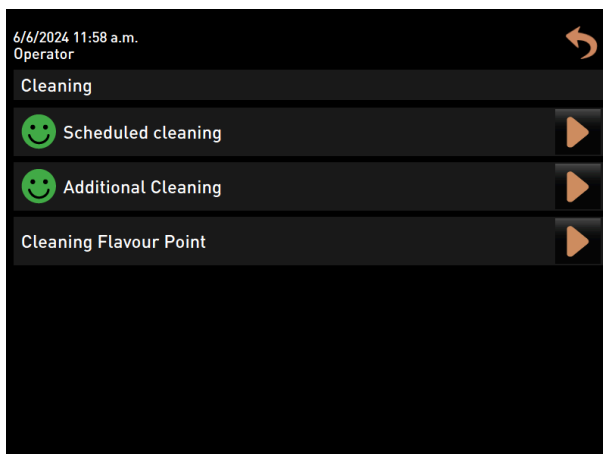



Figure: Screen for selecting the cleaning types

2. Tap on the  **Flavour Point cleaning**.
  - ✓ The **Flavour Point cleaning** dialogue opens.

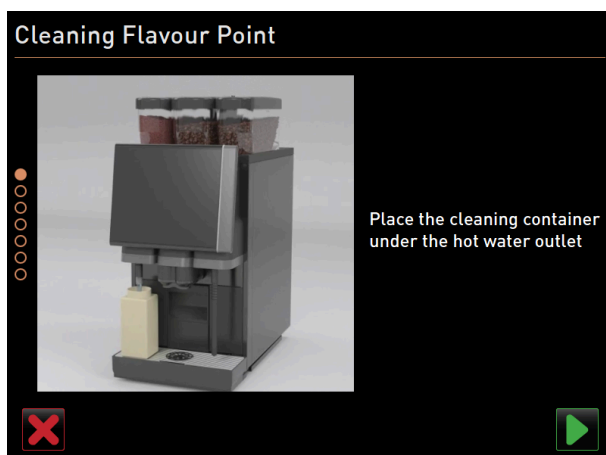



Figure: **Place cleaning container under the hot water outlet** dialogue

- ✓ The **Place cleaning container under the beverage outlet** instruction is displayed.
3. Place the cleaning container under the hot water outlet or beverage outlet (for machines without a separate hot water outlet).
  4. Confirm with the  button to get to the next step.

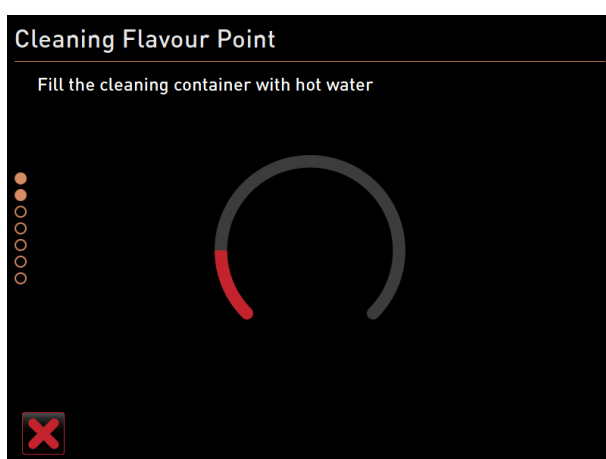

Figure: **Fill cleaning container with hot water** dialogue

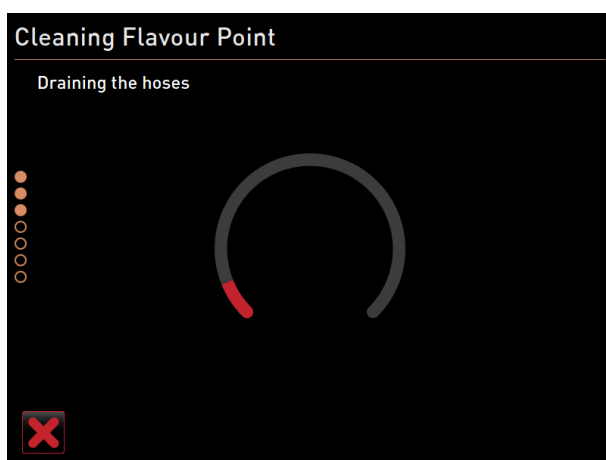

Figure: **Drain hoses** dialogue

- ✓ The cleaning container is filled with hot water.
- ✓ The syrup hoses are then emptied automatically.

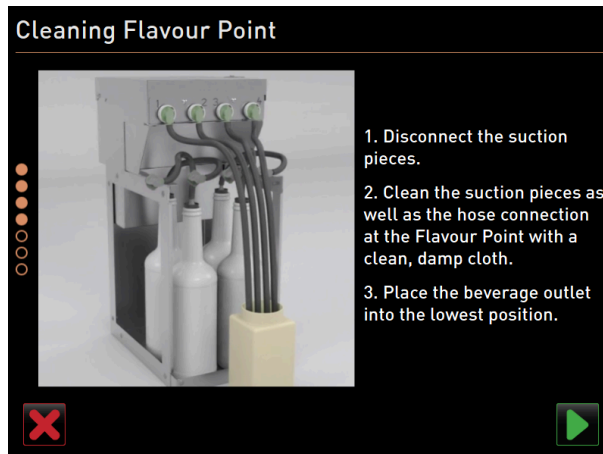

Figure: Connecting cleaning container to Flavour Point

#### Connecting cleaning container to Flavour Point

1. Remove the bayonet locks on the Flavour Point.
2. Clean the bayonet lock and connection to the Flavour Point using a clean, moist cloth.
3. Connect cleaning container hoses to the Flavour Point.
4. Pull the beverage outlet to the lowest position. With machines with automatic beverage outlet, the lowest position is set automatically.
5. Start the cleaning process with the  button.



Figure: Flavour Point cleaning process is running.

#### Cleaning process

- ✓ The cleaning process starts.
- ✓ In this step, the cleaning process lasts 5 to 10 min.

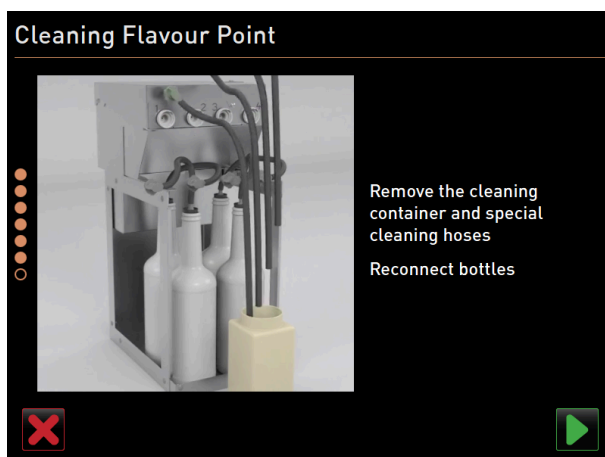



Figure: Removing cleaning container

### Removing cleaning container

1. Remove the cleaning container and cleaning hoses.
2. Connect the syrup bottles back to the Flavour Point.
3. Confirm the connection of the syrup bottles with the  button.
  - ✓ The cleaning process switches to the **Refill flavour** mode.

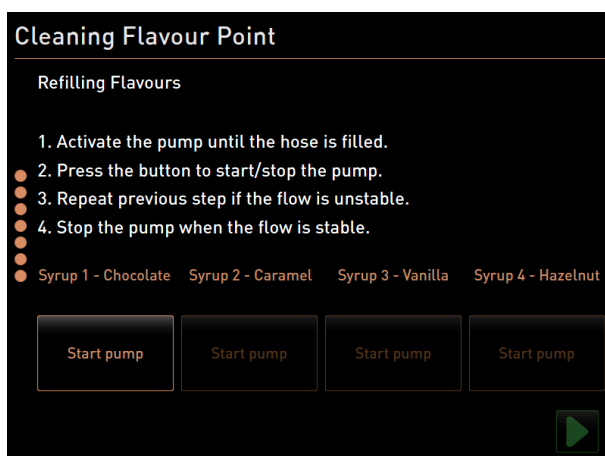



Figure: Filling of syrup hoses





### Filling syrup hoses

1. Tap on the **Start pump** button for syrup 1.
  - ✓ Syrup hose 1 is filled.
  - ✓ The button label changes to **Stop pump**.
  - ✓ After a few seconds, the label changes back to **Start pump** and the button for the next pump is active.
2. Repeat the process with syrup 2 to 4.
  - ✓ All syrup hoses are filled again.
  - ✓ Flavour Point cleaning is now complete.
3. Close the cleaning process with the  button.
  - ✓ The **Flavour Point cleaning** dialogue closes.
  - ✓ The machine is restarted.
  - ✓ After restarting, the machine with the Flavour Point is ready for operation.

## 9.7 Cleaning schedule

### 9.7.1 Calling up cleaning schedule

A standard cleaning schedule is stored in the machine. The cleaning schedule can also be customised by service technicians.

- ▶ Tap on the **Service menu**  button.
  - ✓ The Service menu opens.
- 1. Tap on the **Log out**  button then on **Log in** .
- 2. Log in as a service technician with the corresponding PIN.
- 3. Tap on the **Settings**  button.
  - ✓ The **Settings** opens right away with the system settings.

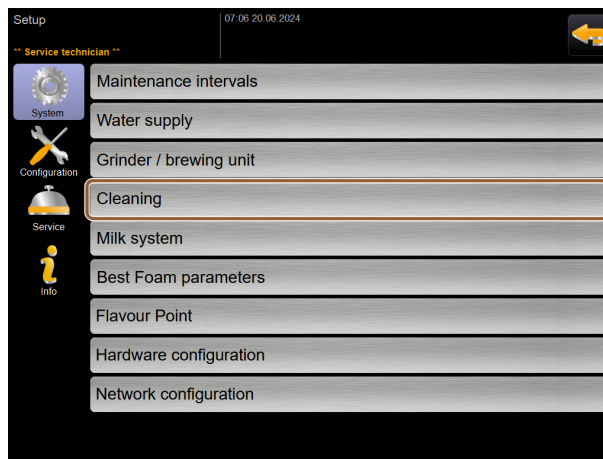

Figure: Calling up cleaning settings

- 4. Click on the **Cleaning** button.
  - ✓ The screen with the cleaning settings appears.

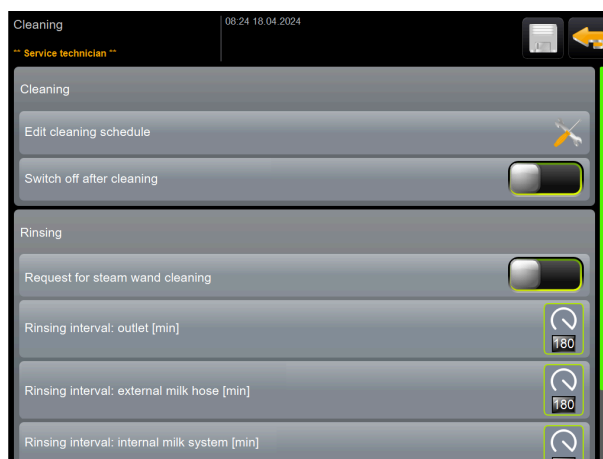

Figure: Screen with the cleaning settings

- 5. Click on the **Cleaning schedule** button.
  - ✓ The schedule for cleaning work appears.

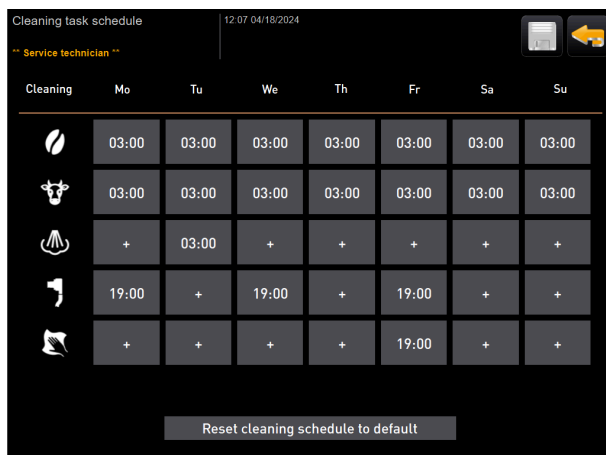

Figure: Schedule for cleaning work

## 9.7.2 Setting cleaning times

Default times are predefined for the cleaning work schedule. If a customised cleaning schedule has been created, it can be reset to default at any time. If a customised cleaning schedule has been reset to *Default*, this cannot be undone.



On the **Cleaning work schedule** screen (global settings), cleaning schedules are set for different systems. Cleaning schedules can be set to daily or on different days of the week at different time intervals.

The following system can be cleaned:

- Coffee system
- Milk system
- Powder system
- Boiler system
- Plug&Clean system (with ProCare)

### To add cleaning work:

1. In the table with the cleaning work, tap on the plus sign in the desired empty field.
  - ✓ The dialogue for adding cleaning work opens.

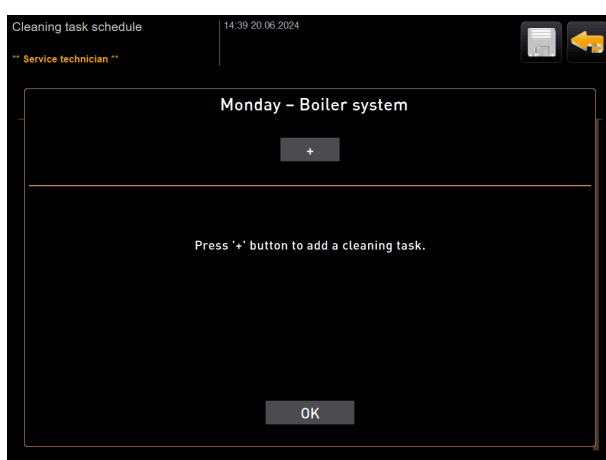

Figure: Dialogue for adding cleaning work

2. Tap on the plus sign and continue as described below.

To edit existing cleaning work:

- ▶ On the **Cleaning work schedule** screen, select a system and the days of the week on which cleaning should be carried out.
  - ✓ The dialogue with the settings appears.

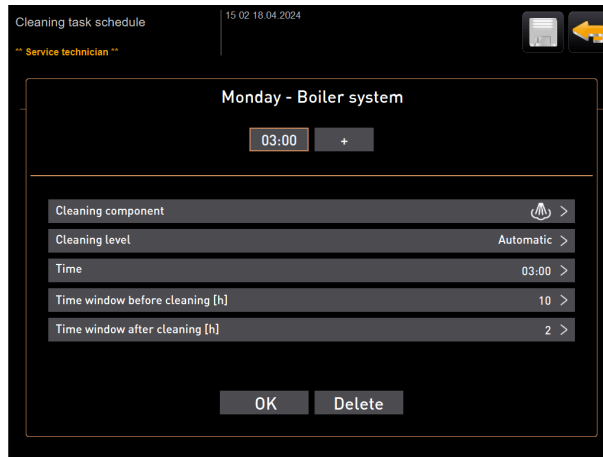

Figure: Schedule for cleaning work of the boiler system

### Defining cleaning step

1. Tap on the **Cleaning step** line.
  - Three cleaning levels are possible:
    - **Instruction** = The coffee machine is still ready for use.
    - **Forced** = The coffee machine is locked.
    - **Automatic** = Cleaning starts automatically. (only with ProCare)
2. Confirm the selection with the **OK** button.
  - ✓ The cleaning stage is saved.

### Defining time

You can define up to four times.

1. To do this, tap on the plus sign next to the time.
2. Tap on the **Time** line.
  - ✓ The dialogue with the time appears.

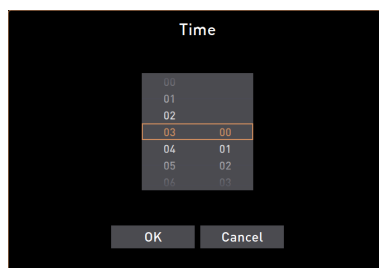

Figure: Selecting time for cleaning

3. Scroll to select the time.
4. Confirm the selection with the **OK** button.
  - ✓ The selected time appears in the dialogue.
5. Confirm the selection with the **OK** button.
  - ✓ The time is saved.
6. Use the **Cancel** button to cancel the respective entry.

### Defining time window before and after cleaning

The **Time window before cleaning [h]** defines the time before scheduled cleaning in which you can move forward this scheduled cleaning.

The **Time window after cleaning [h]** defines the time after scheduled cleaning in which you can make up cleaning before the machine is locked (grace period).

1. Tap on the **Time window before cleaning [h]** or **Time window after cleaning [h]** line.
  - ✓ The dialogue with selection of the hours, similar to that for the time, appears.
2. Scroll to set the time window.
3. Proceed as when setting the time.
  - ✓ The hours for the respective time window are displayed in the dialogue.



The **Time window before cleaning (h)** and **Time window after cleaning (h)** time settings can be used to postpone a scheduled cleaning cycle.

**Example:** A large number of customers are expected at the time of the scheduled cleaning. This can be avoided with the time window before and after cleaning.

## 9.8 Manual cleaning

Various components have to be cleaned manually.

### 9.8.1 Cleaning grounds container



#### CAUTION

#### Health hazard due to mould growth in the grounds container!

Coffee grounds in the grounds container can quickly lead to mould formation. The spread of mould spores in the machine results in danger to health and to contamination of the coffee.

- ▶ Clean the grounds container daily.



#### ADVICE

#### Property damage due to high temperatures!

High temperatures may lead to damage.

- ▶ Never clean the grounds container in the dishwasher.

**Cleaning interval: Daily**

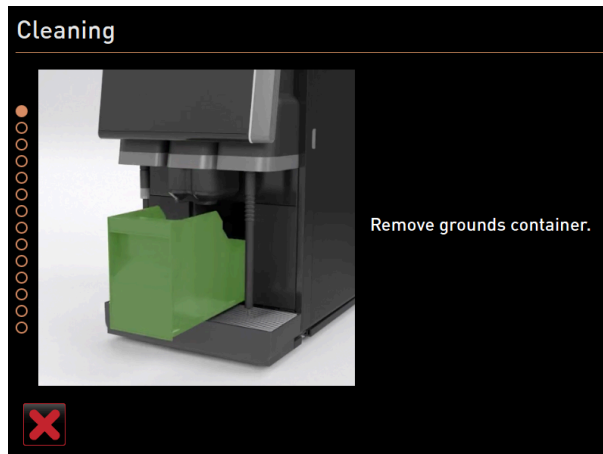

Figure: Removing grounds container

1. Slide the beverage outlet upwards (manual beverage outlet).
2. Pull the grounds container out of the machine.
3. Empty the grounds container.
4. Clean the grounds container thoroughly with water and detergent.
5. Rinse out the grounds container with clean water.
6. Dry the grounds container with a clean cloth.
7. Reinsert the grounds container into the cooling unit.
  - ✓ The grounds container is empty and clean.

## 9.8.2 Cleaning brewing chamber

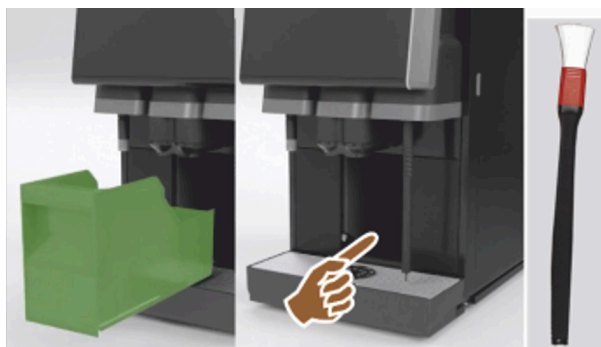

Figure: Cleaning brewing chamber

### Cleaning interval: Daily

1. Slide the beverage outlet upwards (with manual beverage outlet).
2. Pull the grounds container out of the machine.
3. Remove ground coffee from the machine brewing chamber using the supplied cleaning brush.
4. Wipe the brewing chamber dry with a clean, damp cloth.
5. Reinsert the grounds container.
  - ✓ The brewing chamber is cleaned.

### 9.8.3 Cleaning drip tray and drip grid



#### CAUTION

##### Danger of scalding!

Automatic rinsing flushes hot water out of the beverage outlet.

- ▶ When cleaning is done outside of the display-guided cleaning programme: Shut down the machine before the drip grid is removed for cleaning.
- ▶ When cleaning is done outside of the display-guided cleaning programme: Shut down the machine before cleaning the drip tray.



#### ADVICE

##### Risk of flooding!

A plugged waste water outlet causes the drip tray to overflow.

- ▶ Before the descaling process is done, check whether fluid is flowing freely through the waste water outlet.

#### Cleaning interval: Daily

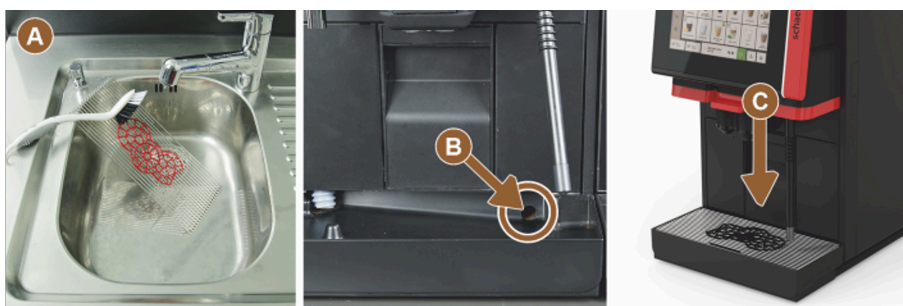

Figure: Cleaning drip tray and drip grid

1. Remove the drip grid with positioning grid **(A)** from the machine.
2. Thoroughly clean the drip grid with positioning grid with a brush under running water and with detergent.
3. Rinse out the machine drip tray with clean water.
4. Check if waste water outlet **(B)** is plugged.
5. Place the drip grid back into the drip tray and check that the drip tray is correctly positioned.
6. Check that the positioning grid **(C)** is positioned correctly in regard to the beverage outlet.
  - ✓ Drip tray and drip grid are cleaned.

### 9.8.4 Cleaning milk container



#### WARNING

##### Risk of infection!



There is a risk of infection due to contamination, milk deposits and bacteria.

- ▶ Clean the milk container and cover before each filling.
- ▶ Wear protective gloves when cleaning.

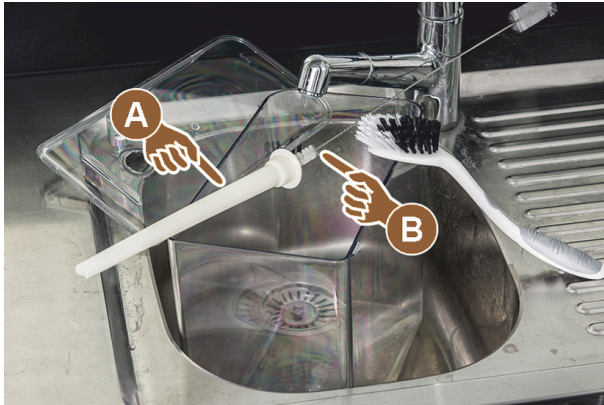

Figure: Cleaning milk container

**Cleaning interval: Daily**

1. Remove the milk container from the cooling unit.
2. Dispose of the remaining milk from the milk container.  
Observe the detailed cleaning instructions in the separate operating instructions for the **optional accessories**.
3. Clean the milk container with fresh water, detergent and a clean, unused cloth.
4. Clean the riser pipe **(A)** with the supplied brush **(B)**.
5. Reinsert the milk container into the cooling unit.  
✓ The milk container is cleaned.

### 9.8.5 Cleaning cooling unit (optional)



Figure: Cleaning cooling unit

**Cleaning interval: Daily**

1. Take the milk container out of the cooling unit.
2. Wipe out the inside of the cooling unit with fresh water and a fresh, unused cloth.
3. Reinsert the milk container into the cooling unit.  
✓ The cooling unit is cleaned.

## 9.8.6 Defrosting cooling unit (optional)



### ADVICE

#### Property damage due to sharp-edged objects

The surface of the cooling unit interior can be damaged.

- ▶ Do not remove the ice layer using sharp or pointed objects.
- ▶ Always allow layers of ice to defrost.



Figure: Defrosting of cooling unit

1. Switch off the side cooling unit or pull out the mains plug.
2. Open the front door and leave it open.
3. Wipe up the condensation water with an absorbent cloth.
4. Wait until the ice layer has melted completely.
5. Close the front door and switch the device back on or reconnect the mains plug.



See 8.2 "Switching on"

## 9.8.7 Cleaning touch screen



### CAUTION

#### Danger of scalding!

Unsupervised beverage dispensing can cause scalding during cleaning.

- ▶ Deactivate the touch screen in the Service menu before cleaning or switch off the machine.



## ADVICE

**Damage to the touch screen during cleaning process**

Improper cleaning can scratch or otherwise damage the surface of the touch screen.

- ▶ Do not use scouring agents.
- ▶ Never use force, strong pressure or sharp objects when pressing on the display.

**Cleaning interval: Daily**

- ▶ Tap on the **Service menu**  button.
  - ✓ The Service menu opens.

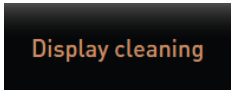

Figure: **Touch screen cleaning** button

1. Tap on the **Touch screen cleaning** button.
  - ✓ The touch screen is deactivated for 30 s and no longer reacts to touch.
  - ✓ A countdown is displayed.
2. During the available 30 s, clean the touch screen with a paper towel and a commercial glass cleaner.
  - ✓ After the countdown ends, the touch screen is reactivated.
  - ✓ The touch screen is cleaned.

## 9.8.8 Cleaning steam wand (optional)



## WARNING

**Risk of infection!**

There is a risk of infection due to contamination, deposits and bacteria on the steam wand.

- ▶ Wipe the steam wand with a clean, damp cloth after each use.
- ▶ Wear protective gloves when cleaning.



Figure: Clean steam wand

1. Press the steam dispensing button **(A)** several times to remove milk remains from the steam wand.
2. Wipe the milk remains off the steam wand using a clean, damp cloth.

The position of the optional button **(A)** for steam dispensing depends on the selected user interface.

### 9.8.9 Cleaning external drinking water tank



#### DANGER

##### **Danger of poisoning from cleaning products!**

Cleaning product residues in the drinking water tank can lead to poisoning.

- ▶ Never pour cleaning products into the drinking water tank.



#### WARNING

##### **Risk of infection from bacteria!**

There is a risk of infection due to contamination, deposits and bacteria. Contamination can lead to health problems.

- ▶ Wear protective gloves when cleaning.



Figure: External drinking water tank

#### **Cleaning interval: Daily**

1. Unscrew the cover of the external drinking water tank.
2. Pull the drinking water hose of the machine out of the external drinking water tank and the cover.
3. Lay the end of the drinking water hose on a clean cloth.
4. Rinse the external drinking water tank thoroughly with fresh water multiple times. Do not use cleaning products.
5. Clean the cover of the external drinking water tank with fresh water and dry it with a clean cloth.
6. Fill the external drinking water tank with fresh water.
7. Check if the floater can move freely (fill level monitoring).
8. Lead the water hose back through the cover and into the external drinking water tank.
9. Close the external drinking water tank with the cover.
  - ✓ The external drinking water tank is cleaned.

### 9.8.10 Cleaning external waste water tank



#### WARNING

##### **Risk of infection from bacteria!**

There is a risk of infection due to contamination, deposits and bacteria. Contamination can lead to health problems.

- ▶ Wear protective gloves when cleaning.





Figure: External waste water tank

**Cleaning interval: Daily**

1. Unscrew the cover of the waste water tank.
2. Pull the waste water hose of the machine out of the waste water tank and the cover.
3. Lay the end of the waste water hose on a clean cloth.
4. Rinse the external waste water tank thoroughly multiple times with fresh water. Do not use cleaning products.
5. Clean the cover of the waste water tank thoroughly with fresh water.
6. Dry the cover of the waste water tank with a clean cloth.
7. Check if the floater can move freely (fill level monitoring).
8. Guide the waste water hose back into the waste water tank through the cover.
9. Close the waste water tank with the cover.
  - ✓ The external waste water tank is cleaned.

**9.8.11 Cleaning optional accessories**

Care and cleaning of the optional accessories are described in the separate operating instructions 020888.

**9.8.12 Cleaning bean hoppers****CAUTION****Danger of injury due to rotating grinding discs!**

There is a risk of cuts due to rotating grinding discs in the grinder.

- ▶ Never reach into the bean hopper when the machine is switched on.
- ▶ Wear gloves when cleaning.

**ADVICE****Damage to the machine surface!**

The machine surface can be scratched by abrasive cleaners.

- ▶ Do not use scouring agents for cleaning.

**Cleaning interval: Weekly**

- ▶ Tap on the **Service menu**  button.
  - ✓ The Service menu opens.

Shut down

Figure: **Switch-off** button

1. Tap on the **Switch-off** button.
  - ✓ The machine is in Standby mode.

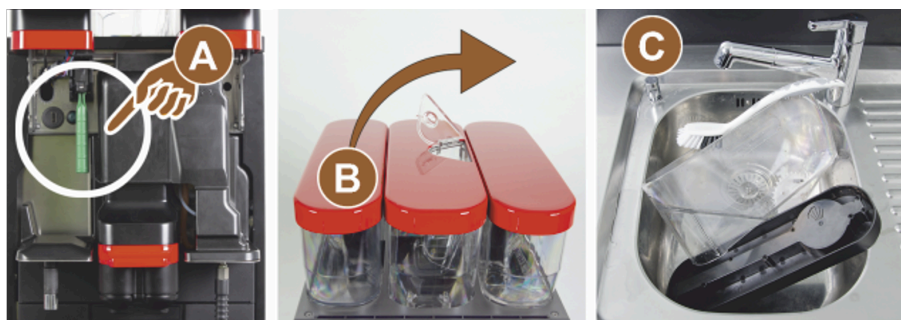

Figure: Cleaning bean hoppers

2. Unlock the bean hoppers with the central locking mechanism behind the user panel **(A)**.



See 4.3.2 "Machine operating elements"

3. Lift the bean hoppers out of the machine **(B)**.
4. Remove the remaining coffee beans from the machine and the bean hoppers.
5. Rinse the bean hoppers thoroughly under running water **(C)**.
6. Wipe the bean hoppers and cover dry with a clean cloth.
7. Put the bean hoppers back into the machine.
8. Lock the bean hoppers with the central locking mechanism.
9. Fill the bean hoppers and put on the covers, close the closing device for the cover if present.
  - ✓ The bean hoppers are clean.

### 9.8.13 Cleaning lower beverage outlet



CAUTION

#### Danger of scalding!

Automatic rinsing flushes hot water out of the beverage outlet.

- ▶ When cleaning is done outside of the display-guided cleaning programme: Shut down the machine before the drip grid is removed for cleaning.
- ▶ When cleaning is done outside of the display-guided cleaning programme: Shut down the machine before cleaning the drip tray.

If you carry out this cleaning step outside of the display-guided cleaning program:

- ▶ Tap on the **Service menu**  button.
  - ✓ The Service menu opens.

Shut down

Figure: **Switch-off** button

1. Tap on the **Switch-off** button.
  - ✓ The machine is in Standby mode.

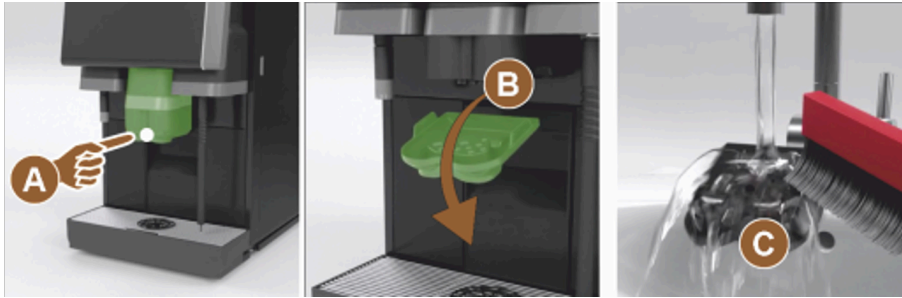

Figure: Beverage outlet bottom cover removal

1. Remove the cover of the beverage outlet at the front **(A)** by releasing it (push and pull downwards).
2. Clean the beverage outlet **(B)** with a brush and water.
3. Clean the lower beverage outlet **(C)** under running water and a brush.
4. Mount the cover to the beverage outlet by inserting it into the rear and clipping it into place at the front.
  - ✓ The lower part of the beverage outlet is cleaned.

**These steps only apply to cleaning outside of the display-guided cleaning programme:**

1. Unlock the user panel and slide it upwards.
2. Switch on the machine.
3. Close the user panel by slightly lifting it until it disengages and then press it down until it engages.

### 9.8.14 Cleaning powder container (option)

The powder system can be equipped with a standard powder container for one powder or with a Twin powder container for two powders.

The design of the powder containers differs. The assembly and disassembly steps differ slightly.

**Cleaning interval: As needed**

Preparation

1. Switch off the machine.
  - See 8.10 "Switch-off"
2. Unlock the powder container using the central locking mechanism behind the user panel.
3. Lift the powder container out of the machine.
4. Remove the cover by opening the closing device, if present.
5. Remove any remaining powder.
6. Dismantle the powder container according to the following instructions.



**ADVICE**

**Damage to the powder container**

The powder containers could get scratched by scouring agents.

- ▶ Do not use scouring agents for cleaning.

**Cleaning powder container**

1. Rinse the powder container and individual parts of the dosing mechanism thoroughly under running water.
2. Allow all parts to dry thoroughly before reassembling.

## 9.8.14.1 Dismantling standard powder container

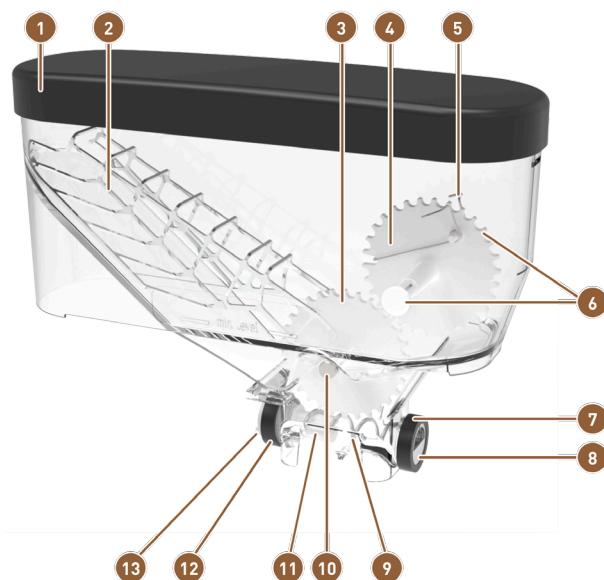

Figure: Parts of the standard powder container (2 kg)

- |   |   |    |                              |
|---|---|----|------------------------------|
| 1 | Cover   | 8  | Outlet restrictor            |
| 2 | Powder scoop  | 9  | Dosing screw                 |
| 3 | Lower toothed wheel                                     | 10 | Axis for lower toothed wheel |
| 4 | Upper toothed wheel                                     | 11 | Dosing screw holder          |
| 5 | Powder loosening unit                                   | 12 | Cap nut for drive            |
| 6 | Locking for upper toothed wheel (rear axis not visible) | 13 | Driver for drive             |
| 7 | Cap nut for outlet restrictor                           |    |                              |

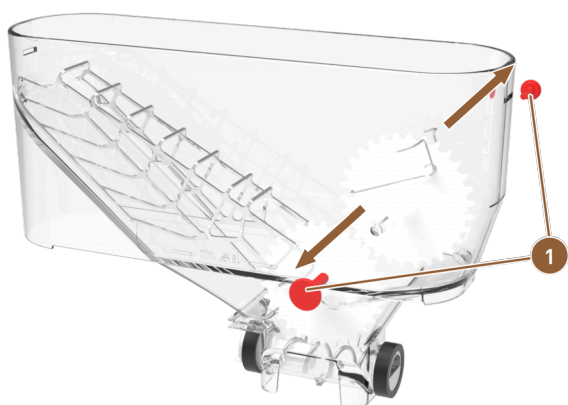

Figure: Standard powder container: Removing locking pin

- 1 Locking pin for upper toothed wheel

1. Pull out the two locking pins **(1)** on the right and left for the upper toothed wheel.
  - ✓ The toothed wheel with the powder loosening spring is free.



Figure: Standard powder container: Removing powder loosening unit

- 1 Top toothed wheel for loosening powder      2 Powder loosening spring

2. Lift the toothed wheel **(1)** with the powder loosening spring **(2)** out of the powder container.
3. Pull the eyelets of the spring apart slightly and remove the spring from the bracket on the toothed wheel.
  - ✓ Toothed wheel and spring are separated.



Figure: Standard powder container: Removing lower axis

- 1 Axle for lower toothed wheel

4. Press the axle **(1)** for the lower toothed wheel out of the powder container.
  - ✓ The lower toothed wheel with the powder scoop is free.



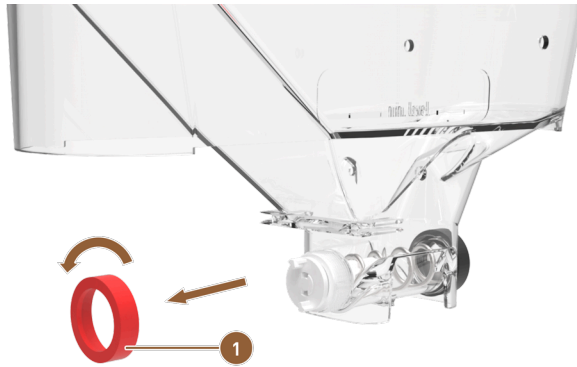

Figure: Standard powder container: Removing cap nut on feed side

- ① Cap nut on feed side

9. Loosen the cap nut **(1)** by turning it to the left and remove it.  
 ✓ The supply unit can be removed.

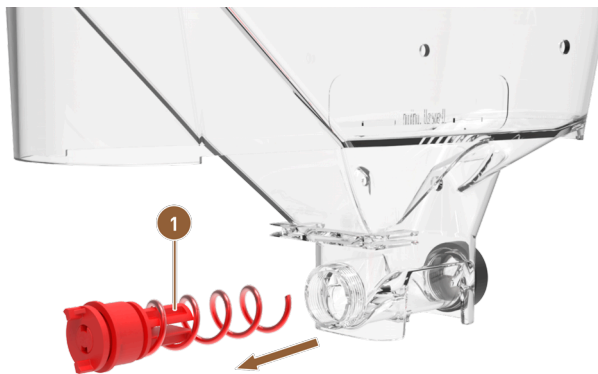

Figure: Standard powder container: Removing supply unit

- ① Feed unit with dosing screw and drive

10. Pull the supply unit **(1)** out of the powder container.  
 ✓ The powder container housing is empty.



Figure: Standard powder container: Disassembling supply unit

- |                |                |
|----------------|----------------|
| ① Driver       | ③ Screw holder |
| ② Drive flange | ④ Dosing screw |

11. Turn the driver **(1)** 90° to the left and pull it off the drive flange **(2)**.
12. Pull the drive flange **(2)** off the screw holder **(3)**.
13. Pull the dosing screw **(4)** off the screw holder **(3)**.
  - ✓ The entire powder container is disassembled and can be cleaned.

#### 9.8.14.2 Dismantling Twin powder container

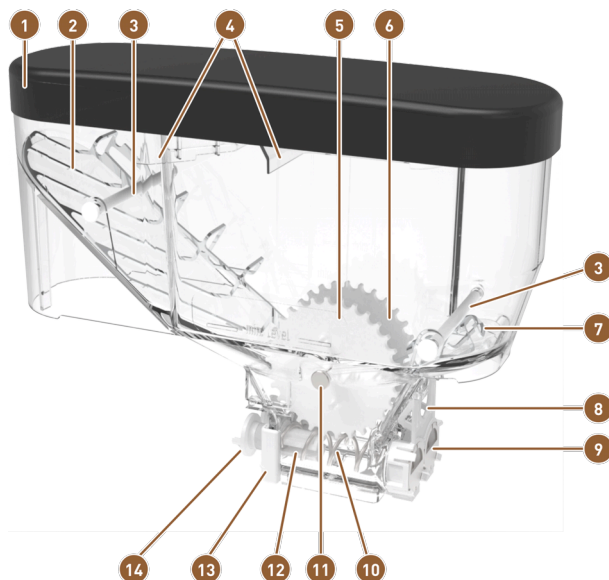

Figure: Parts of the Twin powder container (2x 1 kg)

- |          |                            |           |                                      |
|----------|----------------------------|-----------|--------------------------------------|
| <b>1</b> | Cover                      | <b>8</b>  | Restrictor for Twin powder container |
| <b>2</b> | Powder scoop               | <b>9</b>  | Powder container outlet restrictor   |
| <b>3</b> | Crossbar or bolt           | <b>10</b> | Twin dosing screw                    |
| <b>4</b> | Power filling aid          | <b>11</b> | Toothed wheel axis                   |
| <b>5</b> | Toothed wheel for powder 1 | <b>12</b> | Dosing screw holder                  |
| <b>6</b> | Toothed wheel for powder 2 | <b>13</b> | Drive holder for dosing screws       |
| <b>7</b> | Powder loosening unit      | <b>14</b> | Driver for drive                     |

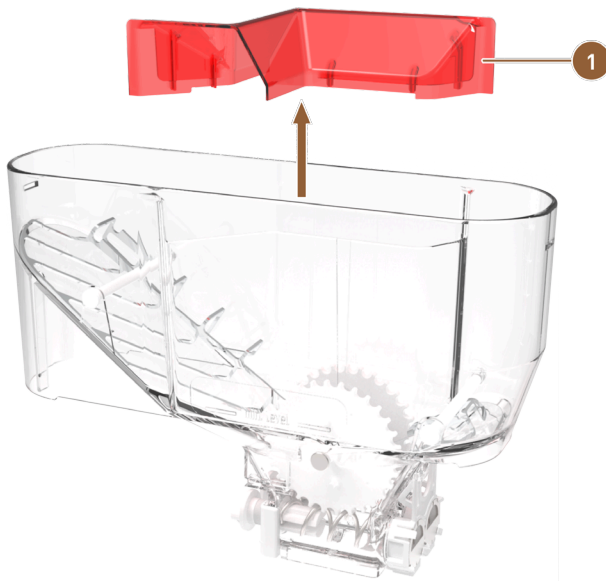

Figure: Twin powder container

① Filling aid for separating powder

1. Remove the filling aid **(1)** upwards from the powder container.

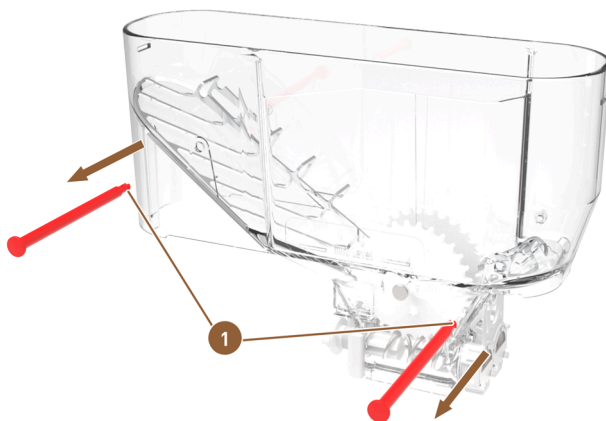

Figure: Twin powder container: Removing crossbars

① Crossbars with locking lugs

2. Press the locking lugs of the crossbars **(1)** together and push both crossbars out of the powder container.
  - ✓ The powder scoops are accessible.

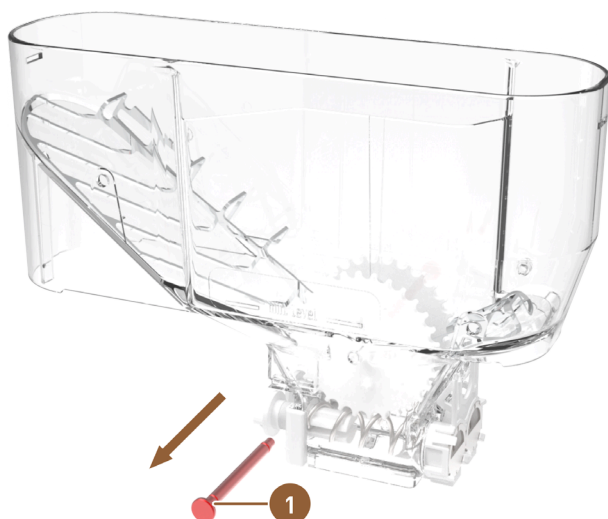

Figure: Twin powder container: Removing toothed wheel axis

**1** Axis for both toothed wheels

3. Press the common axle **(1)** for both toothed wheels out of the powder container.
  - ✓ The lower toothed wheels with the powder scoops are free.

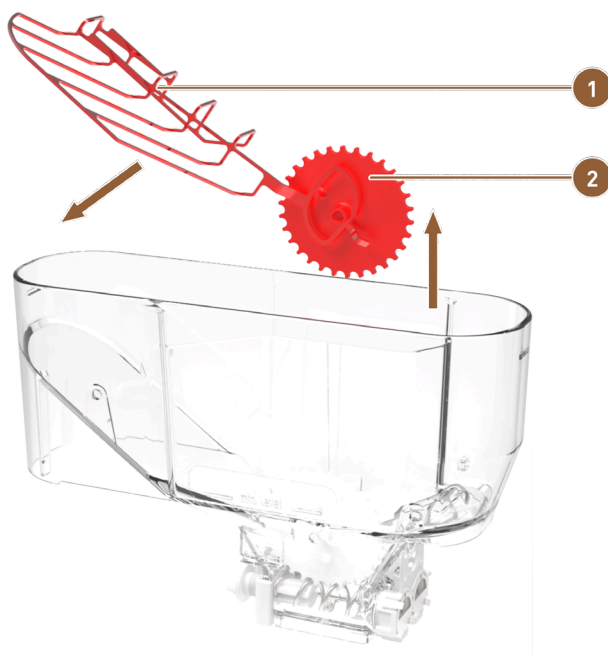

Figure: Twin powder container: Removing powder scoop

**1** Powder scoop

**2** Right toothed wheel for powder scoop

4. Lift the right toothed wheel **(2)** out of the powder container with the powder scoop **(1)**.
5. Remove the powder scoop from the axle of the toothed wheel.
  - ✓ Toothed wheel and powder scoop are separated.



Figure: Twin powder container: Removing powder loosening unit

- 1 Left toothed wheel for loosening powder
 2 Metal grid for loosening powder

6. Lift the left toothed wheel **(1)** with the short metal grid for loosening powder **(2)** out of the powder container.
7. Take the metal grid for loosening powder off the toothed wheel axis.
  - ✓ Toothed wheel and metal grid are separated.



Figure: Twin powder container: Removing dosing element

- 1 Restrictor with eyelets
 4 Lower locking lugs for outlet restrictor  
2 Guide groove on powder container
 5 Outlet restrictor  
3 Upper locking lugs for outlet restrictor

8. Press the eyelets of the dosing unit **(1)** apart and pull them off the powder container.
9. Pull the dosing unit horizontally out of the guide groove **(2)** on the powder container.
  - ✓ The entire dosing unit is detached from the powder container.
10. Press the upper locking lugs **(3)** away from the outlet restrictor **(5)**.
11. Press the lower locking lugs **(4)** away from the outlet restrictor and remove the outlet restrictor.
  - ✓ The dosing unit is separated from the powder container and disassembled.

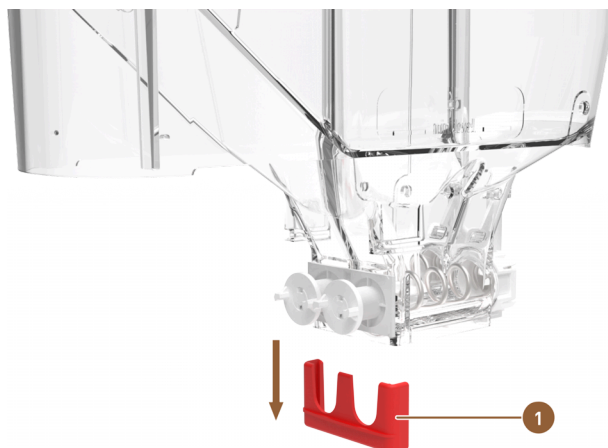

Figure: Twin powder container: Removing drive holder

- ① Bracket for the feed unit

12. Press the bracket for the feed unit **(1)** downwards from the powder container.

13. The supply unit can be removed.



Figure: Twin powder container: Removing supply unit

- ① Feed unit with dosing screws and drives

14. Pull the supply unit **(1)** out of the powder container.

✓ The powder container housing is empty.

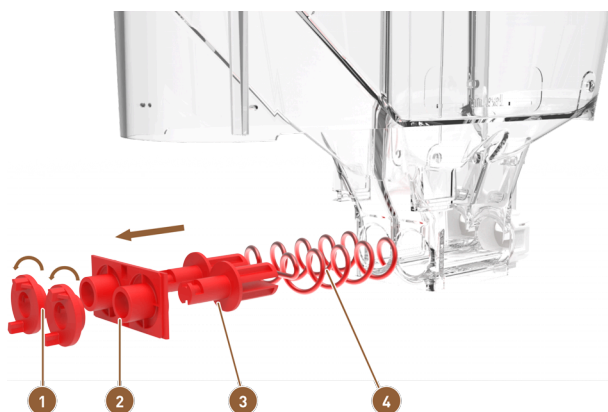

Figure: Twin powder container: Disassembling supply unit

- |                       |                              |
|-----------------------|------------------------------|
| <b>1</b> Driver       | <b>3</b> Dosing screw holder |
| <b>2</b> Drive flange | <b>4</b> Dosing screw        |

15. Turn both drivers **(1)** 90° to the left and pull them off the drive flange **(2)**.

16. Pull the drive flange **(2)** off the dosing screw holders **(3)**.

17. Pull the dosing screws **(4)** off the dosing screw holders **(3)**.

- ✓ The entire powder container is disassembled and can be cleaned.

#### 9.8.14.3 Assembling powder container

1. Reassemble the powder container in reverse order.

2. Put the powder container in the machine.

3. Replace the cover and close the closing device, if present.

4. Lock the powder container using the central locking mechanism behind the user panel.

- ✓ The powder container is cleaned and reinserted into the machine.

### 9.8.15 Cleaning outer surfaces



#### ADVICE

#### Damage to the machine surface!

The machine surface can be scratched by abrasive cleaners.

- ▶ Do not use scouring agents for cleaning.

▶ Tap on the **Service menu**  button.

- ✓ The Service menu opens.

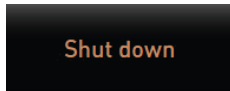

Figure: **Switch-off** button

1. Tap on the **Switch-off** button.

- ✓ The machine is in Standby mode.

2. Wipe the outer surfaces of the machine and the optional accessories with a clean, damp cloth.

3. Unlock the user panel and slide it upwards until it engages.

4. Switch the machine back on using the switch-on button.

5. Slightly lift the user panel and slide it back downwards until it engages.

- ✓ The machine is switched on and ready for use.



See 9.8.7 "Cleaning touch screen"

## 10 Maintenance

Maintenance is divided into the following categories:

- **Maintenance work:** Maintenance work must not be carried out by the operator. If maintenance work is due, the service partner must be informed, who will then carry out the maintenance work.
- **Descaling with mains water supply:** Descaling can be carried out by the operator. A decalcification cartridge **079293** is required for descaling.

### 10.1 Maintenance work

The machine requires regular maintenance. The maintenance schedule depends on multiple factors, especially the degree to which the machine is used and the service life of the safety valves.

When maintenance is due, the machine indicates this on the display. The machine can continue to be operated normally.

#### 10.1.1 Maintenance intervals

##### ADVICE

##### Property damage due non-observance of maintenance intervals!

Putting off maintenance can lead to premature wear.

- ▶ Have pending maintenance work done by your service partner as quickly as possible.

Maintenance intervals are defined in the separate maintenance regulations.

Safety-relevant components	24 months	48 months	72 months
Hot water boiler	Check (only replace if necessary)	(Replace)	Check (only replace if necessary)
Steam boiler	Check (only replace if necessary)	(Replace)	Check (only replace if necessary)
Safety valve 12 bar	(Replace)	(Replace)	(Replace)
Safety valve 5 bar	(Replace)	(Replace)	(Replace)

##### Requirements for maintenance:

1. If maintenance is due, contact the service partner.
2. Perform all descaling intervals in line with the instructions displayed by the machine.
3. Perform a descaling procedure a day before maintenance work.



See 10.2 "Descaling"

#### 10.1.2 Having maintenance work done and resetting counter

The **Maintenance interval** function is PIN protected (caretaker, machine operator, service technician).

- ▶ Tap on the **Service menu**  button.
  - ✓ The Service menu opens.

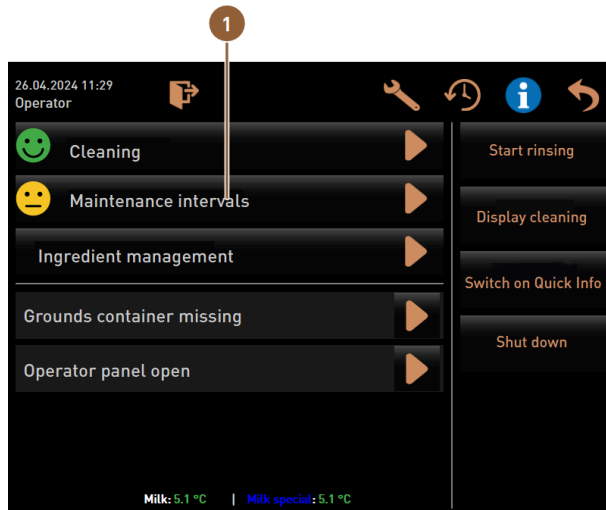
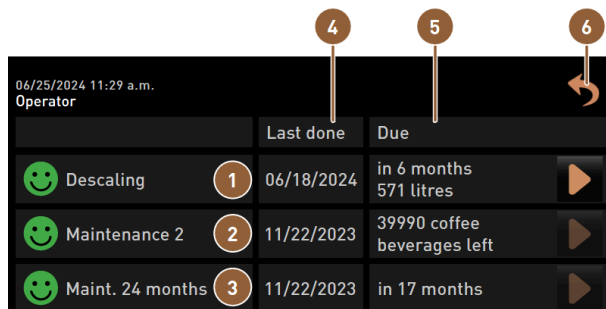

Figure: Calling up maintenance intervals

The **Maintenance intervals (1)** button shows the maintenance status of the machine with a smiley.

- Green smiley: The machine does not have to undergo maintenance.
- Yellow smiley: The machine has to undergo maintenance soon.
- Red smiley: The machine has to undergo maintenance.

1. Tap on the **Maintenance intervals** button in the Service menu.
  - ✓ The **Maintenance intervals** screen opens.

Figure: **Maintenance intervals** screen

- |  |                              |
|--|------------------------------|
| 1 Descaling                                  | 4 Last maintenance performed |
| 2 Maintenance 2 by service technician        | 5 Maintenance due            |
| 3 24-month maintenance by service technician | 6 <b>Back</b> button         |

The ▶ button is used to start the pending **descaling (1)** process.

The ▶ button displays a query for **maintenance 2 (2)** and **24-month maintenance (3)**. The machine must undergo maintenance by a service partner in accordance with the separate maintenance regulations. Once maintenance has been completed, the query can be confirmed. The counter is reset.

In the **Last (4)** column, the date on which the corresponding maintenance work was last carried out is displayed.

The **Due (5)** column shows the time after how many months, beverages or litres the next maintenance work has to be carried out.

The **Back (6)** button takes you back to the Service menu.

	Last done	Due	
☺ Descaling	06/18/2024	in 6 months 571 litres	▶
☺ Maintenance 2	11/22/2023	39990 coffee beverages left	▶ <b>1</b>
☺ Maint. 24 months	11/22/2023	in 17 months	▶ <b>2</b>

Figure: Confirming maintenance

### Performing and confirming maintenance

2. Have the pending maintenance work carried out by a service technician.
3. Then tap on the displayed maintenance task **(1)** or **(2)** to confirm it.
  - ✓ The dialogue for the corresponding maintenance tasks opens.



Figure: Confirmation dialogue for completed maintenance work (example)

4. Make sure that maintenance has been carried out and completed in accordance with the maintenance concept and maintenance checklist.
5. Confirm the query with .
  - ✓ The maintenance work is displayed as completed on the **Maintenance intervals** screen (green smiley).
  - ✓ The date in the **Last** column changes to the current date.
  - ✓ The date in the **Due** column updates based on the set intervals.

### 10.1.3 Replacing external water filter (optional)



The external water filter must be replaced by an authorised service partner/service technician after the programmed number of litres is reached.



The **Water quality supplementary instructions** include information on recording the water values and using filter equipment. The supplementary instructions can be requested from Schaerer AG or downloaded directly from the Media Pool on the website (<http://www.schaerer.com/member>).

## 10.2 Descaling



### WARNING

#### Danger of acid burns!



Acid escapes during the descaling process. Danger of skin irritation and serious eye irritation

- ▶ Do not touch the descaling product with bare hands and read the enclosed safety data sheet.
- ▶ Do not remove the decalcification cartridge during the descaling process. Wait for the instruction on the display.



### CAUTION

#### Scalding danger due to hot water!

Hot water flows out of the hot water outlet and beverage outlet during descaling. This creates a danger of scalding.

- ▶ Pull the beverage outlet to the lowest dispensing position.
- ▶ Do not reach under the hot water outlet during the descaling process.



### CAUTION

#### Scalding danger due to hot steam!

The steam wand emits hot steam during cleaning and descaling. There is a danger of scalding.

- ▶ Guide the steam wand outlet into the drip tray.
- ▶ Do not reach under the steam wand during the cleaning and descaling process.

#### Descaling duration

A descaling process takes at least **85 minutes**. The machine is not ready for use during this time.

- ▶ Inform others in good time that the machine will not be ready for use.

#### Aborted descaling

The machine can only again be ready for use if the descaling programme has been correctly completed.

That is why repeating a descaling process that has not been fully and correctly completed is essential.

### 10.2.1 Required descaling material

- 1x Schaerer **Uptime!** SCSoul decalcification cartridge
- 1x Schaerer cleaning container 1 l blue
- 1x Schaerer cleaning container cover
- Gloves
- Protective goggles

## 10.2.2 Uptime! decalcification cartridge



### ADVICE

#### Property damage due to incorrect decalcification cartridge!

Use of decalcification cartridges other than those recommended by Schaerer AG may damage the coffee machine.

- ▶ Use only decalcification cartridges recommended by Schaerer AG.
- ▶ Only use cartridges taken directly out of the packaging.
- ▶ Before descaling, read the information on the packaging and the safety data sheet carefully. If a safety data sheet is not available, please request it from your sales partner.



Figure: **Uptime!** decalcification cartridge

Purpose:	Descaling of coffee machine with mains water supply
Scope of descaling:	Descaling the boiler including the hot water/steam system
Application interval:	As per request

### Preparation: Checking waste water outlet



### ADVICE

#### Risk of flooding!

A plugged waste water outlet causes the drip tray to overflow.

- ▶ Before the descaling process is done, check whether fluid is flowing freely through the waste water outlet.

The following are needed to check the waste water outlet:

- 1 l water
- Clock with second display

1. Remove the drip grid from the drip tray.
2. Fill 1 l of water into the drip tray and check the timer at the same time.
  - ✓ When the waste water outlet is not plugged, 1 l of water completely drains within 30 s.



If 1 l of water does not flow out in the required time of 30 s, the waste water outlet is blocked. Descaling must be done. The waste water outlet must first be repaired by a service technician.

### Starting descaling program

Prerequisite:

- The pending descaling process is displayed in the Service menu with a red smiley.

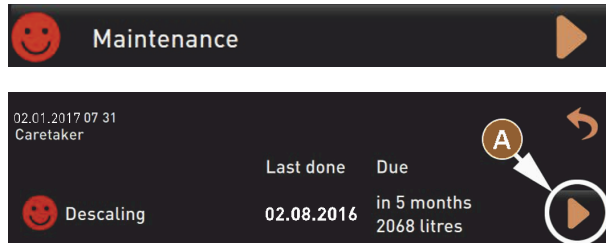

Figure: Descaling – opening maintenance

1. Tap on the button.
  - ✓ The Service menu is displayed.
2. Tap on the **Maintenance** button.
  - ✓ All executed and pending maintenance processes are displayed.
3. Tap on the **(A)** button on the **Maintenance** screen.
  - ✓ The descaling programme screen opens.
  - ✓ The **Check waste water outlet for blockage** instruction appears.



Figure: Unpacking decalcification cartridge

4. Remove the Schaerer **Uptime!** decalcification cartridge from the packaging.
5. Tap on the button for the next step.
  - ✓ The **Remove grounds container** instruction appears.



Figure: Checking waste water outlet

6. Check if the waste water outlet in the drip tray is clear  
 „Preparation: Checking waste water outlet“.

**INFORMATION:** The button in the display leads to the step-by-step description of a waste water outlet test.

7. Tap on the  button for the next step.
  - ✓ The **Remove grounds container** instruction appears.

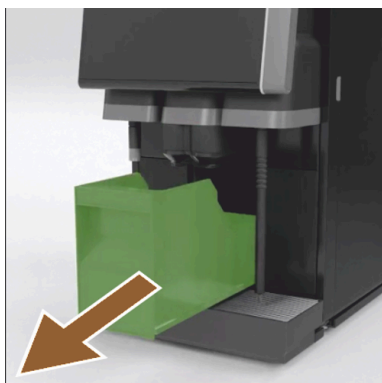

Figure: Remove the grounds container

8. Pull the grounds container out of the machine.
9. Empty and clean the grounds container.
  - ✓ The **Insert cartridge** instruction appears.

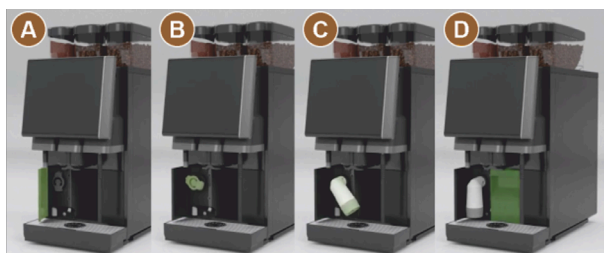

Figure: Opening cover

10. Open the cover **(A)** on the front left.
11. Remove the green sealing cap by turning it to the left **(B)**.
12. Fit the freshly unpacked cartridge and turn the cartridge to the right **(C)**.
  - ✓ The cartridge is inserted **(D)**.
  - ✓ The **Insert grounds container** instruction is displayed.

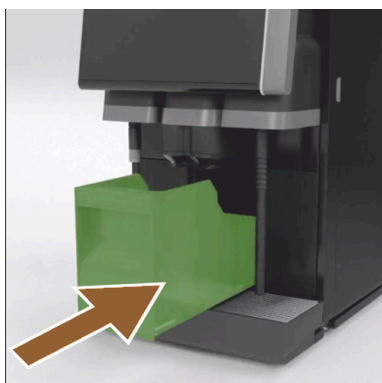

Figure: Inserting grounds container

13. Push the cleaned grounds container into the machine.
  - ✓ The **Remove milk container** (optional) instruction is displayed.



Figure: Removing milk container

14. Remove the milk container from the cooling unit. If necessary, empty and clean the milk container.

**ADVICE** Store the milk container with milk in a cool place during descaling.

15. Tap on the  button for the next step.

✓ The **Place cleaning container in cooling unit** instruction is displayed.



Figure: Placing the cleaning container in the cooling unit

16. Place the empty cleaning container in the cooling unit.

17. Insert the milk hose into the cover of the cleaning container.

18. Close the door of the cooling unit.

19. Tap on the  button for the next step.

✓ The **Position beverage outlet and steam wand** (optional) instruction appears.

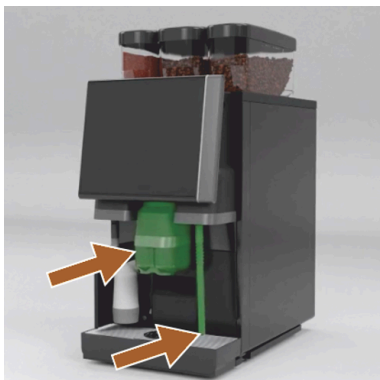



Figure: Removing cup platform

20. Remove the cup platform from the drip tray.

21. Move the manual beverage outlet to the lowest position.

22. Point the steam wand (optional) into the drip tray.

23. Tap on the  button for the next step.

- ✓ The **Read safety notes in the operating instructions** instruction appears.



The descaling process takes at least 85 min. The **Pause [II]** button interrupts descaling. The descaling programme can be interrupted up to step 8 with the **[X]** button.



Figure: Starting descaling

24. Start the descaling process with the **(A)**  button.

- ✓ The descaling progress is displayed in (%).
- ✓ The descaling process ends after approx. 85 min.
- ✓ **(A)** Cooling (blue) of the machine starts.
- ✓ **(B)** Descaling (yellow) is active.
- ✓ Rinsing (green) is active.

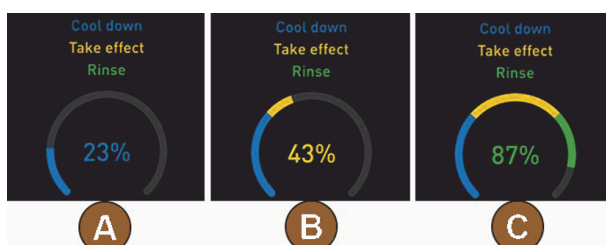

You can interrupt the descaling process with the **[II]** button and continue it with the  button.



**Warning** Wait for instruction in display before removing the decalcification cartridge.

Prerequisite:

- The descaling process is complete.
- The **Remove decalcification cartridge** instruction appears.

25. Remove the decalcification cartridge from the machine.

- ✓ The **Reattach protective cap** instruction appears.

26. Replace the green protective cap.

27. Close the left front cover.

28. Tap on the  button for the next step.

- ✓ The **Remove cleaning container** instruction appears.



Figure: Placing the cleaning container in the cooling unit

29. Pull the milk hose out of the cover of the cleaning container.

30. Remove the cleaning container from the cooling unit.

**ADVICE** Machine equipment with Twin Milk contains 2 milk hoses.

31. Tap on the  button for the next step.

- ✓ The **Insert milk container** instruction appears.



Figure: Removing milk container

32. Take the cleaning container out of the cooling unit.

33. Place milk container with cooled milk into the cooling unit.

34. Tap on the  button for the next step.

- ✓ The **Reorder decalcification cartridge** instruction appears.

Prerequisite:

- The article number appears in the user interface.

35. Reorder a cartridge from your service partner for the next descaling process.

36. Tap on the  button for the next step.

- ✓ The **Reorder decalcification cartridge** instruction appears.

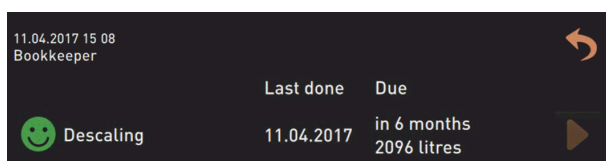

Figure: Descaling completed

- ✓ The descaling programme closes.
- ✓ The machine is restarted.
- ✓ Ready for use status and the user interface are displayed.
- ✓ The last descaling carried out is displayed in the Service menu under **Maintenance**.

### 10.2.3 Disposing of decalcification cartridge

The decalcification cartridge is made of plastic and must be completely drained and rinsed with water after descaling.

- After proper descaling, the decalcification cartridge must be disposed of as plastic waste or together with household waste.
- If descaling has been interrupted, the decalcification cartridge must be disposed of as hazardous waste in accordance with local regulations.

### 10.2.4 Decalcifying with ProCare



#### ADVICE

#### ProCare cleaning system

Detailed information on this topic can be found in the **ProCare** operating instructions.

# 11 Programming

## 11.1 Navigation elements

- ▶ Tap on the **Service menu**  button.
- ✓ The Service menu opens.

### User interfaces

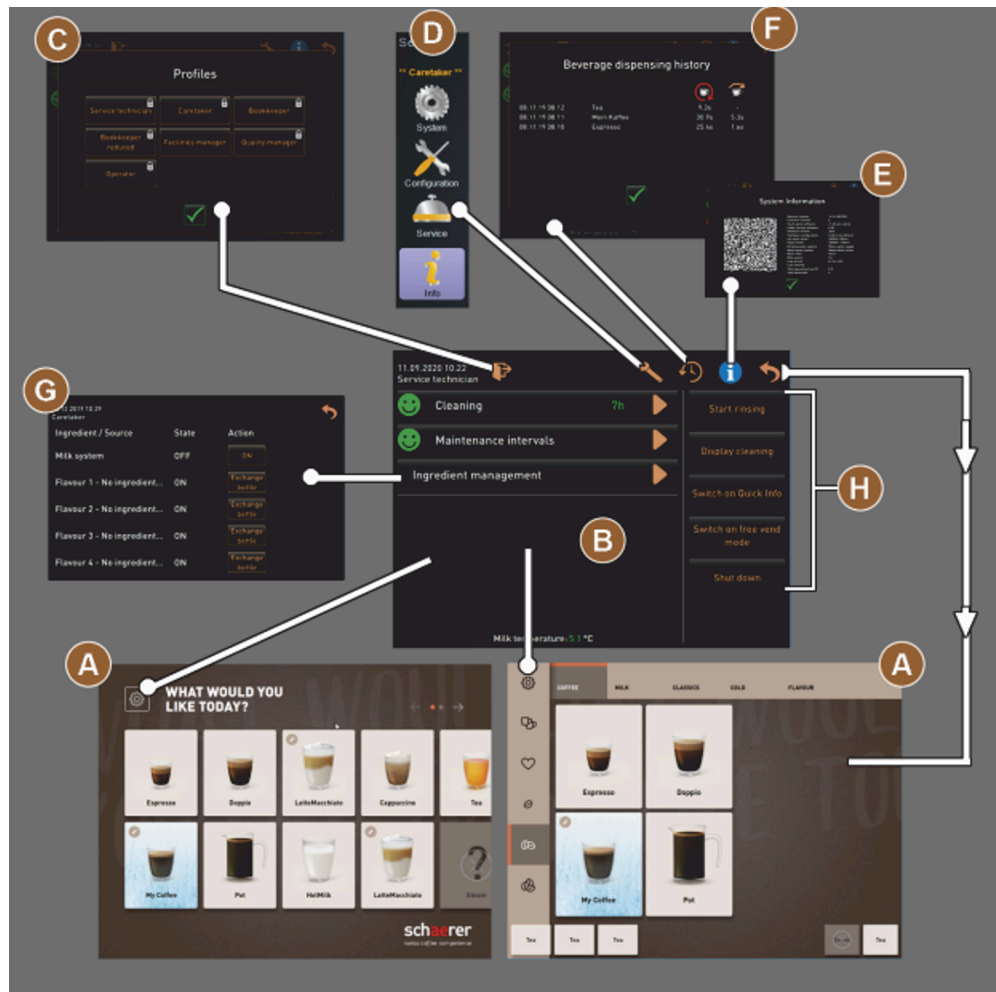

Figure: User interface navigation

- |  |   |
|--|---|
| <b>A</b> Beverage selection user interface (GUI) | <b>D</b> Machine configuration settings |
| <b>B</b> Navigation elements in the Service menu | <b>E</b> System information             |
| <b>C</b> Selection of activated profiles         | <b>F</b> Beverage dispensing history    |

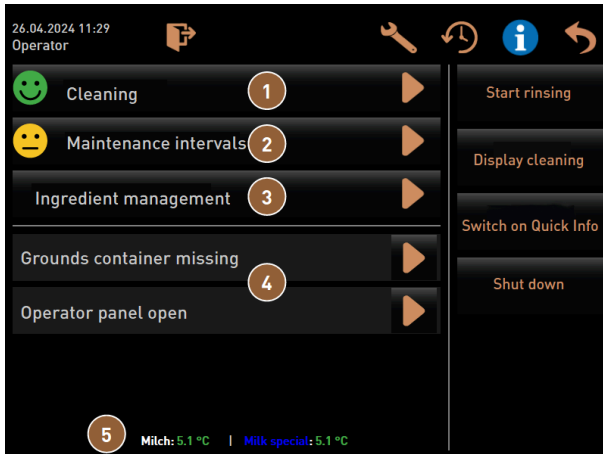















Figure: Service menu with maintenance and error status

- |   |  |   |                          |
|---|--|---|--------------------------|
| 1 | Cleaning status and start                | 4 | Pending error messages   |
| 2 | Maintenance status and start (descaling) | 5 | Current milk temperature |
| 3 | Ingredient management status and on/off  |   |                          |

Symbol	Designation	Description
	Entry into Service menu	The <b>Service menu</b> button on the user interface opens the <b>Service menu</b> screen. See 8.8 "Service menu"
	Back to beverage selection user interface	The <b>Back</b> button takes you back to the user interface with the beverage selection.
	System information	The <b>Info</b> button opens the system information window.
	Beverage dispensing history	The <b>Beverage dispensing history</b> button shows all beverages that have been dispensed. The following information is displayed for each beverage: <ul style="list-style-type: none"> <li>• Beverage dispensing duration</li> <li>• Beverage dispensing time</li> </ul>
	Main menu settings	The <b>Settings</b> button in the <b>Service menu</b> at the top right opens the window with the machine configuration parameters.
	Log in user profile	The <b>Log-in</b> button opens the dialogue for selecting the available profiles. The profiles have different access rights. <ul style="list-style-type: none"> <li>▶ Tap on <b>Log-in</b>. <ul style="list-style-type: none"> <li>✓ The dialogue for selecting a profile opens.</li> </ul> </li> <li>▶ Select a profile and enter a PIN if configured. <ul style="list-style-type: none"> <li>✓ The Service menu appears again.</li> <li>✓ The <b>Log-in</b> button changes to <b>Log-out</b>.</li> </ul> </li> </ul> <p>If a profile with corresponding authorisations is logged in, the <b>Settings</b> button is visible.</p>

Symbol	Designation	Description
	Log-out user profile	The <b>Log-out</b> button closes the currently logged in profile. The <b>Settings</b> button is no longer available.
	Machine configuration settings	<p>The machine configurations are divided into the following settings:</p> <ul style="list-style-type: none"> <li>• System</li> <li>• Configuration</li> <li>• Service</li> <li>• Info</li> </ul> <p>The parameters displayed here depend on the authorisations of the selected profile.</p> <p>All settings and configuration options are listed in the Service technician profile.</p> <p>► Tap on the button for a setting, e.g. <b>System</b>.</p> <ul style="list-style-type: none"> <li>✓ The currently active setting, e.g. <b>System</b>, is highlighted in colour.</li> <li>✓ The available settings are listed on the right-hand side of the screen.</li> </ul>
	Restart	The <b>Restart</b> button activates a restart of the coffee machine. A restart is required after the machine configurations have been changed.
	Configuration	The Configuration button opens the configuration window for: <ul style="list-style-type: none"> <li>• Ingredient sources</li> <li>• Beverages</li> <li>• Beverage step for specific settings</li> </ul>
	Activation/Confirmation	The <b>Activation/Confirmation</b> button confirms the selection of an assigned coffee type or temperature setting, for example.
	Cancel/Delete	The <b>Cancel/Delete</b> button has the following functions: <ul style="list-style-type: none"> <li>• Reset counter</li> <li>• Cancel beverage dispensing</li> <li>• Close window/page</li> </ul>
	Action request confirmation	The <b>Confirm</b> button can be used to confirm performed instructions for action.
	Next	The <b>Next</b> button opens a selection list or takes you to the next programme step.
	Back	The <b>Back</b> button takes you back to the previous window/page.
	Save	The <b>Save</b> button saves the parameter settings made.
	Copy	The <b>Copy</b> button copies an already configured beverage as a basis for additional beverage configurations.

Symbol	Designation	Description
	Add	The <b>Add</b> button adds beverages or beverage steps. The beverages are removed from the list of available beverages. The additional beverage is automatically added to the list of configured beverages.
	Beverage step configuration	The <b>Beverage step configuration</b> button takes you to the settings for the beverage configuration with the individual beverage steps.
	Open/Close structure tree	<b>(+)</b> expands the structure tree in the statistics. <b>(-)</b> reduces the structure tree in the statistics.
	Input field	The <b>Input field</b> can be used to enter the name for the beverage, beverage group, ingredients or for the menu cards using a displayed keyboard. Tapping on the input field opens the keyboard.
	Keyboard	Keyboard for entering text or numbers in the input field
	Parameter value	The <b>Parameter value</b> input field captures the value of a parameter. <b>Variant: Setting with control dial</b> <ol style="list-style-type: none"> <li>Tap on the parameter value.                             <ul style="list-style-type: none"> <li>✓ The control dial opens.</li> </ul> </li> <li>Set the desired value by turning the control dial up and down.</li> <li>Confirm the set value with .</li> </ol> <b>Variant: Setting with keyboard</b> <ol style="list-style-type: none"> <li>Tap on the field containing the current setting <b>(A)</b>.                             <ul style="list-style-type: none"> <li>✓ The keyboard entry opens.</li> <li>✓ Min. and max. values of the possible settings are displayed <b>(B)</b>.</li> </ul> </li> <li>Delete the current setting with button <b>(D)</b>.                             <ul style="list-style-type: none"> <li>✓ The numeric keypad is activated.</li> </ul> </li> <li>Enter the new value using the keyboard <b>(C)</b>.</li> <li>Confirm the value with the <b>(E)</b> button.</li> </ol>
	On/Off function	The <b>On/Off</b> switch activates or deactivates a function. Lit up green = On Matt grey - Off

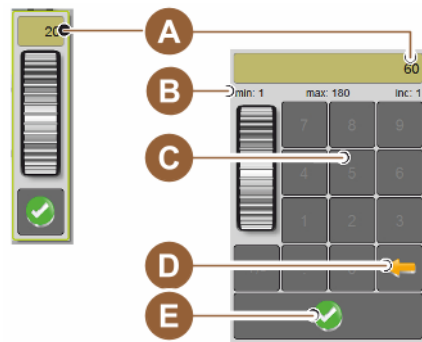



Figure: Input of parameter value using keyboard

Symbol	Designation	Description
	Arrow down, arrow up value setting	<p>The date and time values are set using the <b>down arrow</b> or <b>up arrow</b> buttons.</p> <ol style="list-style-type: none"> <li>1. Tap on the value to be set. <ul style="list-style-type: none"> <li>✓ The value is marked.</li> </ul> </li> <li>2. Change the highlighted value with the <b>arrow down/up</b> button. <ul style="list-style-type: none"> <li>✓ The time or date is set.</li> </ul> </li> <li>3. Tap on the <b>Save</b> button. <ul style="list-style-type: none"> <li>✓ The settings are active.</li> </ul> </li> </ol>

## 11.2 USB interface

In the machine, software updates, data storage or data exchange are performed using a USB stick. The USB port is located behind the user panel.

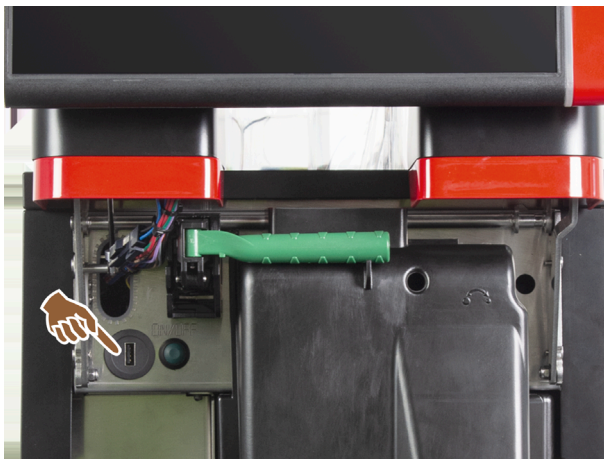

Figure: Position of the USB interface

- ▶ Unlock the user panel and slide it upwards until it automatically engages.
  - ✓ The USB port is located to the left of the On/Off button.

See 8.1.6 "Opening and closing user panel".

## 11.3 Profiles and authorisations

Profiles are used to manage different activities with the machine and the authorisations required for them.

### 11.3.1 Caretaker profile

The caretaker is the first person to contact in the event of technical problems. He or she possesses sound technical knowledge and works regularly with the machine.

Except for the service technician, the caretaker has access to the most service functions.



### Functions in the Service menu

In the **Caretaker** profile, the following functions are available for direct selection in the Service menu:

- Start rinsing
- Touch screen cleaning
- Switch quick info on/off
- Switch-off
- Cleaning
- Maintenance intervals
- Ingredient management



### Settings

The following settings can be changed in the **Caretaker** profile:

- System
- Configuration
- Service
- Info

## 11.3.2 Bookkeeper profile

The Bookkeeper and Bookkeeper reduced profiles have limited service functions.



### Functions in the Service menu

In the **Bookkeeper** profile, the following functions are available for direct selection in the Service menu:

- Start rinsing
- Touch screen cleaning
- Switch quick info on/off
- Switch on Free vending mode if there is a payment system (bookkeeper)
- Switch-off
- Start maintenance (descaling)
- Ingredient management



### Settings

The following settings can be changed in the **Bookkeeper** profile:

- Configuration
- Info



See 8.8.4.3 "Access to the Profiles dialogue"

### 11.3.3 Facilities manager profile

The facilities manager is a department or restaurant manager and his or her duties also include administrative activities.

The facilities manager has access to some statistics of the machine to get an overview of the type and quantity of beverages served.

The facilities manager has limited access to the service functions. He or she has more statistics at its disposal than the quality manager and the machine operator.



#### Functions in the Service menu

In the **Facilities manager** profile, the following functions are available for direct selection in the Service menu:

- Start rinsing
- Touch screen cleaning
- Switch quick info on/off
- Switch-off
- Maintenance intervals
- Ingredient management



#### Settings

The following settings can be changed in the **Facilities manager** profile:

- Configuration
- Info

### 11.3.4 Quality manager profile

The quality manager is responsible for the quality of the beverages from the machine. Monitoring cleaning times is particularly important to ensure quality.

The quality manager has limited access to the service functions. The quality manager has more statistics at its disposal than the machine operator.



#### Functions in the Service menu

In the **Quality manager** profile, the following functions are available for direct selection in the Service menu:

- Start rinsing
- Touch screen cleaning
- Switch quick info on/off
- Switch-off
- Maintenance intervals
- Ingredient management



### Settings

The following settings can be changed in the **Quality manager** profile:

- Configuration
- Info

## 11.3.5 Machine operator profile

The machine operator is the normal operator of the machine and therefore only a few service functions are available in this profile. Apart from setting the language, the machine operator can view the machine version in order to pass on the information to a service technician when errors occur.



### Functions in the Service menu

In the **Machine operator** profile, the following functions are available for direct selection in the Service menu:

- Start rinsing
- Touch screen cleaning
- Switch quick info on/off
- Switch-off
- Cleaning
- Maintenance intervals
- Ingredient management



### Settings

The following settings can be changed in the **Machine operator** profile:

- Configuration
- Info

## 11.4 Machine configuration

### 11.4.1 "System" settings

You can make the following settings on the **System** setting screen:

- **Grinder/Brewing unit** system setting
- **Milk system** system setting
- **Flavour Point** system setting (option)

- ▶ Tap on the **System**  button.
  - ✓ The **System** setting screen opens.

#### **Grinder/Brewing unit system setting**

The **Grinder / Brewing unit** setting opens the following menu points for system settings and displays:

- Grounds container: Capacity
- Grounds container: Emptying time [s]

- Grounds container: Current counter
- Centre grinder calibration value (10 s) [g]
- Right grinder calibration value (10 s) [g] (option)
- Left grinder calibration value (10 s) [g] (option)

#### Authorised profiles

- Service technician
- Caretaker



Figure: Screen with settings for grinder/brewing unit

#### Grounds container: Capacity

With this setting, the number of cycles (coffee cakes) until the **Empty grounds container** message appears is defined.

Setting range	Standard
0 – 150 coffee cakes	60 coffee cakes

1. Standard: Set the value to 60 coffee cakes. Do not exceed this value.
  - ✓ The coffee machine blocks dispensing of coffee beverages after 65 brewing cycles (+ 5) until the grounds container is emptied.
2. With grounds disposal (option): Set the value to 0 coffee cakes.
  - ✓ The number of cycles (coffee cakes) is ignored.

#### Grounds container: Emptying time [s]

This setting defines the period of time until the current grounds container counter is reset to 0 after emptying.

Setting range	Standard
0 – 30 s	5 s

1. Set the value to 5 s.
2. Empty the grounds container when the corresponding instruction is shown in the display. If the grounds container is only briefly pulled out and immediately pushed back in, the counter value is retained and it is not reset.
3. Do not reinsert the emptied grounds container for at least 5 s.
  - ✓ The **Current grounds container counter** is reset to 0.

### Grounds container: Current counter

The display provides information on the brewing cycles executed since the last time the grounds container was emptied. If the preset value for the capacity of the grounds container is reached, the instruction for emptying the grounds container appears.

This menu item is purely a display in the **Caretaker** profile. Settings are not possible.

### Centre grinder calibration value (10 s) [g]

The calibration value in grams is recorded with this setting for the centre grinder during grinder calibration.

Service technicians can change the value.

Setting range	Standard
1.0 – 50.0 g	Calibration executed accordingly

1. Start calibration in the **Service – Grinder service** setting.
2. Execute calibration using the assistant.
3. Enter the calculated value in this input field (only in the **Service technician** profile).
  - ✓ Grinder calibration for the centre grinder is complete.
  - ✓ The output grind quantity corresponds to the grind quantity set in the coffee recipe.

**ADVICE** Service technicians can change the calibration value in grams displayed in this parameter for a blanket adjustment of the coffee beverages from the centre grinder without calibrating the grinder. Adjusting the calibration value influences all coffee recipes which were assigned to the centre grinder.

### Right grinder calibration value (10 s) [g] (option)

The process is the same as for the centre grinder.

### Left grinder calibration value (10 s) [g] (option)

The process is the same as for the centre grinder.

### Milk system setting

The **Milk system** setting opens the following menu points for system settings and displays:

- Milk container
- Milk 1 hose length from squeeze valve -> cooling cell [cm]
- Milk 2 hose length from squeeze valve -> cooling cell [cm]
- Milk level monitoring

Authorised profiles

- Service technician
- Caretaker

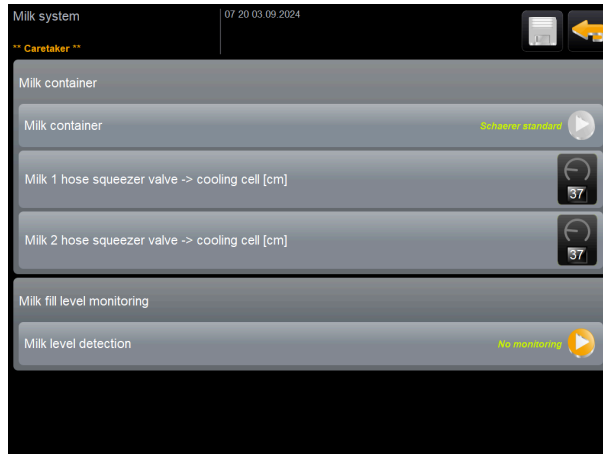

Figure: Screen with settings for milk system

### Milk container

This setting is used to record the milk hose length up to the milk container. The setting refers to the effective milk hose length with or without riser pipe in the milk container.

Service technicians can change the value.

Setting range	Standard
<b>Custom</b> or <b>Schaerer standard</b> (only to be set by a service technician)	<b>Schaerer standard</b>

#### Custom

1. Select the **Custom** option (only in the **Service technician** profile).
  - ✓ The milk hose is not automatically detected.
2. Measure the exact milk hose length from the milk container to the squeeze valve in the machine and record the value calculated for **Milk 1 hose length from squeeze valve -> cooling cell [cm]**.

#### Schaerer standard

- ▶ Select the **Schaerer standard** option (only in the **Service technician** profile).
  - ✓ The milk hose length is automatically detected.
  - ✓ The standard setting of *37 cm* in the following parameter does not require any additional adaptation.

See below the description for the **Milk 1 hose length from squeeze valve -> cooling cell [cm]** parameter.

### Milk 1 hose length from squeeze valve -> cooling cell [cm]

This setting is used to record the milk hose dimension from the squeeze valve to the cooling cell for the external milk hose.

Service technicians can change the value.

Setting range	Standard
<i>0 – 200 cm</i> (only to be set by service technicians)	<i>37 cm</i> (with the <b>Schaerer standard</b> option)

If the **Custom** option is selected in the previous **Milk container** parameter, the exact milk hose length can be entered in the **Service technician** profile.

#### For service technicians

1. Measure the milk hose length from squeeze valve in the machine up to the milk container in the cooling device.

2. Record the calculated value for the **Milk 1 hose length from squeeze valve -> cooling cell [cm]** parameter.
  - ✓ The system now knows the milk hose length.
  - ✓ The correct milk quantity is periodically exchanged for the **rinsing interval of external milk hose**.

With the standard equipment of the **left side cooling unit**, the **Schaerer standard** option is selected in the **Milk container** parameter. This setting corresponds to the correct milk hose length of *37 cm*.

The following milk systems require the **Custom** option:

- Left cooling unit of the coffee machine
- Cooling unit with Twin Milk
- Under-counter cooling unit
- Under-machine cooling unit
- All optional accessories, e.g. Cup & Cool and Centre Milk

### Milk 2 hose length from squeeze valve -> cooling cell [cm]

This setting is used to record the milk hose dimension from the squeeze valve to the cooling cell for the second milk hose for the **Twin Milk**.

Service technicians can change the value.

Setting range	Standard
<i>0 – 200 cm</i> (only to be set by service technicians)	<i>37 cm</i> (with the <b>Schaerer standard</b> option)

The process corresponds to that for the **Milk 1 hose length from squeeze valve -> cooling cell [cm]**.

### Milk level monitoring

This setting defines the fill level monitoring behaviour for the milk container.

Setting range	Standard
No monitoring Warning Disable beverage dispensing	No monitoring

#### No monitoring option

- Milk monitoring is configured but is not in use.

#### Warning option

- If a low milk level is detected, a message appears on the display. Other milk beverages can be dispensed.

#### Disable beverage dispensing option

- If a low milk level is detected, a message appears on the display. Dispensing of milk beverages is blocked.

### Flavour Point system setting (option)

The **Flavour Point** setting opens the following menu points for system settings and displays:

- Syrup level monitoring

Authorised profiles

- Service technician
- Caretaker

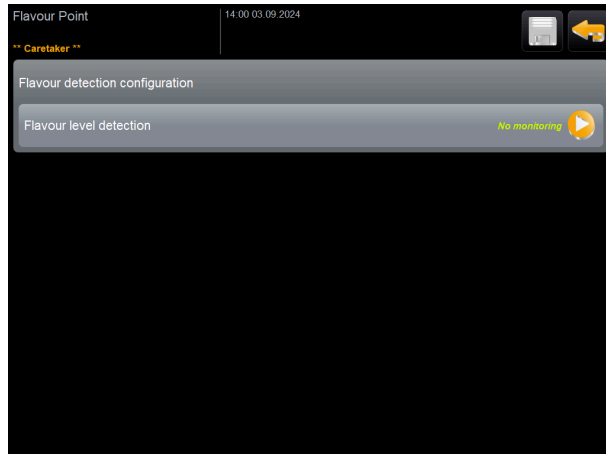

Figure: Screen with settings for Flavour Point

### Flavour Point level monitoring

This setting defines the fill level monitoring behaviour for Flavour Point syrup bottles.

Setting range	Standard
No monitoring	No monitoring
Warning	
Disable beverage dispensing	

#### No monitoring option

- Syrup monitoring is configured but is not in use.

#### Warning option

- If a low fill level is detected in the syrup bottle, a message appears on the display. Other beverages containing aromas can be dispensed.

#### Disable beverage dispensing option

- If the fill level in the syrup bottle is low, a message appears on the display. Dispensing of beverages containing flavour is blocked.

## 11.4.2 "Configuration" settings

Authorised profiles: Caretaker, facilities manager, bookkeeper, bookkeeper reduced, machine operator and quality manager

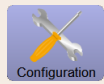

**Setting > Configuration – General**

Main language



Figure: Display language

Changes the display language.

Setting range: All provided languages

Standard: Free selection

1. Open the language setting with the button.
  - ✓ The selection menu appears.
2. Select the desired language.
  - ✓ All display messages and parameter names appear in the activated language.

See 11.4.5 "Saving changes and loading them into the machine".

Authorised profiles: Caretaker

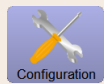

**Setting > Configuration – Time/Date/Timer operation**

Date

Time

Time zone

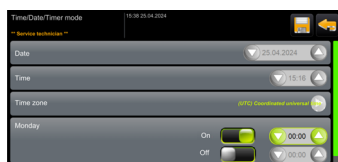
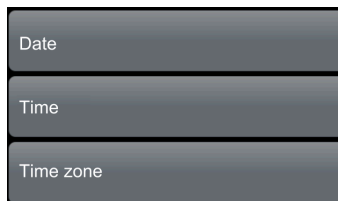

Shows information about the preset time zone with date and time.

Setting range: No setting possible

Default: Country-specific/User-specific

The time zone is selected while the commissioning programme is running. When the time zone is set, the time and date from the selected time zone are applied.

Available time zones:

- Asia
- Africa
- Australia
- Europe
- North America
- South America

Each time zone contains further subdivisions, e.g. *Central European Time (CET/MEZ)*.

Monday On/Off to

Sunday On/Off

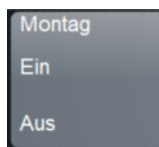

Shows information about the automatic switch-on/switch-off times.

Setting range: Day/Switch-on time/Switch-off time/Time

Standard: User-specific

1. Activate the switch-on time for the desired day of the week using the switch.
  - ✓ The settings for the time become active.
2. Set the time using the buttons, e.g. 07:00 (07:00 a.m.).
3. Activate the switch-off time for the desired day of the week using the switch.
  - ✓ The settings for the time become active.
4. Set the time using the buttons, e.g. 22:30 (10:30 p.m.).

Depending on the selected time zone, the respective time format (24 h or 12 h AM/PM) is automatically selected.

Authorised profiles: Bookkeeper, facilities manager

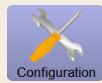

### Setting > Configuration – Beverage price adjustment by the bookkeeper (standard operating mode)

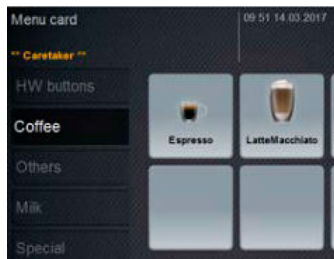

Figure: Beverages in menu card

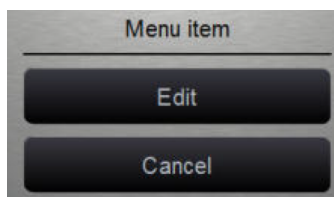



Figure: Menu item



Figure: Beverage price menu item

#### Beverage price setting with or without payment system

Prerequisite: The **Configuration – Operating mode – Menu card** setting contains the **Standard** setting.

1. Open the Service menu.
2. Log in with the **Bookkeeper** or **Service technician** profile.
3. Open the settings with .
4. Select the **Configuration – menu card** setting.
  - ✓ The **Standard** menu card opens.
5. Select the desired beverage.
  - ✓ The **Menu item** context menu opens.
6. Tap on the **Edit** button.
  - ✓ The **Menu card entry** window opens.
  - ✓ The individual beverage sizes are listed separately according to the beverage configuration.
7. Tap on the **Edit**  button for the desired beverage size.
8. Enter the required beverage prices in the **(0)**, **(1)**, **(2)**, and/or **(3)** price lists in the input field.

See below under **Price setting using the setting dial**.

Authorised profiles: Bookkeeper, facilities manager

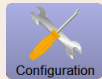

### Setting > Configuration – Beverage price adjustment by the bookkeeper (custom operating mode)

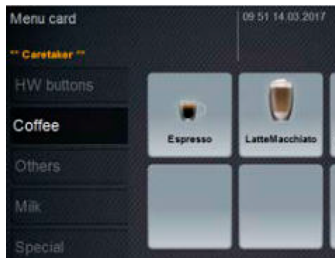

Figure: Beverages in menu card

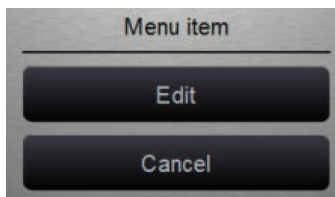

Figure: Menu item





Figure: Beverage price menu item





Figure: Beverage price input field with control dial

#### Beverage price setting with or without payment system

Prerequisite: The **Configuration – Operating mode – Menu card** setting contains the **Custom** setting.

1. Open the Service menu.
2. Log in with the **Bookkeeper** or **Service technician** profile.
3. Open the settings with .
4. Select the **Configuration – menu card** setting.
  - ✓ The **Custom** menu card opens.
5. Open the desired menu card from the list.
  - ✓ The menu card opens.
6. Tap on the **Edit** button.
  - ✓ The **Menu card entry** window opens.
  - ✓ The individual beverage sizes are listed separately according to the beverage configuration.
7. Tap on the **Edit**  button for the desired beverage size.
  - ✓ The **Edit menu card entry** screen opens.
8. Enter the required beverage prices in the **(0)**, **(1)**, **(2)**, and/or **(3)** price lists in the input field.

#### Setting price using control dial

1. Tap on the input field.
  - ✓ The dialogue with the setting dial opens.
2. Enter the required value using the setting dial or the keyboard.
3. Save the setting with  and navigate back to the menu card or user interface with .
  - ✓ The beverage is now displayed in the user interface with the set price.
  - ✓ The beverage price changes when the beverage selection, cup or mug size is changed.

During beverage selection, the beverage price is always updated according to the options selected later.



Beverage selection can be cancelled at any time before payment with the **[X]** button. If the beverage has already been paid for, it is no longer possible to cancel the order.

## 11.4.3 "Service" settings

You can make the following settings on the **Service** setting screen:

- **Grinder service** setting
- **Back up database** service setting

- **Reset descaling counter** service setting
  - **Reset descaling** service setting
  - **Reset cleaning** service setting
- ▶ Tap on the **Service**  button.
- ✓ The **Service** setting screen opens.

### Grinder service setting (manual grinding level adjustment)

The **Grinder service** setting (for manual grinding level adjustment) starts the following display-guided service functions on the grinder after confirmation:

- Grinding disc replacement
- Grinder adjustment
- Grinder calibration

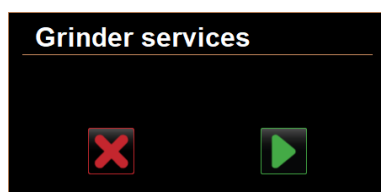



Figure: Starting grinder service

**Prerequisite:** The machine is equipped with manual grinder adjustment.

1. Tap on the **Service** → **Grinder service** setting.
  - ✓ The confirmation dialogue opens.
2. Confirm with .
  - ✓ The service functions for the grinders are available.
3. Open the tab for the desired grinder (left, right, centre).

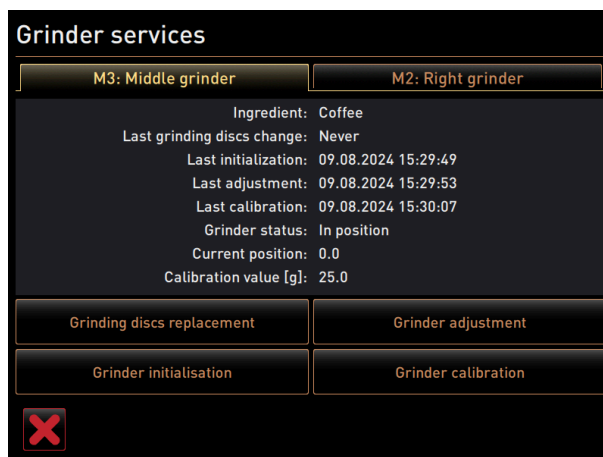

Figure: Screen for grinder service

### Grinding disc replacement



#### WARNING

#### Cutting injuries!

Danger of injury from the rotating grinding discs in the grinder.

- ▶ Never reach into the bean hopper when the coffee machine is switched on.

To replace the grinding discs, the following steps are required:

1. Tap on the **Change grinding discs** button.
  - ✓ The instruction prompting you to replace the grinding disc appears.
2. Switch off the machine and disconnect it from the mains.
3. Remove the manual grinding level adjustment and install new grinding discs.
4. Close the empty grinder by hand until resistance can be felt (grinding disc against grinding disc).
5. Open the grinder 45° anticlockwise.
6. Reassemble the manual grinding level adjustment.
7. Switch the machine back on and navigate to the **Grinder service** screen.
8. Confirm the **Change grinding discs** installation steps with the  button.
  - ✓ The preparation steps for **Preparing grind level adjustment** appear.

### Grinder adjustment

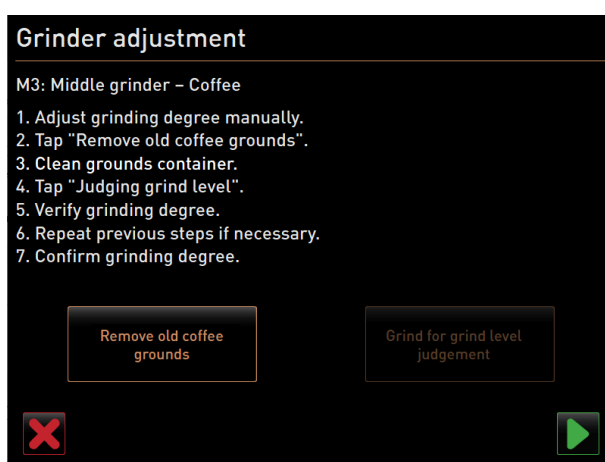



Figure: Adjusting grinder: Removing old ground coffee

#### Steps: Grinder adjustment

1. Continue the settings steps after **Grinding disc replacement** or tap directly on the **Adjust grinder** button.
  - ✓ The preparation steps for **Preparing grind level adjustment** appear.
2. Empty and clean the grounds container and reinsert it.
3. Confirm that the grounds container is inserted with the  button.
4. Set the grinding level manually.
5. Tap on the **Remove old ground coffee** button.
  - ✓ The old ground coffee is removed.

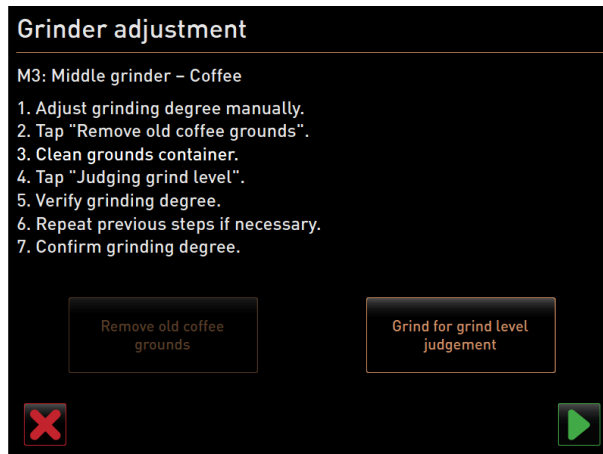



Figure: Grinder adjustment: Grind for grind level evaluation

- ✓ The **Grind for grind level evaluation** button becomes active.
- 6. Clean the grounds container again.
- 7. Tap on the **Grind for grind level evaluation** button.
  - ✓ Grinding is carried out.
- 8. Check the grinding level and repeat the steps for setting the grinding level if necessary or confirm the set grinding level with the  button.
  - ✓ The preparation steps for calibrating the grinder are displayed.

### Grinder calibration

**Prerequisite:** Calibration is required in the following cases:

- The machine is new.
- The operating time is more than one year.
- The grinding level has been changed.
- The grinder is open.
- The grinding discs have been replaced.
- The coffee type has been changed.

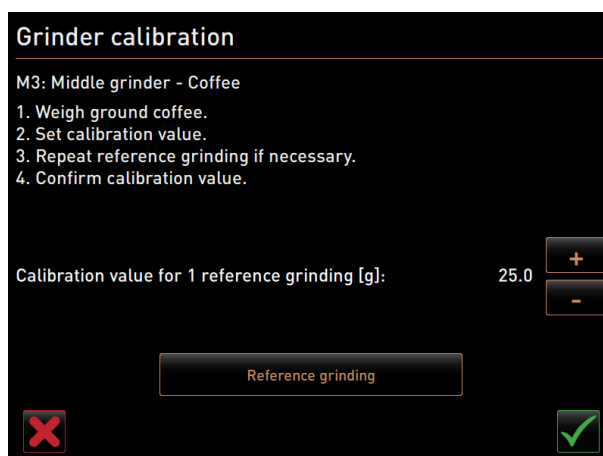



Figure: Grinder calibration

**Steps:** Grinder calibration

1. Continue the settings steps after **Grinder adjustment** or tap directly on the **Calibrate grinder** button.
  - ✓ The preparation steps for calibration are displayed.
2. Empty and clean the grounds container and reinsert it.

3. Confirm that the grounds container is inserted with the  button.
  - ✓ Reference grinding starts.
4. If needed, start additional reference grinding with the **Reference grinding** button.
5. If several reference grinding operations are performed, always weigh the entire resulting quantity of ground coffee and enter the amount as a reference value.
  - ✓ The machine automatically detects all the grinding operations triggered and calculates the correct grind quantity from this.
6. Weigh the ground coffee of the reference grind.
7. Set the calibration value (determined weight of ground coffee) using the **Plus** or **Minus** button.
8. Confirm calibration of the grinder with the  button.
  - ✓ The **Grinder service** screen opens.
  - ✓ The set grinder is ready for use.

### Grinder service setting (automatic grinding level adjustment)

The **Grinder service** setting (for automatic grinding level adjustment) starts the following display-guided service functions on the grinder after confirmation:

- Grinding disc replacement
- Grinder adjustment
- Grinder initialisation
- Grinder calibration

The grinder services for automatic grinder adjustment also require grinder initialisation as well as grinder adaptation via the grind level motors.

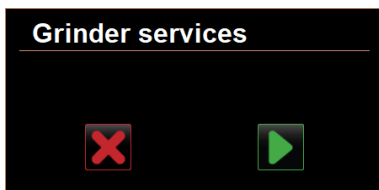

Figure: Starting grinder service

**Prerequisite:** The machine is equipped with an automatic grinder adjustment.

1. Tap on the **Service → Grinder service** setting.
  - ✓ The confirmation dialogue opens.
2. Confirm with .
  - ✓ The service functions for the grinders are available.
3. Open the tab for the desired grinder (left, right, centre).



Figure: Screen for grinder service

## Grinding disc replacement



### WARNING

#### Cutting injuries!

Danger of injury from the rotating grinding discs in the grinder.

- ▶ Never reach into the bean hopper when the coffee machine is switched on.

To replace the grinding discs, the following steps are required:

1. Tap on the **Change grinding discs** button.
  - ✓ The instruction prompting you to replace the grinding disc appears.
2. Switch off the machine and disconnect it from the mains.
3. Remove the grinder level motor and install new grinding discs.
4. Close the empty grinder by hand until resistance can be felt (grinding disc against grinding disc).
5. Open the grinder 45° anticlockwise.
6. Reassemble the grinding level motor.
7. Switch the machine back on and navigate to the **Grinder service** screen.
8. Confirm the **Change grinding discs** and **Grinder initialisation** installation steps with the  button.
  - ✓ The preparation steps for **Preparing grind level adjustment** appear.

## Grinder adjustment

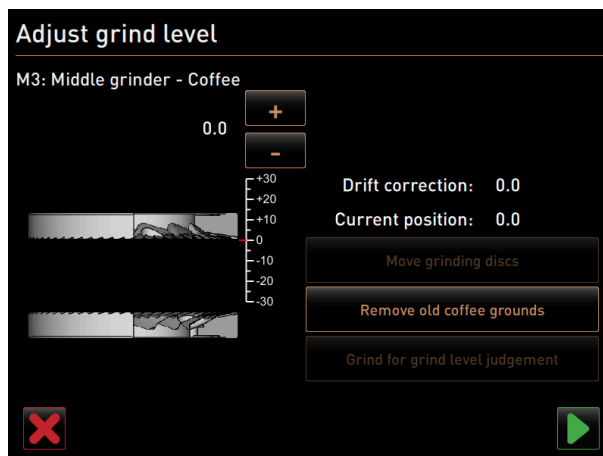



Figure: Adjusting grinder: Removing old ground coffee

### Steps: Grinder adjustment

1. Continue the settings steps after **Grinding disc replacement** or tap directly on the **Adjust grinder** button.
  - ✓ The preparation steps for **Preparing grind level adjustment** appear.
2. Empty and clean the grounds container and reinsert it.
3. Confirm that the grounds container is inserted with the  button.
4. Tap on the **Remove old ground coffee** button.
  - ✓ The old ground coffee is removed.

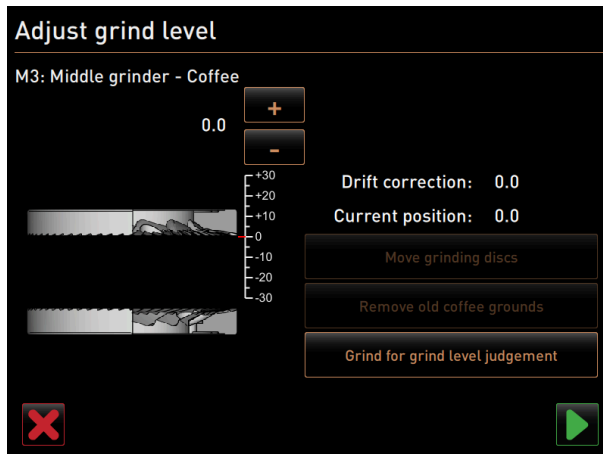

Figure: Grinder adjustment: Grind for grind level evaluation

- ✓ The **Grind for grind level evaluation** button becomes active.
5. Clean the grounds container again.
  6. Tap on the **Grind for grind level evaluation** button.
    - ✓ Grinding is carried out.

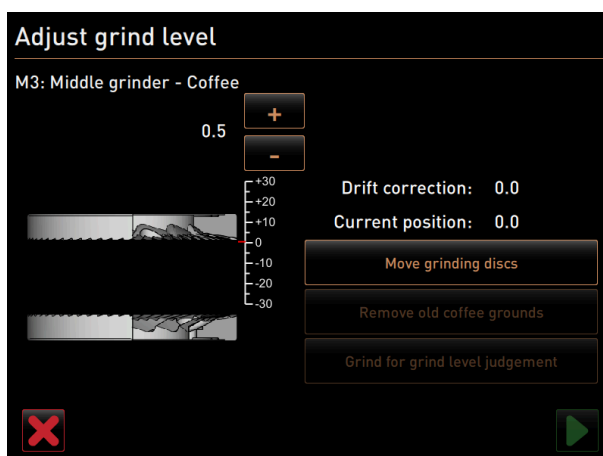



Figure: Grinder adjustment: Moving grinding discs

7. Adjust the grinding level result with the **Plus** = coarser or **Minus** = finer button.
8. Make grinding level adjustments in small steps  $\pm 1$ .
9. Use the **Move grinding disc** button to set the blade to the previously set position.
10. Check the grinding level and repeat the steps for setting the grinding level if necessary or confirm the set grinding level with the  button.
  - ✓ The preparation steps for calibrating the grinder are displayed.

### Grinder calibration

**Prerequisite:** Calibration is required in the following cases:

- The machine is new.
- The operating time is more than one year.
- The grinding level has been changed.
- The grinder is open.
- The grinding discs have been replaced.
- The coffee type has been changed.

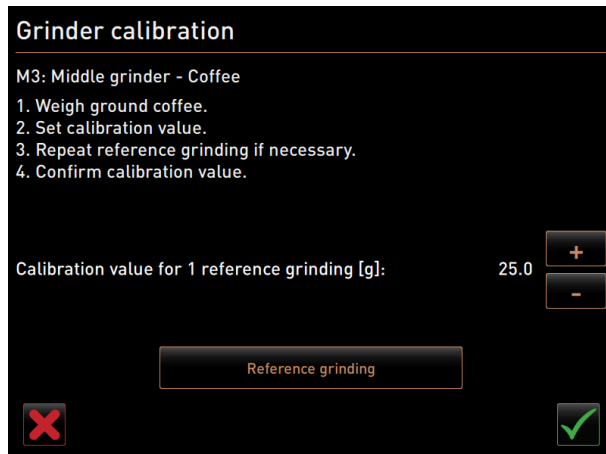



Figure: Grinder calibration

**Steps:** Grinder calibration

1. Continue the settings steps after **Grinder adjustment** or tap directly on the **Calibrate grinder** button.
  - ✓ The preparation steps for calibration are displayed.
2. Empty and clean the grounds container and reinsert it.
3. Confirm that the grounds container is inserted with the  button.
  - ✓ Reference grinding starts.
4. If needed, start additional reference grinding with the **Reference grinding** button.
5. If several reference grinding operations are performed, always weigh the entire resulting quantity of ground coffee and enter the amount as a reference value.
  - ✓ The machine automatically detects all the grinding operations triggered and calculates the correct grind quantity from this.
6. Weigh the ground coffee of the reference grind.
7. Set the calibration value (determined weight of ground coffee) using the **Plus** or **Minus** button.
8. Confirm calibration of the grinder with the  button.
  - ✓ The **Grinder service** screen opens.
  - ✓ The set grinder is ready for use.

**Grinder initialisation**

**Prerequisite:** The grinder must be initialised in the following cases:

- After a malfunction
- After the grinding discs have been replaced, the automatic grind level adjustment must be initialised.

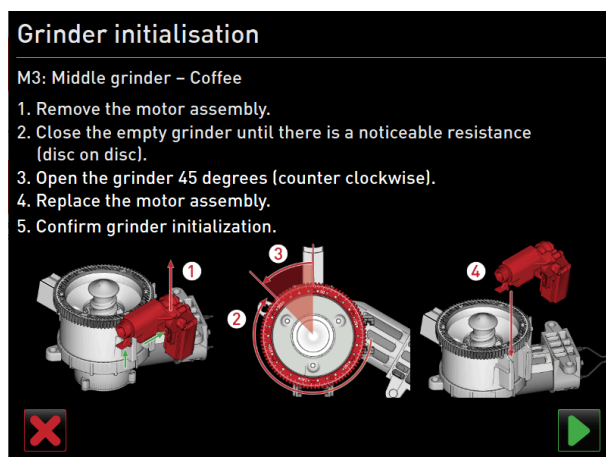



Figure: Grinder initialisation

**Steps: Grinder initialisation**

1. Follow the displayed instructions.
2. Remove the grinder level motor and install new grinding discs.
3. Close the empty grinder by hand until resistance can be felt (grinding disc against grinding disc).
4. Open the grinder 45° anticlockwise.
5. Reassemble the grinding level motor.
6. Confirm the **Grinder initialisation** installation steps with the  button.

**Back up database****ADVICE****Property damage due to data loss**

The touch screen contains an SD memory card for storing the machine data.

- ▶ Back up the database on a USB data carrier before carrying out an update.
- ▶ Back up the database on a USB data carrier before replace the touch screen.
- ▶ Insert the previously used SD memory card into the new touch screen. This ensures that the system is immediately ready for use.

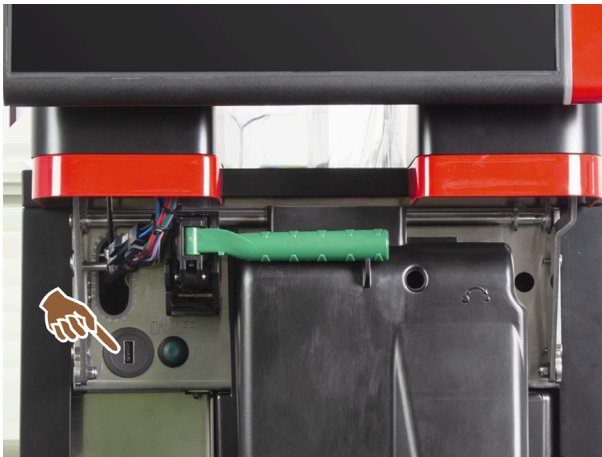

Figure: Position of the USB interface

**Steps: Back up database**

1. Lift the user panel.
2. Insert the USB data carrier into the USB interface.
3. Tap on the **Service -> Back up database** setting.
  - ✓ The machine database is saved onto the USB stick.
  - ✓ The saved database version is compatible with the installed machine software version.
4. Remove the USB data carrier when the **Data backup complete** message appears on the display.
5. Close the user panel.

The database is saved on the USB data carrier under  
*Schaerer/SCA3/backup/database/sca3db.db3\_<yyyymmdd\_hhmmss>*

The database is automatically saved on the SD memory card inserted in the touch screen every 5 min. It is also saved directly in the system at the same time.

With a **downgrade**, the database version saved on the USB data carrier is again compatible with the older machine software.

The following data is stored on the USB data carrier:

- Machine number
- Beverage recipes
- Hardware configuration
- All beverage counters

### Resetting descaling counters



#### ADVICE

#### Property damage due skipped descaling operations!

Skipping descaling can lead to damage and malfunctions.

- ▶ Carry out descaling operations which are not performed automatically because the counter has been reset as soon as possible and start them manually.

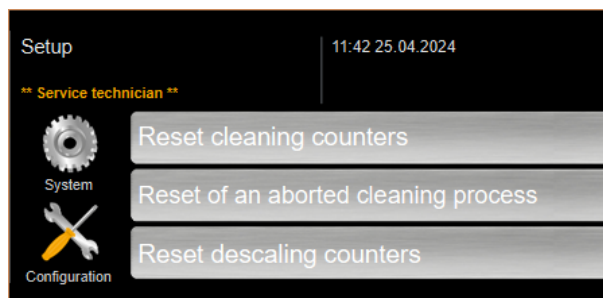

Figure: Buttons for resetting

The parameter disables a pending descaling operation.

1. Tap on the **Service -> Reset descaling counter** setting.
2. Confirm that the process with the  button.
  - ✓ The descaling counter is reset and any pending descaling operation is deleted.
  - ✓ The next automatic descaling operation is performed in line with what has been configured in the **System - Maintenance** setting.

### Resetting cleaning/descaling

A cleaning or descaling programme can be interrupted using the  button. A power failure also leads to interruption of any cleaning or descaling operation that is in progress.

After cleaning or descaling is aborted, the status of the machine remains in the **Cleaning** or **Descaling** mode. In order to leave the mode, it is necessary to reset the cleaning or descaling flag.

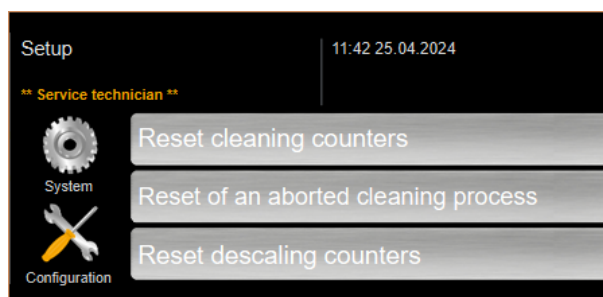

Figure: Buttons for resetting

Delete the cleaning or descaling flag. Any aborted cleaning or descaling operation is reset.

1. Tap on the **Service -> Resetting descaling / cleaning** setting.
2. Confirm that the process with the  button.
  - ✓ The cleaning and descaling flag is reset and any pending descaling operation is deleted.

- ✓ The next automatic cleaning or descaling operation is only performed in line with what has been configured in the **"System – Cleaning and System – Maintenance"** setting.
- 3. It is absolutely essential to restart cleaning or descaling right away.

#### 11.4.4 "Info" settings



This information must be passed on to the service technician when reporting an error.

**Setting > Info – Show versions**

---

Authorised profiles:

Function:

Setting range:

Standard:

Caretaker  
Facilities manager, quality manager  
Machine operator  
Bookkeeper  
Bookkeeper reduced

---

Shows information about the installed versions of the machine software.

---

No setting possible

---

–

Versions	
Name	Version
Touch panel software	SOUL_5.24.7.a39d44b_Sim (Created: 2024-03-27 16:19)
Power section software	0.0
Database version	2116
BSP version	N/A
MAC address	02:50:41:00:00:01
Qt version	5.6.3
SQLite version	3.8.10.2
Software SCA3	Copyright 2017 Schaeferer Ltd., Switzerland. All rights reserved.
Show Licensing Information	<a href="#">Show license information</a>
Export Licensing Information	<a href="#">Export license information to USB</a>

Figure: Versions

The following information can be obtained:

- Touch panel software version
- Power section software version
- Database version
- BSP accounting system version
- Mac address version
- Qt (source code) version
- Qt licence version
- SQLite version
- Copyright SCS software

Setting > Info – Machine counter	
	
Authorised profiles:	Caretaker Facilities manager
Function:	Shows an overview of beverage counters according to the ingredient they contain.
Setting range:	No setting possible
Standard:	–

Machine counters	
12.38 09 08 2024	
** Caretaker **	
Beverage	Total
Total coffee beverages	10
Total milk beverages	3
Total powder beverages	1
Total sirup beverages	0
Total hot water	4
Total steam	2

Figure: Machine counter

Example of ingredients with a chociatto beverage:

- 1. Ingredient = coffee
- 2. Ingredient = fresh milk with topping
- 3. Ingredient = choco

The following information can be obtained:

- Total coffee beverages
- Total milk beverages
- Total powder beverages
- Total hot water
- Total steam

All beverages added on the menu cards are listed.

Setting > Info – Beverage statistics	
	
Authorised profiles:	Caretaker Facilities manager Bookkeeper Bookkeeper reduced
Function:	Shows information about the dispensed beverages.



### Setting > Info – Beverage statistics

Setting range:	Reset of single or total counter readings
Standard:	Custom

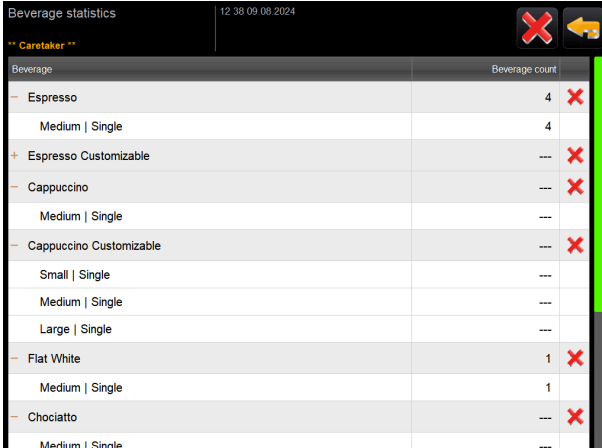

Beverage	Beverage count
Espresso	4
Medium   Single	4
Espresso Customizable	---
Cappuccino	---
Medium   Single	---
Cappuccino Customizable	---
Small   Single	---
Medium   Single	---
Large   Single	---
Flat White	1
Medium   Single	1
Chocciatto	---
Medium   Single	---

Figure: Beverage counter

## Resetting single counters

- ▶ Tap on the  button for the corresponding beverage in the right column.
  - ✓ The beverage counter for the selected beverage is set to zero.

## Resetting all counters

- ▶ Tap on the large  button at the top of the screen.
  - ✓ All listed beverage counters are reset to zero.



### Setting > Info – Cleaning statistics

Authorised profiles:	Caretaker Facilities manager Quality manager
Function:	Shows information about performed cleaning work.
Setting range:	No setting possible
Standard:	-

Date / time	Profile	System	Event
25.06.2024 13:10	Operator	Plug&Clean system	Done
24.06.2024 09:40	Service technician	Coffee system	Done
24.06.2024 09:17	Service technician	Steam boiler rinsing	Reset aborted
24.06.2024 09:17	Service technician	Coffee system	Reset timestamps
24.06.2024 09:17	Service technician	Steam boiler rinsing	Reset timestamps
24.06.2024 09:17	Service technician	Plug&Clean system	Reset timestamps
24.06.2024 09:17	Service technician	Powder system	Reset timestamps
24.06.2024 09:17	Service technician	Milk system	Reset timestamps
21.06.2024 17:43	Service technician	Powder system	Reset aborted
21.06.2024 17:42	Service technician	Coffee system	Reset timestamps
21.06.2024 17:42	Service technician	Steam boiler rinsing	Reset timestamps
21.06.2024 17:42	Service technician	Milk system	Reset timestamps

Figure: Cleaning statistics

The following information can be obtained:

- Date and time
- Profile
- System
- Event

Performed, cancelled and reset cleaning operations are displayed in the **Event** column.

### Setting > Info – Maintenance statistics

Authorised profiles:	Caretaker
Function:	Shows information about performed maintenance (descaling).
Setting range:	No setting possible
Standard:	–

Date / time	Profile	Maintenance intervals	Event
18.06.2024 07:22	Service technician	Descaling	Reset counters
07.06.2024 13:06	Service technician	Descaling	Reset counters
07.06.2024 10:49	Service technician	Descaling	Reset aborted
06.06.2024 11:53	Service technician	Descaling	Reset aborted
06.06.2024 11:53	Service technician	Descaling	Reset counters
06.11.2020 15:03	Developer	Descaling	Reset counters

Figure: Maintenance statistics

The following information is listed:

- Date and time
- Profile

- System
- Event

Performed, cancelled and reset descaling processes are displayed in the **Event** column.



### Setting > Info – Beverage dispensing statistics

Authorised profiles:	Caretaker Facilities manager Bookkeeper Bookkeeper reduced
Function:	Shows information on all beverage dispensed with the contained beverage data.
Setting range:	The  button deletes all counter levels.
Standard:	–

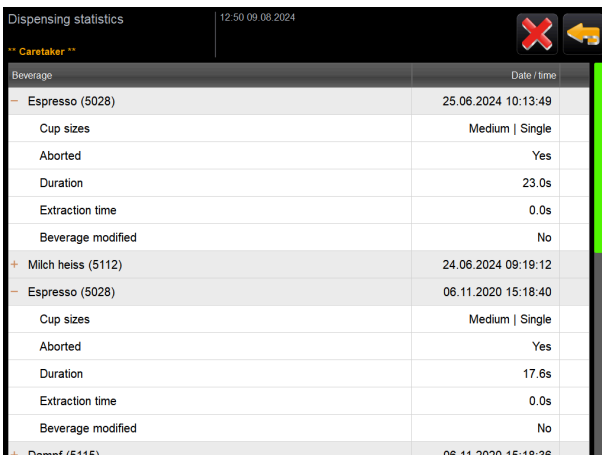

Beverage	Date / time
Espresso (5028)	25.06.2024 10:13:49
Cup sizes      Medium   Single	
Aborted	Yes
Duration	23.0s
Extraction time	0.0s
Beverage modified	No
Milch heiss (5112)	24.06.2024 09:19:12
Espresso (5028)	06.11.2020 15:18:40
Cup sizes      Medium   Single	
Aborted	Yes
Duration	17.6s
Extraction time	0.0s
Beverage modified	No
Dampf (5115)	06.11.2020 15:18:36

Figure: Dispensing statistics

The following information can be read for each type of beverage:

- Cup sizes
- Cancelled dispensing
- Dispensing duration
- Extraction time
- Beverage modified

In the **Date/Time** column, the date on which the beverage was dispensed is entered, including the time. The values, such as the cup size, for the various beverage options dispensed are also listed.



### Setting > Info – Water hardness statistics

Authorised profiles:	Caretaker
Function:	Shows information about the water hardness settings made to date.



### Setting > Info – Water hardness statistics

---

Setting range:

No setting possible

---

Standard:

–

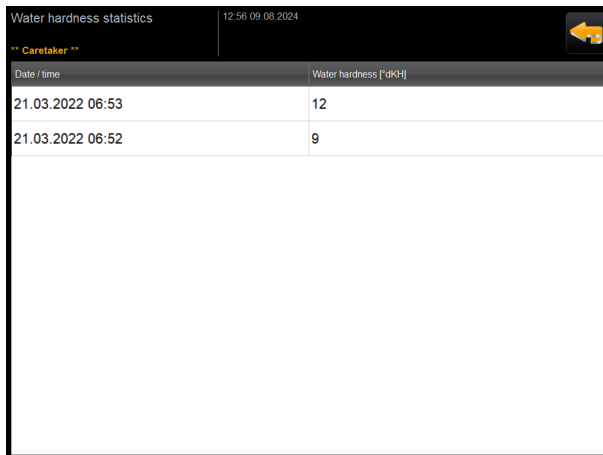

Date / time	Water hardness [°dKH]
21.03.2022 06:53	12
21.03.2022 06:52	9

Figure: Water hardness statistics

The following information can be obtained:

- Date and time
- Water hardness

The list includes a new entry for each adjustment made to the water hardness.



### Settings > Info – Machine accounting statistics

---

Authorised profiles:

Caretaker  
Bookkeeper  
Bookkeeper reduced

---

Function:

Provides information on the number of beverages dispensed with or without a sale and the total of these beverage prices.

---

Setting range:

Since last reset/Since initialisation

---

Standard:

–

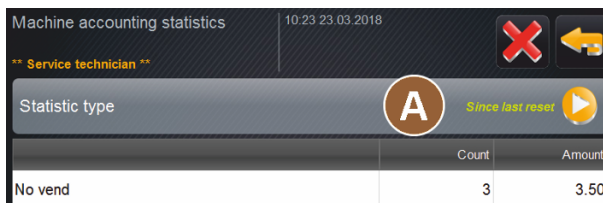



Statistic type	Count	Amount
No vend	3	3.50

Figure: Machine accounting statistics

### Since last reset

The **Since last reset** statistics can be deleted. This makes it possible to allow counters to run for a specific time.

1. Confirm that the selection list **(A)** with the  button.
2. Select the **Since last reset** statistics.
3. Tap on .
  - ✓ An instruction prompting you to confirm appears.
4. Confirm with .
  - ✓ The **Since last reset** statistics are deleted.

### Since initialisation

The statistics with the **Since initialisation** setting cannot be deleted. **Initialisation** means **since commissioning**.



#### Settings > Info – Beverage accounting statistics

---

Authorised profiles: Caretaker  
Bookkeeper  
Bookkeeper reduced

---

Function: Provides information about all dispensed beverages, their configuration, the number of beverages and their price.  
Depending on the default setting, the user statistics show the entries **Since the last reset** or as complete statistics **Since initialisation** (commissioning).

---

Setting range: Since last reset/Since initialisation

---

Standard: –

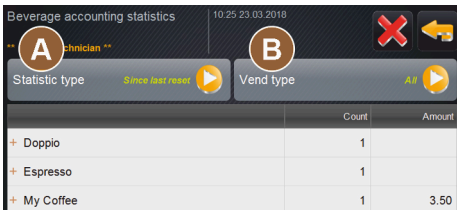

	Count	Amount
+ Doppio	1	
+ Espresso	1	
+ My Coffee	1	3.50



Figure: Beverage accounting statistics

The following sales types are available:

- All
- No vend (all beverages are listed without payment)

### Since last reset

The **Since last reset** statistics can be deleted. This makes it possible to allow counters to run for a specific time.

1. Confirm that the selection list **(A)** with the  button.
2. Select the desired statistic and the sales type.
3. Select the **Since last reset** statistics.
  - ✓ The selected statistic with sales type appears.
4. Tap on .
  - ✓ An instruction prompting you to confirm appears.



5. Confirm with .
- ✓ The **Since last reset** statistics are deleted.

#### **Since initialisation**

The statistics with the **Since initialisation** setting cannot be deleted. **Initialisation** means **since commissioning**.

### **11.4.5 Saving changes and loading them into the machine**

To save and load changes to the settings:

1. Save the selection with .
2. Exit the parameter and the setting with .
3. Load the changes to the setting/parameter into the machine with .
- ✓ The machine restarts.

## 12 Troubleshooting

A distinction can be made between the following error messages:

- Display via the functional lighting
- Messages in display

### 12.1 Meaning of the functional lighting

The machine is equipped with functional lighting as standard. In addition to messages on the display, error messages are indicated by illuminated LED colour strips on the machine.

The different colours have the following meanings:

- **White:** The machine is ready for use.
- **Orange:** Immediate action is required (e.g. refilling, cleaning).
- **Red:** Machine error (e.g. milk empty, grinding mechanism blocked, water flow error)

### 12.2 Messages in display

A distinction can be made between the following messages on the display:

- Simple error message
- Specific error message
- Error message in the Service menu

#### Simple error message

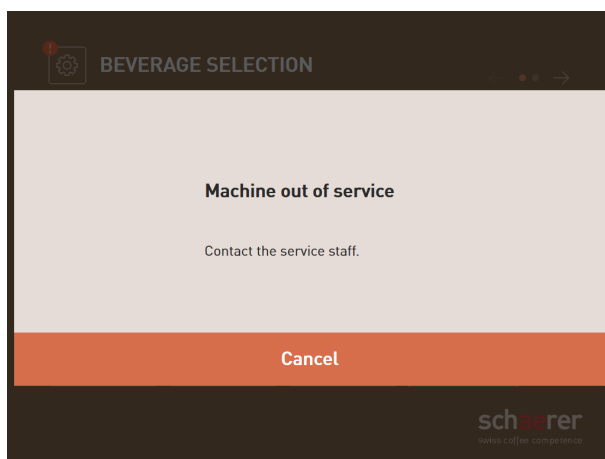

Figure: Simple error message

Prerequisite:

- **Simple error message** is activated in the user interface for **Display notification mode**.
  - ✓ In the event of an error message, the machine remains out of operation until the service staff acknowledges the message.
  - ✓ The **Inform service staff** instruction is displayed.
  - ✓ The error message cannot be acknowledged.
- Inform the service staffs.

### Specific error message

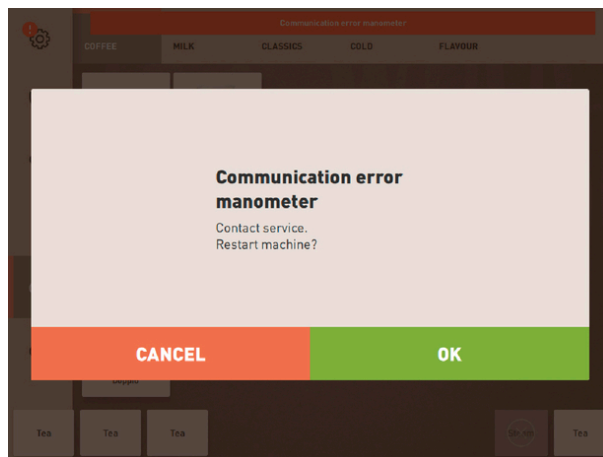

Figure: Specific error message

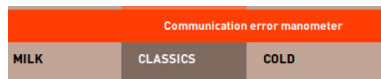

Figure: Specific error message

Prerequisite: **Specific error message** is activated in the user interface for **Display notification mode**.

- ✓ In the event of an error message, the machine is briefly out of operation.
  - ✓ **Restart** or **Inform service technician** instruction appears.
  - ✓ Error messages can be partially acknowledged.
1. Depending on the type of error, carry out one of the following actions:
  2. a) Follow the instruction for action and acknowledge the error message.
  3. b) Tap **OK** for a restart.
    - ✓ The pending error is acknowledged or the machine restarts.
    - ✓ The machine is ready for use again.
  4. If the error message cannot be acknowledged, inform the service technician.

### Error message in the Service menu

In addition to the error messages in the user interface, the error messages are displayed in the Service menu.

#### Service menu button

The **Service menu** is opened with the Service menu button.

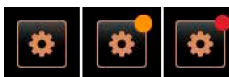

Figure: **Service menu** button with messages

In the user interface, the **Service menu** button provides information about pending information or error messages:

- **Without colour code:** There are no messages in the Service menu.
- **Orange:** There is information in the Service menu.
- **Red:** There are error messages or action requests in the Service menu.

#### Service menu screen

1. Tap on the **Service menu** button.

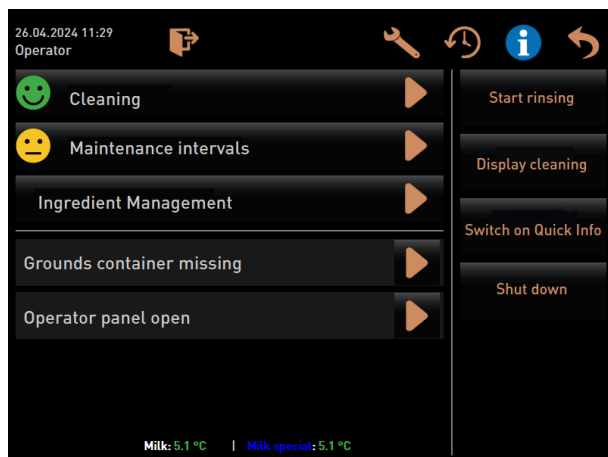

Figure: **Service menu** screen with error message

- ✓ The Service menu opens and all pending error messages are listed.
- 2. Open the error message with the ▶ button.
- 3. Carry out the displayed instruction for action and acknowledge any errors with **OK**.
- 4. If the error message cannot be acknowledged, inform the service technician.

## 12.3 Faults with display messages

For faults with a display message, a distinction is made according to the following categories:

- Malfunction
- Error
- Instruction
- Note

### 12.3.1 “Malfunction” display message

■ The following display messages have a red background in the PC board.

Display message	Cause	What to do
Milk empty	There is no milk in the milk container or the level is too low.	<ol style="list-style-type: none"> <li>1. Fill the milk container immediately.</li> <li>2. Remove the container for fresh milk.</li> <li>3. Clean the container thoroughly.</li> <li>4. Fill the container with fresh pre-cooled milk <math>\pm 5^{\circ}\text{C}</math> (<math>41^{\circ}\text{F}</math>) and put it back into the machine.</li> </ol>
Flavour Point (syrup system) 1 – 4 empty	The syrup level in bottles 1 – 4 is empty or too low.	<ol style="list-style-type: none"> <li>1. Start the <b>Flavour 1 – 4</b> process in the Service menu.</li> <li>2. Carry out the steps shown on the display.</li> <li>3. Remove and clean the hose.</li> <li>4. Reconnect the hose and activate the syrup pump with the <b>Start pump</b> button.</li> </ol>

Display message	Cause	What to do
Grounds container full	The grounds container contains about 60 – 70 coffee cakes.	<ol style="list-style-type: none"> <li>1. Empty the grounds container.</li> <li>2. Rinse out the grounds container and wipe it dry.</li> <li>3. Reinsert the grounds container.</li> </ol>
Insert grounds container	The grounds container is missing.	▶ Correctly reinsert the grounds container into the cooling unit.
	The grounds container was not completely inserted into the machine.	▶ Correctly reinsert the grounds container into the cooling unit.
Refill external drinking water tank (option)	The filling level of the external drinking water tank (option) is too low.	<ol style="list-style-type: none"> <li>1. Remove the fill level sensor from the drinking water tank.</li> <li>2. Rinse out the drinking water tank with clean water and fill it.</li> <li>3. Reinsert the fill level sensor.</li> </ol>
Empty waste water tank (option)	The filling quantity of the external waste water tank has been reached.	<ol style="list-style-type: none"> <li>1. Remove the fill level sensor from the waste water tank.</li> <li>2. Remove the waste water tank.</li> <li>3. Rinse out the waste water tank.</li> <li>4. Reinsert the fill level sensor.</li> </ol>
Centre grinder (standard), right grinder (option) overloaded or blocked	An excessive current value (> 8 A) was measured over a defined period of time. The machine tries to restart grinding five times, then the <b>Left or right grinder overloaded</b> message appears. If a beverage is requested again in this state and the problems persist, the message changes to <b>Grinder centre or right / blocked</b> . Beverage dispensing is disabled.	<ol style="list-style-type: none"> <li>1. Switch off the machine.</li> <li>2. Check the grinder for blockages and remove any foreign objects.</li> <li>3. Restart the machine.</li> <li>4. If the error appears again, the malfunction has not been resolved: Contact your service partner.</li> </ol>
Top up beans (centre grinder empty)	The centre bean hopper is empty.	▶ Refill beans.
Top up beans (right grinder empty)	The right bean hopper is empty.	▶ Refill beans.
Fill ground coffee in manual inlet	Do not insert ground coffee into the manual inlet.	<ol style="list-style-type: none"> <li>1. Open the cover of the manual inlet in the centre bean hopper.</li> <li>2. Refill ground coffee.</li> <li>3. Close the cover of the manual inlet.</li> </ol>
Fill choco or milk powder in the 1st container (1st powder container empty)	The first powder container is empty.	▶ Fill the first powder container.
Fill choco or milk powder in the 2nd container (2nd powder container empty)	The second powder container is empty.	▶ Fill the second powder container.

Display message	Cause	What to do
Tea or coffee hot water boiler excess temperature	The water supply has been interrupted.	▶ Check the level of the external/internal drinking water tank (option) and the condition of the mains water supply.
	The machine has overheated.	▶ Disconnect machine from the mains and let it cool off.
	The SSR is defective.	▶ Contact your service partner if the malfunction persists.
	The excess temperature switch has triggered.	
Steam boiler excess temperature	The water supply has been interrupted.	▶ Check the level of the external/internal drinking water tank (option) and the condition of the mains water supply.
	The steam system is clogged.	▶ Check and clean the beverage outlet and the steam system.
	The machine has overheated.	▶ Disconnect machine from the mains and let it cool off.
	The SSR is defective.	▶ Contact your service partner.
	The excess temperature switch has triggered.	
Hot water temperature too low, steam boiler temperature too low	The heating up phase is still running.	▶ Wait until the machine has heated up.
	There is an error when heating up.	1. Disconnect the machine from the mains. 2. Reconnect and switch on.
HW boiler heating time-out, steam boiler heating time-out	Although the heater is switched on, the set temperature was not reached within 5 min.	▶ Contact your service partner if the malfunction persists.
NTC hot water boiler short-circuited, NTC steam boiler short-circuited	The main board does not detect resistance. A maximum temperature (approx. 150 °C or 302 °F) is measured. Beverage dispensing is disabled.	▶ Contact your service partner if the malfunction persists.
NTC hot water boiler interrupted, NTC steam boiler interrupted	The temperature sensor has been interrupted. A minimum temperature is measured.	▶ Contact your service partner if the malfunction persists.
Brewing unit overcurrent	An overcurrent was detected on the brewing unit motor.	▶ Contact your service partner if the malfunction persists.
Brewing unit standby current	Even when the brewing unit is not in operation, it must consume a minimal amount of current. If it does not, there is an error. This may be due to the brewing unit, the power board or the wiring.	1. Check the brewing unit for blockages. 2. Contact your service partner if the malfunction persists.

Display message	Cause	What to do
Insert decalcification cartridge	Descaling agent required for the descaling process is missing.	<ol style="list-style-type: none"> <li>1. Insert the decalcification cartridge.</li> <li>2. Remove the cartridge after descaling and when an instruction appears on the display.</li> </ol>
Brewing unit time-out	<p>The brewing unit does not have a press switch for the home position. The position of the brewing cylinder is detected by measuring the current value. The following peak values are detected: Upper and lower position.</p> <p>The following time-out is defined: If no current peak is detected within 10 s of the brewing unit being moved, <b>Brewing unit time-out</b> is displayed.</p>	<p>▶ Contact your service partner if the malfunction persists.</p>
Water flow error	While a coffee product is being dispensed, the flow meter performs fewer than the defined number of minimum rotations. It is likely there is a total or partial blockage somewhere in the water system.	<ol style="list-style-type: none"> <li>1. Check the level of the drinking water tank and the condition of the mains water supply.</li> <li>2. Check the internal or external drinking water tank. (Saturation of the filter reduces the water flow.)</li> <li>3. Check whether the upper plunger is blocked or partially congested.</li> <li>4. Check the grinding level. If the grinding setting is too fine, this can inhibit or completely block the water flow.</li> <li>5. Contact your service partner if the malfunction persists.</li> </ol>
Steam supply error	The level sensor detected a low level in the steam boiler. An attempt was made to fill the boiler. However, no water was detected by the level probe within 60 s. Filling is aborted. The dispensing of beverages that require steam is disabled.	<p>▶ Contact your service partner if the malfunction persists.</p>
Modbus BP processing error	Communication error between power section and touch screen	<p>▶ Contact your service partner if the malfunction persists.</p>
Modbus MV processing error	Communication error between manometer and touch screen	<p>▶ Contact your service partner if the malfunction persists.</p>
Modbus MR processing error	Communication error between cooling unit and touch screen	<ol style="list-style-type: none"> <li>1. Check the wiring of the cooling unit and machine.</li> <li>2. Contact your service partner if the malfunction persists.</li> </ol>
Payment system error	Communication error between payment system and touch screen	<ol style="list-style-type: none"> <li>1. Restart the machine.</li> <li>2. Contact your service partner if the malfunction persists.</li> </ol>

Display message	Cause	What to do
Machine out of service	Setting in Self-service mode if no beverages can be dispensed for various reasons.	<ol style="list-style-type: none"> <li>1. Set the <b>Configuration – Timer operation</b> parameter setting accordingly.</li> <li>2. Check products such as coffee beans, milk, choco powder or milk powder.</li> <li>3. Check the temperature sensor in the cooling unit.</li> <li>4. Carry out the pending cleaning or descaling process.</li> <li>5. Contact your service partner if the malfunction persists.</li> </ol>
Communication error (various types)	Communication error between software and various modules, such as the HCU power section, Flavour Point, brewing unit, manometer, etc.	<ol style="list-style-type: none"> <li>1. Restart the machine.</li> <li>2. Contact your service partner if the malfunction persists.</li> </ol>

### 12.3.2 “Fault” display message

■ The following display messages have a yellow background in the PC board.

Display message	Cause	What to do
Brewing unit encoder error	The brewing unit motor encoder was not detected during machine initialisation.	<ol style="list-style-type: none"> <li>1. Restart the machine.</li> <li>2. Contact your service partner if the error persists.</li> </ol>
Error during automatic grinding level correction in the centre, left or right	The motor of the automatic grinding level adjustment function is running incorrectly.	<ol style="list-style-type: none"> <li>1. Cancel the grinding level setting.</li> <li>2. Restart the machine.</li> <li>3. Contact your service partner if the error persists.</li> </ol>
Machine configuration error	There is a discrepancy between the software and machine hardware.	<ol style="list-style-type: none"> <li>1. Restart the hardware detection.</li> <li>2. Restart the machine.</li> <li>3. Contact your service partner if the error persists.</li> </ol>
Steam wand temperature sensor interruption	The temperature sensor of the steam wand is not closed.	<ol style="list-style-type: none"> <li>1. Restart the machine.</li> <li>2. Contact your service partner if the error persists.</li> </ol>
Steam wand temperature sensor short circuit	The temperature sensor of the steam wand is defective.	<ol style="list-style-type: none"> <li>1. Restart the machine.</li> <li>2. Contact your service partner if the error persists.</li> </ol>
Resetting cleaning/descaling	A cleaning/descaling operation was aborted/not completed.	<ol style="list-style-type: none"> <li>1. Carry out cleaning/descaling in the Service menu.</li> <li>2. Acknowledge cleaning/descaling in the Service menu.</li> </ol>

Display message	Cause	What to do
Milk level low	The fill level in the milk container is too low.	<ol style="list-style-type: none"> <li>1. Remove the milk container.</li> <li>2. Clean the milk container thoroughly.</li> <li>3. Fill the milk container with fresh pre-cooled milk (3 – 5 °C or 37.4 – 41 °F) and put it back into the machine.</li> </ol>
Grounds container full soon	The grounds container will soon contain about 60 – 70 coffee cakes.	▶ Empty the grounds container when convenient.
Closing user panel	The user panel is open or was not completely closed.	▶ Push the user panel downwards until it snaps into place.
External drinking water nearly empty (option)	The fill level of the external drinking water tank (option) is too low.	▶ Empty the drinking water when convenient.

### 12.3.3 “Instruction” display message

The following display messages are stored in white in the control system.

Display message	Cause	What to do
Insert grounds container	The grounds container is missing or was not completely inserted into the machine.	▶ Correctly reinsert the grounds container into the cooling unit.
Close user panel	The user panel is open or was not completely closed.	▶ Push the user panel downwards until it snaps into place.
Refill external drinking water tank (option)	The fill level of the external drinking water tank is too low.	<ol style="list-style-type: none"> <li>1. Remove the fill level monitoring unit from the external drinking water tank.</li> <li>2. Rinse out the external drinking water tank with fresh water and fill it.</li> <li>3. Reinsert the fill level monitoring unit.</li> </ol>
Empty waste water tank (option)	The filling quantity of the external waste water tank has been reached.	<ol style="list-style-type: none"> <li>1. Remove the fill level monitoring unit from the external waste water tank.</li> <li>2. Rinse out the external waste water tank with fresh water and fill it.</li> <li>3. Reinsert the fill level monitoring unit.</li> </ol>
Top up beans (centre grinder empty)	The centre bean hopper is empty.	▶ Fill the bean hopper.
Top up beans (right grinder empty)	The right bean hopper is empty.	▶ Fill the bean hopper.
Fill ground coffee in manual inlet	Do not insert ground coffee into the manual inlet.	<ol style="list-style-type: none"> <li>1. Open the manual inlet in the centre bean hopper.</li> <li>2. Refill ground coffee.</li> <li>3. Close the manual inlet.</li> </ol>
Fill choco or milk powder in the 1st container (1st powder container empty)	The 1st powder container is empty.	▶ Refill the first powder container.

Display message	Cause	What to do
Insert decalcification cartridge	The descaling process requires the descaling agent from the decalcification cartridge.	<ol style="list-style-type: none"> <li>1. Insert the decalcification cartridge.</li> <li>2. Remove the decalcification cartridge after descaling and when an instruction appears on the display.</li> </ol>

### 12.3.4 “Note” display message

■ The following display messages have a blue background in the PC board.

Display message	Cause	What to do
Caution: A blocked waste water outlet can cause flooding.	There are left-over coffee grounds in the waste water.	▶ Check the waste water outlet and the drip tray for blockages and clean them.
Wait until the payment system is fully initialised.	Initialisation is running.	▶ Wait until initialisation of the payment system is complete.
Wait until telemetry connection is established or contact service.	The <b>Coffee Link</b> display is overdue.	<ol style="list-style-type: none"> <li>1. Restart the telemetry.</li> <li>2. Contact your service partner if the malfunction persists.</li> </ol>

Malfunction	Cause	What to do
The display is dark.	The machine is not connected to the mains.	<ol style="list-style-type: none"> <li>1. Connect the machine to the mains.</li> <li>2. Contact your service partner if the malfunction persists.</li> </ol>
	The machine is not switched on.	<ol style="list-style-type: none"> <li>1. Switch on the machine.</li> <li>2. Contact your service partner if the malfunction persists.</li> </ol>
No beverages with milk are available.	The milk container is empty.	<ol style="list-style-type: none"> <li>1. Fill the milk container.</li> <li>2. Contact your service partner if the malfunction persists.</li> </ol>
	The milk system is clogged.	<ol style="list-style-type: none"> <li>1. Perform daily cleaning.</li> <li>2. Contact your service partner if the malfunction persists.</li> </ol>
	The milk system was disabled by mistake.	<ol style="list-style-type: none"> <li>1. Check the cable connection from the machine control cable to the cooling unit.</li> <li>2. Activate the milk system.</li> <li>3. Contact your service partner if the malfunction persists.</li> </ol>

Malfunction	Cause	What to do
No beverages with milk foam are available.	The milk container is empty.	<ol style="list-style-type: none"> <li>1. Fill the milk container.</li> <li>2. Contact your service partner if the malfunction persists.</li> </ol>
	The milk system is clogged.	<ol style="list-style-type: none"> <li>1. Perform daily cleaning.</li> <li>2. Contact your service partner if the malfunction persists.</li> </ol>
	The milk system was disabled by mistake.	<ol style="list-style-type: none"> <li>1. Check the cable connection from the machine control cable to the cooling unit.</li> <li>2. Activate milk system.</li> <li>3. Perform daily cleaning.</li> <li>4. Contact your service partner if the malfunction persists.</li> </ol>
No beverages with syrup (Flavour Point) are available.	The syrup bottle is empty.	<ol style="list-style-type: none"> <li>1. Fill the syrup bottle.</li> <li>2. Contact your service partner if the malfunction persists.</li> </ol>
	The Flavour Point system is clogged.	<ol style="list-style-type: none"> <li>1. Perform daily cleaning.</li> <li>2. Contact your service partner if the malfunction persists.</li> </ol>
	The Flavour Point system has been incorrectly disabled.	<ol style="list-style-type: none"> <li>1. Check the cable connection from the machine control cable to the Flavour Point.</li> <li>2. Perform daily cleaning.</li> <li>3. Contact your service partner if the malfunction persists.</li> </ol>

## 13 Disassembly

After end of service life

After the machine has reached the end of its service life:

1. Disassemble the machine.
2. Dispose of the machine in an environmentally-friendly manner.

## 14 Disposal



The machine must be disposed of properly in accordance with local and legal regulations.

- ▶ Contact your service partner for this purpose.

If no return or disposal agreement has been made, disassembled components must be recycled.

1. Scrap metal parts.
2. Recycle plastic elements.
3. Dispose of the remaining components after sorting them according to material properties.
4. Dispose of operating materials and cleaning products in line with local regulations and the respective manufacturer instructions.